

ED 025 495

24

SP 002 146

By- Southworth, Horton C.

A Model of Teacher Training for the Individualization of Instruction; Educational Specifications for a Comprehensive Undergraduate and Inservice Teacher Education Program for Elementary Teachers. Final Report.

Pittsburgh Univ., Pa. School of Education.

Spons Agency- Office of Education (DHEW), Washington, D.C. Bureau of Research.

Bureau No- BR-8-9020

Pub Date 31 Oct 68

Contract- OEC-0-8-089020-3309(010)

Note- 210p.

EDRS Price MF-\$1.00 HC-\$10.60

Descriptors- Academic Education, Admission Criteria, Behavioral Objectives, Educational Diagnosis, *Educational Specifications, *Elementary School Teachers, Evaluation, Field Experience Programs, Guidance, *Individualized Instruction, Individualized Programs, Mathematics Curriculum, *Models, Professional Education, Program Evaluation, Program Planning, Science Curriculum, Task Analysis, *Teacher Education Curriculum, Teacher Selection

The Model of Teacher Training for the Individualization of Instruction, developed at the University of Pittsburgh, is predicated upon five requirements for training teachers: (1) academic education, (2) professional education, (3) competencies, (4) guidance, and (5) clinical setting. Instruction is individualized (tailored to suit the characteristics of individual learners) and implemented through the instructional mode (a basic plan to restructure all teacher-learner experiences to include specifying goals, assessing student achievement, diagnosing learner characteristics, planning programs with students, guiding students, and evaluating student progress). Points of entry into the program differ, depending on an individual's prior training and experience. Guidance permits varied coursework and varied rate of completion of the necessary 32 learning units. In the clinical setting, guidance procedures call for extending individualization beyond the learning of concepts and skills into the development of competencies in self-direction, inquiry, and personal-social characteristics. (Appended are a 26-item bibliography and descriptions of task, or competency, analysis; directing off-task pupil behavior; and mathematics and science modules. ED 018 677 summarizes the nine models.) (Author/SG)

U.S. DEPARTMENT OF HEALTH, EDUCATION & WELFARE
OFFICE OF EDUCATION

THIS DOCUMENT HAS BEEN REPRODUCED EXACTLY AS RECEIVED FROM THE
PERSON OR ORGANIZATION ORIGINATING IT. POINTS OF VIEW OR OPINIONS
STATED DO NOT NECESSARILY REPRESENT OFFICIAL OFFICE OF EDUCATION
POSITION OR POLICY.

Final Report

Contract No. O-8-089020-3309(010)

A MODEL OF TEACHER TRAINING FOR
THE INDIVIDUALIZATION OF INSTRUCTION
Educational Specifications for a Comprehensive
Undergraduate and Inservice Teacher Education
Program for Elementary Teachers

Directed by

Horton C. Southworth, Chairman

Elementary Programs
School of Education
University of Pittsburgh

Pittsburgh, Pennsylvania

October 31, 1968

The research reported herein was performed pursuant to a contract
with the Office of Education, U. S. Department of Health, Education,
and Welfare. Contractors undertaking such projects under Government
sponsorship are encouraged to express freely their professional judg-
ment in the conduct of the project. Points of view or opinions stated
do not, therefore, necessarily represent official Office of Education
position or policy.

U.S. DEPARTMENT OF
HEALTH, EDUCATION, AND WELFARE

Office of Education
Bureau of Research

ED025495

SP002146

PREFACE

In recent years there has been a re-emergence of serious attempts to examine the requirements for individualizing education in the elementary school in practical and operational ways. The School of Education at the University of Pittsburgh has been particularly sensitive to these developments and has participated in the research and development aspects of both the Project of Individually Prescribed Instruction and Project Plan.

To a very considerable extent the School of Education's sensitivity has been generated and maintained by faculty members in elementary education and in other departments who have worked with staff members of the Learning Research and Development Center on the University campus in a variety of projects. Several hold joint appointments in the Center and the School of Education. Dr. Horton Southworth, who prepared both the initial proposal and this final report, has acknowledged the significant assistance and consultation of many colleagues in a statement of appreciation in another section of this document. I would like to join him in that acknowledgement, mentioning particularly Dr. Robert Glaser, Dr. John Bolvin, and Dr. Glen Heathers of the Learning Research and Development Center, all of whom also hold faculty appointments in the School of Education.

Arising from the above mentioned concern, the School of Education has become most interested in the changing requirements of university teacher education for adapting to the new educational models for individualizing instruction. In particular, the faculty in elementary education has given careful attention to teacher education requirements for individualization.

This trend in teacher education can lead to important developments in adapting elementary and secondary schools to community problems and in redesigning the schools in the metropolitan city. Perhaps the greatest impact, however, of individualizing teacher preparation could be the improved achievement of elementary school students so that major re-alignments would be necessitated in the curricula of secondary schools and of higher education.

This report is a tangible outcome of the cooperative endeavor of many individuals as interpreted and expressed by Dr. Southworth. It could be the first framework of specifications solid enough to support the individualization of teacher education. The faculty in

elementary education at the University of Pittsburgh looks forward to testing the possibility, and all of us in the School of Education expect to do what we can to encourage and support that effort.

We anticipate with both hope and confidence the professional adventure of implementing through these specifications the individualization concepts which have already shown such promise with elementary and secondary school children.

Paul H. Masoner, Dean
School of Education
University of Pittsburgh

ACKNOWLEDGEMENTS

1. Final responsibility for the components of the model is assumed by Horton C. Southworth, Chairman, Elementary Programs and Director of the model project. All questions should be directed to him.
2. To remain consistent with the philosophy of individualization, which is that of change, any set or ordering of these model components must be considered open-ended. This allows for specific refinements and current adaptations by the implementor of the model.
3. The Director especially wishes to give credit to the design team that generated the model: Dr. John Bolvin, Associate Director, Learning Research & Development Center, Mr. Nicholas DeFigio, Lecturer in Education, Dr. Charles Gorman, Assistant Professor of Education, Dr. Glen Heathers, Professor of Education, and Dr. James D. Hoffman, Professor of Education. The team was assisted over approximately eight months of study and component development by numerous faculty, staff and consultants who are listed in the appendix.

TABLE OF CONTENTS

	<u>Page</u>
Chapter I. Introduction to the Model	2
Chapter II. Model: Requirements	7
A. Introduction	
B. Requirements for Teacher Training	9
1. Requirement 1 - Academic Knowledge.....	
2. Requirement 2 - Professional Knowledge..	12
3. Teacher Competencies	13
4. Guidance of Trainees	23
5. Clinical Settings	24
Chapter III. The Model: Procedures	27
A. Introduction	27
B. Procedures for Teacher Training	32
1. Admission into Education	32
2. Guidance Component	34
3. Course Selection	36
C. Clinical Settings for Teacher Training	39
1. Simulated Clinical Setting	40
2. Differentiated Roles	44
3. Coalition	45
D. Faculty Instructional Modes	46

TABLE OF CONTENTS

	<u>Page</u>
Chapter IV. The Model: Implementation	49
A. Introduction	49
B. Academic Education	50
1. Communication	50
2. Instructional Modes	50
C. Professional Education	52
1. Analysis Routine	52
2. Applicability of Analysis Outline	54
D. Teacher Competencies	54
E. Guidance	55
F. Clinical Setting	57
G. University Implementation	59
H. Evaluation Questions for Teacher Training Model	64
1. Implementation	65
2. Assessment	66
3. Philosophy	67
Chapter V. Summary	69
Bibliography	97
Glossary	100

TABLE OF CONTENTS

	<u>Page</u>
Appendixes	
A. Procedure for Analyzing A Task or Competency.....	104
B. Directing Off-Task Pupil Behavior.....	120
C. Mathematics Module	130
D. Science Module	141
F. Consultants to the Team.....	203

TABLE OF ILLUSTRATIONS

		<u>Page</u>
Figure No. 1	Requirements for Teacher Training	26
Figure No. 2	Requirements for Self-Development	29
Figure No. 3	Shows Interrelationship of Major Components: Expanding Knowledge Base of the Model	30
Table I	Nature of the Contributions of Each Component to Individualization	31
Figure No. 4	Admission and Exit Procedures	33
Table II	Guidance Pattern	35
Figure No. 5	The Model Sequence	36
Table III	Simulated Clinical Setting	43
Table IV	Differentiate Roles	44-45
Figure No. 6	General Instructional Mode	48
Figure No. 7	Academic Education Requirement	51
Figure No. 8	Professional Education Requirement	53
Figure No. 9	Teacher Competency Requirement	56
Figure No. 10	Guidance Requirement	58
Figure No. 11	Coalition for Implementation of Individuali- zed Instruction	60-61
Figure No. 12	University Implementation Sequence of Events .	63
Figure No. 13	Program Regeneration System	68
Figure No. 14	General Training Plan for Self-Development...	71
Figure No. 15	Sequential Progress of Trainee	72
Figure No. 16	General Teaching Mode	73

TABLE OF ILLUSTRATIONS

	<u>Page</u>
Figure No. 17 General Teaching Mode for Mathematics	74
Table V Teacher Training Requirements	76
Figure No. 18 Guidance Procedures	81
Figure No. 19 Admission Procedure	82
Figure No. 20 Total Sequential Movement of Trainee Through Program	84-85
Figure No. 21 Competency-Unit Experience	88
Figure No. 22 The Gestalt	91
Figure No. 23 Program Regeneration System	92
Figure No. 24 University Implementation	93
Figure No. 25 Procedure for Analyzing a Task or Competency.	112
Figure No. 26 General Teaching Mode for Mathematics Educa- tion.....	133-A
Figure No. 27 Schematic Representation of Mathematics for Elementary Teachers.....	135
Figure No. 28 Science Education for Elementary Teachers Learning Module.....	144
Figure No. 29 Schematic for Science Module.....	196

A MODEL FOR TEACHER TRAINING FOR INDIVIDUALIZATION OF INSTRUCTION

CHAPTER I. INTRODUCTION TO THE MODEL

This is a training model for individualized instruction. The model proposes that the teacher will be instructed by a professional faculty using the same principles and practices of individualized instruction that the teacher will subsequently use with pupils.

The model provides a comprehensive program to prepare teachers for the elementary school. The program will use individualized instruction to prepare teachers in order to facilitate the individualization of instruction within any school.

Definition

Individualized Instruction. The central theme in the elementary instructional programs for which the new model will train teachers is individualization. This term covers any arrangements and procedures that are employed to ensure that each pupil achieves the learning goals designated for him. The definition of individualization used in this model is as follows: Individualized instruction consists of planning and conducting, with each pupil, programs of study and day-to-day lessons that are tailor-made to suit his learning requirements and his characteristics as a learner. This definition focuses on instructional planning with and for each individual student before teaching him, then teaching him according to the plan. Most educators mistakenly define individualization in terms of the setting within which learning takes place, limiting it to tutorial instruction or independent study.

Group teaching can also be a part of individualized programs. Whenever two or more pupils are ready to study the same task in a like way through group presentation or discussion, it is proper for the teacher to assemble and teach them as a group. This is very different from most instruction today where plans are made for the group as a whole and where instruction pays limited attention to individual differences among pupils in the group.

Three programs of individualized instruction* currently under development satisfy the definition of individualization as a matter

*

Individually Prescribed Instruction, LRDC, University of Pittsburgh Primary Education Project, General Learning Corporation and School Project Plan, Westinghouse and AIR.

of tailor-making lessons for each pupil. These three are not the only current programs of individualized instruction.* They are used here simply to exemplify programs that satisfy the definition of individualization offered above.

The first program is Individually Prescribed Instruction (IPI) being developed by the Learning Research and Development Center at the University of Pittsburgh in cooperation with the Baldwin-Whitehall School District in suburban Pittsburgh. I.P.I. was implemented first at Oakleaf Elementary School. It currently applies to reading, spelling, mathematics, and science. Research for Better Schools, the Regional Educational Laboratory located in Philadelphia, presently is field testing the programs in nearly 100 elementary schools across the country.

A second program is the Primary Education Project (PEP) being developed by the Learning Research and Development Center, School of Education, University of Pittsburgh and General Learning Corporation in cooperation with the Pittsburgh Public Schools. This program is a meaningful model for nursery and primary school education in the inner city. It is being developed at Frick Elementary School in Pittsburgh.

The third program is Planned Learning According to Needs (Project PLAN) under development by the American Institutes for Research in Palo Alto, California. This program is being developed for grades 1-12 in the areas of language arts or English, social studies, mathematics, and science. Twelve school systems, including the Pittsburgh, Penn-Trafford, and Bethel Park; Pennsylvania Schools currently are helping develop and test PLAN.

The following is a list of actual or intended features that these programs have in common and indicates major characteristics of those types of instructional programs for which the new teacher education model has been designed.

1. Instruction is organized in terms of programmed curricular units rather than courses, with the units in each curricular area arranged in a specified sequence.
2. On the basis of achievement pretests and the diagnosis of learner characteristics, lessons are tailor-made with each pupil rather than being planned for a group**

*

Several experimental programs in computer assisted instruction exist.

**

A bank of lessons is accumulated, of course, which can be applied to or adapted to other students of like requirements.

3. Several modes of individualization are employed, singly or in combination, in suiting instruction to the individual pupil: varying learning goals from pupil to pupil, varying learning materials and equipment, varying the learning setting (independent study, pupil team, tutoring by the teacher, small group working without the teacher, small group with the teacher, large group), varying instructional techniques, assigning different students to different teachers, and varying the rate of advancement through the curriculum.
4. Each pupil is expected to master a learning task before proceeding to the next task; mastery is determined with use of a unit posttest. The criterion score for mastery is empirically determined in relation to performance on subsequent tasks.
5. Teachers* offer pupils help chiefly on an individual basis, and are always available for consultation.
6. The pupil conducts most of his learning independently of the teacher, employing self-direction.

The following are features of some, but not all, individualized programs. Since they are important contributors to the effectiveness of individualization, and since they are apt to become increasingly used in innovative programs, the teacher education model should prepare teachers for them.

1. There are two or more achievement subtests for each curricular unit.
2. Materials and equipment are available to provide pupils with alternate routes toward mastering a given learning task.
3. Instruction is given to increase pupils' competencies in self-directed learning.
4. Pupils become responsible for prescribing their learning tasks at least part of the time.
5. Systematic use is made of reinforcement to shape and maintain pupils' behavior.

*

The term "teacher" is used to include all members of the instructional staff, including master teachers, subject consultants, teacher aides, and specialists such as librarians. The pupil is helped to learn the nature of the assistance he might best seek from each.

6. Two or more staff members and auxiliary aides team up in working with the same pupils.
7. Flexible organizational arrangements are used to facilitate individualization.
8. Computerized data systems are used for storing and retrieving information about each pupil.

Individualization, as represented by the three models mentioned above, incorporates three themes. Education for optimum achievement is provided since all three programs require all pupils to master a given learning task before proceeding the next task in the curricular sequence. Employing educational technology is a feature of each of the programs. Technological aids being used in the program include audio tapes, phonograph records, data storage, and computer assisted instruction. Differentiated staff roles and team patterns are represented in the programs. IPI uses teacher teamwork, while PLAN employs some teacher specialization and teamwork in the upper elementary grades.

Individualized programs depend greatly on the use of carefully-programmed learning materials that specify, step-by-step, what the pupil is to do and give prompt feedback information on the correctness of responses. The learning goals that have been demonstrated to be achieved effectively through programmed materials of this sort include tool skills, concepts, principles, and facts. Access to an array of aids, materials, and instructional alternatives is essential for each pupil and teacher.

In summary this model is intended to provide for all aspects of the post high school education of elementary teachers. It is meant to accommodate all persons seeking initial or continuing teacher education regardless of the roles they will fill in elementary schools and regardless of their individual training needs.

1. The model will cover teacher education from nursery through middle-school.
2. The model will prepare teachers to individualize instruction according to the requirements detailed in Chapter Two.
3. The model calls for full individualization of the teacher education program according to the same set of requirements.
4. The same basic model is to be employed with pre-service and in-service teacher education. Points of entry into the program will differ dependent on prior training and

experience. Teacher educators must employ the same model to "learn about" individualization and to complete it.

5. The model will allow for students entering the pre-service program out of different prior situations and at different ages.
6. The model will provide preparation for various roles in elementary schools - specialists teachers, educational diagnosticians, interns, and aides.
7. The model requires that the student in the program, in addition to taking the required number of liberal arts courses, exhibit mastery of special units of liberal arts work that are judged to be crucial for successful teaching in elementary school. These special units will be designed through the cooperative efforts of liberal arts and education professors and will be taught on an individualized basis.
8. The model calls for extending individualization beyond the learning of concepts and skills into the learning of competencies in self-direction and inquiry, as well as into the learning of personal-social-characteristics.

CHAPTER II. THE MODEL

THE REQUIREMENTS FOR TEACHER TRAINING

A. INTRODUCTION

The purpose and broad context for the new model of undergraduate elementary teacher training was described in the first chapter of this document. In Chapter Two, the requirements for elementary teacher training will be clarified. Five general requirements will be discussed including 1) the Liberal studies which enlighten a human being, 2) the knowledge base for establishing the profession of teaching, 3) minimal competencies prerequisite to initial certification for teaching, 4) the guidance of teacher trainee's through the program, and 5) the clinical setting for training.

The authors wish to make clear the fact that any set or ordering of competencies and delineation of knowledge areas must be considered open-ended. One of the challenges to the bidder or implementer of this model will be the need for faculty consideration of these same basic factors. The learning outcomes, the knowledge base, and the nature of the learner must be carefully studied in attempts to re-structure teacher training. Approximately eight months of study and component development are represented in the model, but its implementation would demand continued refinement of the specifications.

Focusing on the school of the future and its needs, and the child of the future and his needs, leads us to a consideration of individualized instruction. Both individual and society will need a most unique development and exercise of individual talents; the school must offer the opportunity to develop and excel in these respects. As stated by John Gardner the problem is to provide opportunities and rewards for individuals at every level of ability to realize their potentials and to perform at their best, while at the same time adjusting to society's institutional defenses against excessive emphasis on individual performance.

The Liberal Education Required in Teacher Training

Aspiring teachers, prepared in an individualized program, cannot be expected to follow a set of specifications like technicians. That is not the intent of the new psychology or the new programs for the

¹John W. Gardner, Excellence: "Can We Be Equal and Excellent Too?" Harper-Row, New York, N.Y., 1961

school of the future. Our challenge is to design programs and strategies for the academic areas so that aspiring teachers are enlightened by these experiences. Will the typical liberal arts sequence do this?

The answer lies both in the program of study and in the processing through that program. A first step would be to treat the students themselves as individuals, allowing them freedom to design parts of their own program of study. A second step would be to reform foundation courses in the liberal arts so that they would be relevant to today's world and needs. This statement is not as paradoxical as it seems, and simply means that instructors in academic areas must constantly search for methods and means to help their students see the relationships and transfers between the old and the new worlds. (The classical content is not forbidden.) Another strategy to accomplish this kind of relevancy objective is to convince instructors to teach the structures and processes of a discipline as well as content. Finally, the academic requirements must be correlated with the program requirements of the School of Education, demonstrating to students the relevancy of content, and showing them the need for a liberal base as they make decisions in elementary classrooms.

Any university implementing this proposal must examine its own liberal arts program, deciding what courses, units, or experiences they wish to retain as serving their conception of the best base for teacher education. They must also examine the competencies required for individualizing instruction, to see what courses create a segment of the knowledge base needed for that competency. We are suggesting that the liberal arts serve as a liberalizing agent, yes, but are also strongly suggesting that a chief function of this component is to give the base for the profession. A physician studies medicine to practice it. Prospective teachers of individualization study in the liberal arts to give them a view of humanity that reflects a deep humanism; so they can properly individualize instruction for children.

The educated man is defined by his culture, and oft-times the definitions are not clearly made. The education of the professional man is defined by his intended profession, not the culture. Each profession decides upon a funded content appropriate to the profession, defines the roles of the processors, chooses locations and states the time necessary for the developments that evidence professional competency.

B. REQUIREMENTS FOR TEACHER TRAINING

1. REQUIREMENT I - ACADEMIC KNOWLEDGE

Underlying each teacher competency area must be a conceptual basis, that is; Academic Knowledge that is relevant to developing and implementing the area. Some of these competencies areas are rooted in the Liberal Arts, such as: Specifying Learning Goals, and Guiding Students with their Learning Tasks.

a. Liberal Arts in the Elementary Curriculum

Since no teacher can gain command of more than a small fraction of existing knowledge even in one area, the required knowledge in the humanities, communications, natural science, mathematics, and the arts should be of the types indicated below:

Familiarity with sub-areas of knowledge covered by the field, and with general classification schema for ordering knowledge in the field.

Command of key concepts in the field.

Knowledge of key principles in the field.

Knowledge of the history and development of this field.

Knowledge of major modes of inquiry employed in gaining and applying knowledge within the field.

Familiarity with major modes of investigation for gaining access to recorded knowledge of the field.

Knowledge of interdisciplinary relationships.

Knowledge of relevant materials in the field.

b. Behavior Sciences in the Elementary Curriculum

Knowledge of the Behavioral Sciences is a requirement for understanding individual development and functioning, and group structures and processes.

All nine teacher competency areas in the following section of this chapter depend strongly on knowledge. The theoretical and methodological contributions of psychology are especially evident in the following:

Assessing Student Achievement of Learning Goals
Diagnosing Learner Characteristics
Guiding Pupils with Their Learning Tasks
Directing Off-task Pupil Behavior
Enhancing Self Development

The contributions of Anthropology are particularly relevant to understanding the environmental influence on human capacity and achievement.

The teacher should have:

Knowledge of theory and measures of human capacity.

Knowledge of motivation theory with particular attention to achievement, emotional dependency and autonomy.

Knowledge of learning theories with attention to concepts, principles, skills, problem solving.

Knowledge of personality theory with particular attention to self-concept, emotional make-up, and such dispositions as impulsivity, persistence, rigidity, and tolerance of ambiguity.

Knowledge of approaches to defining personality characteristics, observation, interviews, inventories, or tests.

Knowledge of attitude and value development, with particular reference to the influence of role models.

Knowledge of the development and functioning of informal and formal groups.

Knowledge of intergroup differences in motives, attitudes, values, and social norms, and of their influence on responses to schooling.

Knowledge of the sources and resolution of prejudice.

Knowledge of the development of interpersonal relationships in children, both toward adults and toward peers.

Knowledge of the societal and cultural forces that shape personality and ultimately capacity and performance.

c. Social Sciences in the Elementary Curriculum

Knowledge of "School in Society" is a requirement for planning and conducting instruction and for membership on a school faculty.

The teacher should have:

Knowledge of the functions of schools in American society, with special attention to the relations between education in school and out of school.

Conceptual grasp of the major types of learning goals and knowledge of how they are represented in elementary school curricula.

Knowledge of how curriculum decisions reflect the values of American society in general, of the region or community, and of different interest groups.

Knowledge of basis for decision about instructional approaches with attention to individualizing instruction relevant to characteristics of learner and community.

Knowledge of institutions which control community and the organic relationship of school and community.

Knowledge of the school as a miniature social system with positions, roles, role relationships, rules, traditions, and communication patterns.

Knowledge of new positions, roles, and status of teachers with particular attention to new patterns of specialization, teamwork of teachers, and the effects of individualized instruction and educational technology on the teacher.

Knowledge of the current "revolution in instruction" in terms of its philosophical and cultural roots; in terms of the major themes underlying new developments; and in terms of the various types of instructional innovations and their uses in the schools.

Knowledge of professional organizations in relation to ethical standards, relevant program, media, financing, and organization and evaluation.

2. REQUIREMENT 2 - EXTENDING PROFESSIONAL KNOWLEDGE BASE

The broad base for individualization is the accumulation of knowledge about current elementary curriculum, the learning process as reflected in foundations of school in society. This knowledge base is not static, and through a process of data collection, essential to the development of a definitive knowledge base for the practice of teaching are two objectives:

1. To clarify, explain, and conceptualize the decision-making process employed in teaching.
2. To establish a system for modifying the decision-making process in such a way as to incorporate knowledge about human learning.

The process, as a whole, is dedicated to bridging the communications gap between research and educational practice, school districts and faculty, faculty and trainees, trainees and pupils. Building upon the solid foundation of training practices, relationships in clinical centers, and established individualized instructional models, the process develops a procedure for realizing a clinical dimension in the teacher education setting. It is hoped that this will lead to a more direct approach in teacher education since the objectives of teacher behavior are made more visible. Three assumptions are basic to the Clinical Cycle: 1) that an explicit model of teacher behavior has more effectiveness in individualized situations than does an implicit model; 2) that a teacher decision can be analyzed explicitly; and 3) that an explicit model (or parts of an explicit model) can be changed more readily than an implicit model.

Universities implementing new models must develop alignment with research faculty, school districts, teacher organizations, government agencies and establish meaningful communication.

3. REQUIREMENT 3 - TEACHER COMPETENCIES

Minimal Teacher Competencies

A minimal competency means the ability of the teacher trainee to define and demonstrate successfully each specific task or function necessary for teacher certification.

The following nine competency areas are paramount for training teachers to individualize instruction for each child. Behaviors which are not currently within the capability of educators to observe or measure have not been included among these nine areas.

1. SPECIFYING LEARNING GOALS *

Teachers will be prepared to specify learning goals in terms of observable competencies.

The teacher can:

- 1.01 Identify learning objectives of each type, independently of any one curricular area, or within a given curricular area.
- 1.02 State learning objectives of each type within each (relevant) curricular area in terms of student behaviors.

The teacher can define:

- 1.021 Concepts, principles, facts
 - 1.022 Skills
 - 1.023 Inquiry competencies
 - 1.024 Self-direction competencies
 - 1.025 Interests, motives, and values
 - 1.026 Competencies in self-analysis and self-evaluation
 - 1.027 Personal development
 - 1.028 Group process behaviors
- 1.03 Interpret learning outcomes in terms of acceptable criteria of performance.
 - 1.04 Specify interrelationships among the various types of learning goals.

*Refer to the Appendix for a sample unit on Analyzing a Task or Competency.

- 1.05 Specify interrelationships among learning goals from one curricular area to another.
- 1.06 Translate broad societal aims for schools into relevant learning goals.
- 1.07 Communicate learning objectives to pupils, teachers, parents, and others.

2. ASSESSING PUPIL ACHIEVEMENT OF LEARNING GOALS

A detailed analysis of the initial capabilities of a learner in a curricular area provides the necessary base-line reference for the coming instruction. The teacher will be skillful in evaluating pupil accomplishments with regard to a variety of learning goals.

The teacher can:

- 2.01 Demonstrate competency in the use of rating methods, observational methods, interview methods, and situational tests in evaluating pupils' accomplishment of these types of learning goals; inquiry, self-direction, interests and motives, self-analysis and self-evaluation, personal development, cooperative behaviors, and group process.
- 2.02 Explain the relationships among placement tests, pretests, and posttests of a pupil's achievement in any curricular area.
- 2.03 Select appropriate placement tests for locating a pupil with a given curricular area.
- 2.04 Administer and score placement tests.
- 2.05 Interpret placement test results to locate pupil within a curricular area.
- 2.06 Identify a pupil's learning difficulties through analysis of test results.
- 2.07 Involve the pupil in evaluating and interpreting his test result.
- 2.08 Demonstrate competency in reporting test results to other staff members in numerical, graphic, or verbal form.

3. DIAGNOSING LEARNER CHARACTERISTICS

The state of the learner is a dynamic phenomena. Thus, teachers will need refined observational skills to recognize developing traits, synthesizing techniques to organize existing data, and supporting references to use in developing an improved appraisal of the learner.

The teacher will:

- 3.01 Appraise the intellectual capacities of the pupil.**
 - 3.011 Report a pupil's general intellectual functioning as it is observed in a variety of learning activities.**
 - 3.012 Summarize accumulated data pertaining to intellectual capacity, taking account of the pupil's background, developmental level, and reaction to testing.**
 - 3.013 Identify appropriate tests which could be used to improve the appraisal of a pupil's general intellectual capacities.**
- 3.02 Appraise the physical condition of the pupil.**
 - 3.021 Report a pupil's sensory functioning, motor development, and general health as they are observed in a variety of learning activities.**
 - 3.022 Summarize accumulated data pertaining to the pupil's sensory functioning, motor development and general health.**
 - 3.023 Identify appropriate sources which could offer additional information to improve the appraisal of a pupil's physical condition.**
- 3.03 Appraise the emotional condition of the pupil.**
 - 3.031 Report a pupil's emotional condition as observed in a variety of learning activities.**
 - 3.032 Summarize accumulated data pertaining to the pupil's emotional condition.**

- 3.033 Identify other sources and evaluative techniques which could be used to improve the appraisal of a pupil's emotional condition.
- 3.04 Appraise the social attitudes and behavior of the pupil.
 - 3.041 Report a pupil's social attitudes and behavior as observed in a variety of learning activities.
 - 3.042 Summarize accumulated data pertaining to the pupil's social attitudes and behaviors.
 - 3.043 Identify other sources and evaluative techniques which could be used to improve the appraisal of a pupil's social attitudes and behavior.
- 3.05 Describe the family and community background of the pupil.
- 3.06 Develop a summary description of a pupil's learner characteristics acknowledging the relationships among his intellectual, physical, emotional, and social traits.

4. PLANNING LONG-TERM AND SHORT-TERM LEARNING PROGRAMS WITH PUPILS

Individualized learning places new responsibilities on the learner including planning, managing or organizing, directing, and evaluating. However, these endeavors are not pursued alone by the pupil. Rather a new partnership between the pupil and teacher is formed. This is a significant change from the prevalent authority base existent in too many classrooms.

The teacher, too, becomes a learner (i.e. about pupils, about objectives, about hypothesizing conditions.) A new partnership WITH each child will manifest itself in true individualization.

With the pupil, the teacher will:

- 4.01 Integrate data on his over-all achievements and his learner characteristics into a long-term program that spells out the relative emphasis to be placed on different types of learning goals and on work within different curricular areas.

- 4.02 Utilize a pretest to specify what learning objectives a pupil will next undertake.
- 4.03 Utilize data on his characteristics as a learner in selecting the mode and setting and criterion for his individual learning.
- 4.04 Select materials and equipment that he will employ in the given learning task.
- 4.05 Select the instructional methods to be employed with his learning task.
- 4.06 Provide for him to take alternative routes toward the learning objectives.
- 4.07 Provide for him to employ self-direction in performing the learning task.
- 4.08 Provide for obtaining data on his performance of the learning task for use in assessing his progress and identifying his difficulties.
- 4.09 Estimate when he will complete the learning task.
- 4.10 Plan for interrelating his learning task in one curricular area with concurrent learning tasks in other areas.
- 4.11 Plan for his group learning situations.
- 4.12 Determine the means by which the pupil will request assistance or teacher will volunteer help.

5. GUIDING PUPILS IN THEIR LEARNING TASKS

The role of the teacher in an individualized program includes several new dimensions. In a general sense, this image repeatedly illuminates the guidance function of teaching. It is visible when assistance is provided to the pupil who is experiencing difficulty. Other pupils are helped when provisions are made for equipment, materials, special-need groups, and alternative activities. Thus, regardless of the manifestation of this role by teachers, guiding behavior emerges from awareness of individual needs, knowledge of several procedures, and willingness and determination to assist the pupil.

The teacher can:

- 5.01 Diagnose nature of difficulty.
 - 5.011 Listen to pupil questions.
 - 5.012 Probe empathetically.
 - 5.013 Refer to appropriate records.
 - 5.014 Consult with colleagues.
- 5.02 Record the findings of the diagnosis in those situations revealing a significant pupil obstacle or inadequacy of curriculum materials.
- 5.03 Define the extent to which the pupil has utilized alternative approaches to the learning task.
- 5.04 Assisting the pupil immediately by examples, questions, prompting, hypothesizing, clarifying, organizing data, etc.
- 5.05 Provide the pupil with a peer tutor.
- 5.06 Convene special help groups around specific learning tasks.
- 5.07 Provide for pupils' working on an independent, pupil-team, or subgroup basis as called for in their individual learning plans.
- 5.08 Schedule the pupils in the class to provide them with access to the space, equipment, and learning materials they require.
- 5.09 Make provisions for safety, pupil mobility and volume control.
- 5.10 Orient pupils to the schedule for the learning plans, to any new materials or media they will be using, and to any guidelines they will be following.
- 5.11 Provide time for giving pupils posttests as needed, or to plan revised or new assignments for students requiring them.

- 5.12 Provide alternative activities for those pupils who complete learning tasks without difficulties such as spontaneous fun things using mechanical, artistic, musical, and spatial interests.

6. DIRECTING OFF-TASK PUPIL BEHAVIOR *

The teacher and learner have developed a plan for learning which specifies the environmental components. Behavior of pupils which is not directly related to the learning task and specified environmental components is labeled off-task.

The prospective teacher will need a different orientation to pupil behavior because self-direction is a major out-growth of individualized approaches. Since this ideal develops in many patterns with pupils, teacher's also will need systematic and analytical approaches toward behavior control.

The teacher can:

- 6.01 Describe different approaches to behavior control.
- 6.02 Involve pupils in deciding on acceptable pupil conduct.
- 6.03 Reinforce acceptable behavior of pupil.
- 6.04 Identify sources of deviant behavior.
- 6.05 Intervene appropriately and consistently in cases of deviant behavior.
- 6.06 Initiate case studies when off-task behavior continually obstructs task completion.
- 6.07 Determine sources of inter-personal conflicts.
- 6.08 Assist in the resolution of inter-personal conflicts.
- 6.09 Distinguish between habitual and temporary deviant behavior and inter-personal conflict.

* Refer to the Appendix for a sample unit on this competency.

- 6.10 Involve pupils periodically in evaluation behavior control procedures.
- 6.11 Use consultation from colleagues and para-professionals in dealing with behavior direction.

7. EVALUATING THE LEARNER

Movement of pupils through the curricular areas is predicated on the process of evaluation. Pupils encounter each learning task on this basis. Posttest measures are used as the criteria for subsequent decisions regarding long-term and short-term plans.

The teacher can:

- 7.01 Administer, score, and interpret an appropriate pretest for determining a pupil's next learning task within a curricular area.
- 7.02 Administer, score, and interpret an appropriate posttest for determining mastery of a given learning task.
- 7.03 Develop and maintain records regarding pupil achievement, learning characteristics, off-task behavior.
- 7.04 Initiate depth studies of pupils as obstacles are noted to the successful completion of individual learning plans.
- 7.05 Organize all data generated by the system of individualization (Comp. 2.00 and 3.00) including both objective and subjective information.

8. EMPLOYING TEAMWORK WITH COLLEAGUES

Effective participation on a team requires specific skills and attitudes. The general concepts of cooperation and leadership are analyzed so that specific skills can be developed. Teams also require a continuing concern for the process by which they operate. Thus, evaluative skills are equally important for effective team functioning.

The teacher will:

- 8.01 Define the organizational patterns of teams active in the operation of the school.
- 8.02 Define the differentiated roles present on each team active in the operation of the school.
- 8.03 Participate in team activity by:
 - 8.031 Revealing the way he sees things and does things.
 - 8.032 Bringing out the essential patterns, motives, and behavior in a situation in order to receive back clear and accurate information concerning the relevancy and effectiveness of his behavior.
 - 8.033 Trying out new patterns of thought and behavior in order to experience the process of change.
 - 8.034 Helping colleagues learn how to learn from the process of presentation-experimentation-feedback.
- 8.04 Evaluate team activity by
 - 8.041 Examining the nature of the discussion to determine the emphasis which is placed on content and process.
 - 8.042 Examining the patterns of communication in the team.
 - 8.043 Examining the decision-making procedures of the team.
 - 8.044 Observing the behavior of the team from the point of view of what its purpose or function seems to be.
 - 8.045 Identifying forces which disturb team work.
 - 8.046 Identifying consulting resources needed by team.

9. ENHANCING DEVELOPMENT

The teacher who recognizes those personal traits which appear to affect her learning process or her skills of interaction with pupils will relate to learners in a new fashion. This personal understanding also leads to an improved mental health status. Such developments represent major new emphasis in the preparation of teachers, and are sometimes reflected in relationships with children.

The teacher can:

- 9.01 Participate in activities which will help reveal those personal traits which tend to limit his flexibility of behavior.
- 9.02 Analyze personal strengths and weaknesses which effect professional behavior.
- 9.03 Analyze values which affect professional behavior.
- 9.04 Analyze attitudes toward authority, supervision, learning which affect professional behavior.
- 9.05 Formulate a general plan of self-development to overcome limiting factors.
- 9.06 Modify personal behavior after interpreting evidence of performance.
- 9.07 Display self-acceptance by being attentive and responsive to pupils.
- 9.08 Display empathy and concern for children, including withdrawn, hostile, and non-productive children.
- 9.09 Display objectivity and rationality in dealing with each pupil's intellectual, personal, and social problems.
- 9.10 Evidence confidence and emotional control in responding to pressures and problems.
- 9.11 Demonstrate flexibility in personality by providing for differences to pupil ideas, wishes, actions and feelings.

- 9.12 Demonstrate flexibility by not becoming uneasy as children mention antisocial or asocial behavior.
- 9.13 Allow children to vent and express strong personal feelings.
- 9.14 Display skills for constructive intervention; and non-intervention.
- 9.15 Avoid wasting children's psychic energy by creating anxiety producing learning situations.
- 9.16 Listen to and view children's emotional behavior and irrational statements without becoming anxious and disorganized.
- 9.17 Control expressions of attitudes, feelings and emotional responses, and shifts of tone and voice and gestures.
- 9.18 Express enthusiasm for knowledge, for instruction, for furthering own learning, and for pupils achievement and interest.
- 9.19 Exhibit friendly and cooperative behavior in relationship with other members of the school staff and parents.
- 9.20 Accept the impossibility of effectively relating with every child and adult in every circumstance.

4. REQUIREMENT 4 - GUIDANCE OF TRAINEES

Guidance of trainees' is a faculty responsibility having many diverse patterns. The teacher for tomorrow will need competencies in appraising, and interpreting which will lead to self-development and working with a team of professionals. Some new relationships are required between advisor and advisee, between trainer and trainee, and trainee and program specifications. A higher degree of self direction is required of teachers.

The teacher should have the ability for:

Developing participation skills.

Developing skills of team evaluation.

Acknowledging personal traits which limit flexibility.

Analyzing personal strengths and weaknesses.

Analyzing values and attitudes.

Formulating plans for self-development.

Modifying personal behavior.

Revising long-term and short-term goals.

Planning career goals.

Participating in the counseling-out process.

Participating in program orientation.

Acknowledging program details and adjustments.

Exploring new procedures with state regulating agencies.

Providing new roles in support of the instructional processes.

Providing for clinical faculty development.

5. REQUIREMENT 5 - CLINICAL SETTINGS

The clinical settings would accommodate all the pre-service roles including observer, tutor, assistant teacher, student teacher, and intern teacher. Experienced teachers would be assigned in residence for varying periods of time in order to facilitate their training to new tasks or differentiated roles. A cooperating school district and the representative teacher organization would need to support more flexible personnel policies which would permit the reassignment of faculty for training purposes during the professional week and year.

A clinical environment has three component functions: 1) to service the pupils being educated, 2) to make a setting available for the teaching function for students of education preparing to enter teaching or for retraining of experienced teachers in residence, and 3) to provide a setting for the research function which serves teacher education and the supporting school districts through directed observations, recorded data about selected human behavior, or controlled development of materials, and deliberate evaluation procedures.

The Clinical Settings will Feature:

Individualized programs for pupils being served in a setting.

Provision of an operational setting for individualized training.

Participation in research endeavors serving teacher education.

Entering into new coalitions between universities and school districts.

Accommodating student observers and tutors.

Involving school district personnel in programs for student teaching and internship.

Promoting active in-service programs for retraining teachers in individualization.

Planning with teacher organizations.

The authors wish to make clear the fact that any set or ordering of competencies and delineation of knowledge areas must be considered open-ended. One of the challenges to the bidder or implementer of this model will be the need for faculty consideration of these same basic factors. The learning goals, the knowledge base, and the nature of the learner must be carefully studied in attempts to restructure teacher training.

The diagram portrays the interrelationship of the requirements for teacher training and the need for an expanding knowledge base.

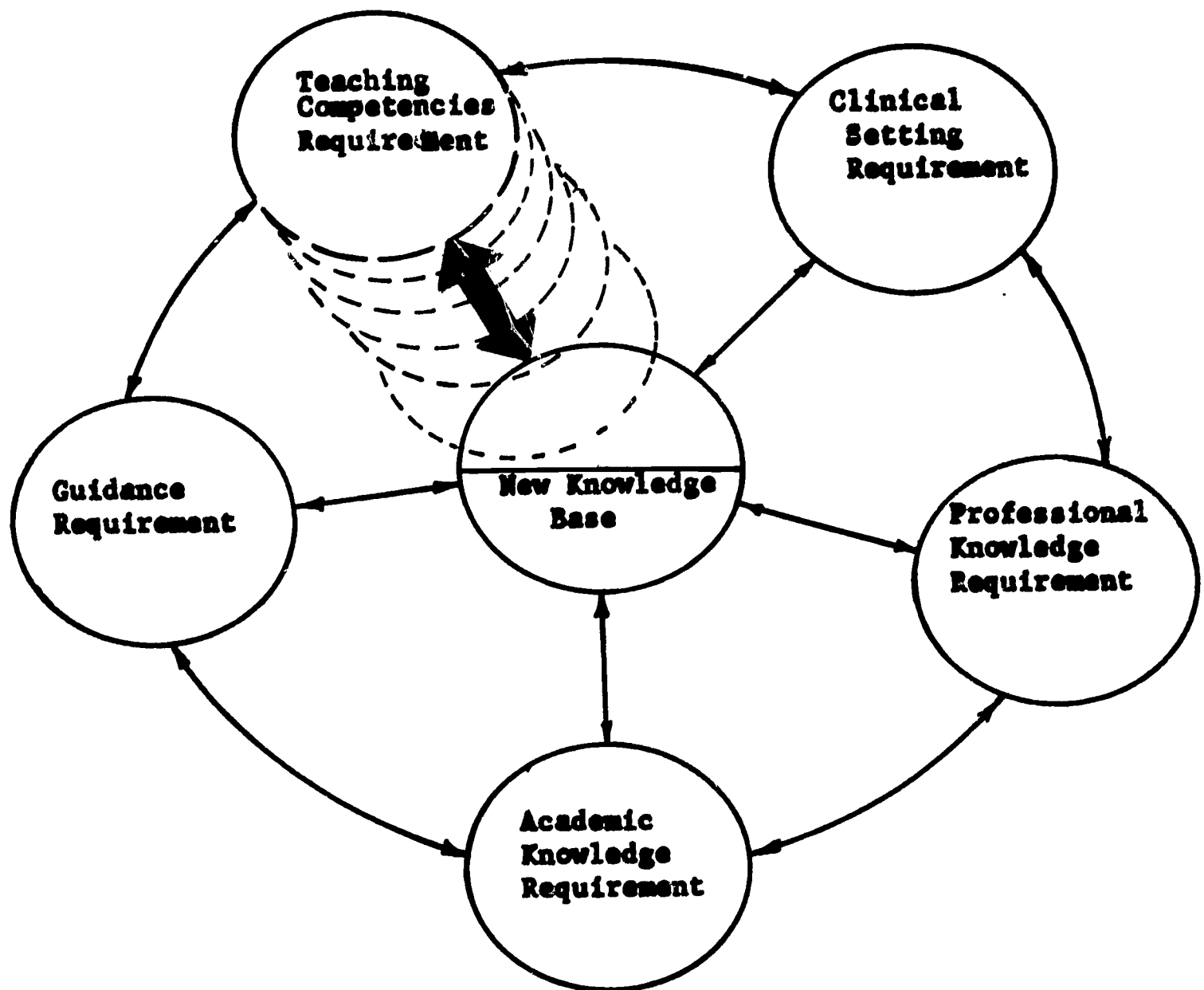

Figure No. 1 Requirements for Teacher Training

CHAPTER III. THE MODEL

A. INTRODUCTION

The theme of the University of Pittsburgh's Model for Teacher Education is individualized instruction. This proposal has been prepared by teacher educators who believe individualized instruction is only a means to help teachers assist each child in his quest for identity. In this chapter, the uniqueness of the model is identified and the manner in which the five components function as a whole is described.

In general, this model follows the basic design of most instructional models, i.e., trainees are exposed to an instructional process in order to change their behavior as indicated by the specific goals and objectives of the program. The Pittsburgh Model is unique in its commitment to assisting each teacher trainee in achieving a viable system of self-development. The admission and guidance components exemplify this concept by including a thorough process of induction interaction and reflection for the trainee. Also unique is the flexibility of the model which will permit and facilitate individual program designs for EACH trainee. The model provides an opportunity for the trainee to help select and determine the nature and extent of his training experience. These features represent a determined effort to design a program which will emphasize the human element in learning.

Two other major differences which make this model unique from most other models of instruction are the criteria of mastery and the criteria of efficiency. In relation to mastery, the trainee will be expected to work through an ordered set of objectives in the most effective way for him to obtain mastery of them. The degree of proficiency will determine mastery and his movement to another competency.

In relation to efficiency, the program will be individualized in order to provide the most efficient progress for each trainee and for the conduct of the total teacher training program. Efficiency here means that a student will not have to work in areas where he already has mastery, that his progress in the program will be geared to his own rate of learning without the arbitrary conventional programs.

THE HUMAN SIDE OF LEARNING

Self-Development and Flexibility

The Pittsburgh Model is an effort to design a program which emphasizes the human element in learning. Through a careful process of induction, interaction and reflection in the admission and guidance components the model addresses itself to the humanization of education.

A student can expect to be a partner in determining his movement through the college program. No longer will a student be exposed only to the large lecture classroom organization. Peer group interaction, independent study, small seminar group sessions, and simulated modules of instruction will aid him through his college program.

The processes of interaction and reflection will create a greater awareness of a students' strength and weakness. Possessing this awareness and the ability to adjust accordingly will help a student develop confidence and self-respect. As the student becomes involved in determining personal direction, evaluation and assessment will stimulate alternate routes for overcoming mutually determined weaknesses. No longer will the student be shackled to pre-determined courses and content outlines generally found in college bulletins. The flexibility of this program will permit course substitution as well as course elimination. The method of acquiring needed competencies will be determined by the learning style of the student.

Mastery and Efficiency

Mastery and efficiency will be serviced if the following essential aspects are provided for in the program: (1) That trainees are able to proceed toward mastery of the instructional content at varying rates; (2) That each trainee can make regular progress toward mastery of the instructional content; (3) That trainees are engaged in the learning process through active involvement including a) involvement in selecting particular units to be studied, b) involvement with pupils either through a laboratory or clinical setting, and c) involvement in the learning process through such media as video tapes of their own performance; (4) That trainees are involved in learning which is self-directed and self-selected; (5) That trainees are able to play a major role in evaluating the quality, extent, and rapidity of their progress toward mastery of successive areas in the program; (6) That materials, techniques of instruction, and classroom setting (both university classrooms and clinical

settings) are available so that instruction can be adapted to the individual needs of the trainee; and (7) That the units of instruction be determined by the competencies rather than by the more traditional academic divisions such as psychology, sociology, or measurement.

The Pittsburgh Model is an attempt to focus on people as well as content, the learner as well as instruction, and the process as well as the product. Self-development, program flexibility, mastery, and efficiency are major features of the Pittsburgh Model. With self-development and flexibility, the person is honored. With mastery and efficiency, the process is acknowledged.

THE GESTALT

The structure of this model resembles a general pattern for preparing a person to participate in activities involving human beings. These plans typically include cognitive input, affective experiences, and field participation sufficient to promote personal and professional development. The following diagram illustrates this general plan.

GENERAL TRAINING PLAN

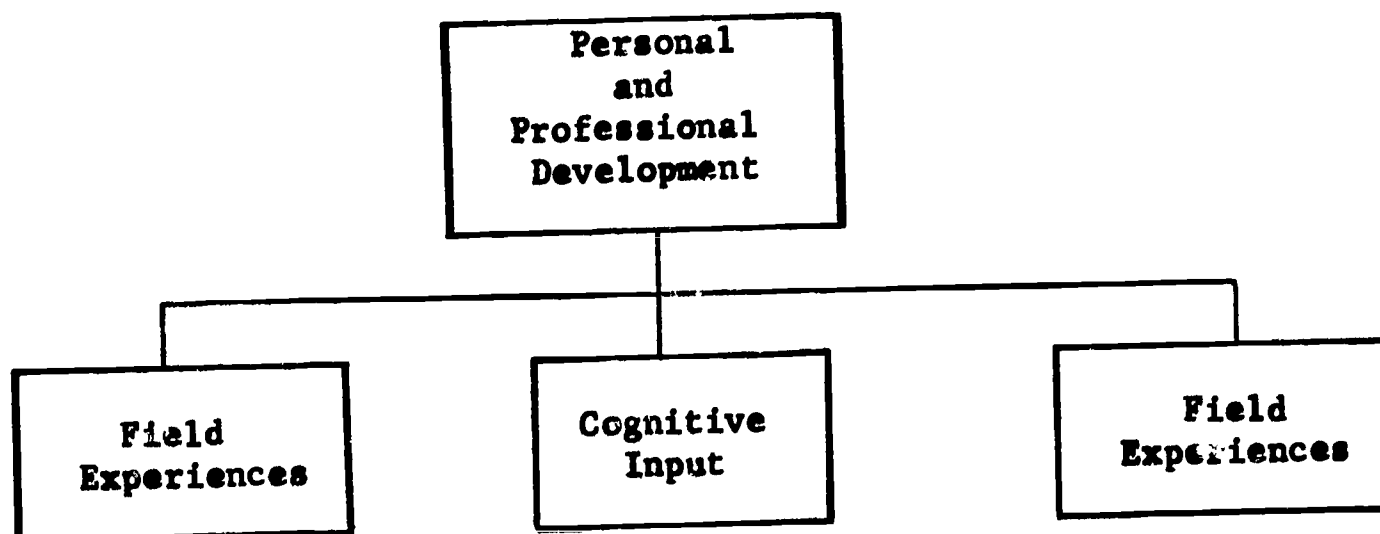

FIGURE 2. Requirements for Self-Development.

Each component makes a unique contribution to the central theme of individualized instruction, major elements tend to support and enhance each other. As a student receives the input provided by the discipline, the processes treated as academic education are demonstrated. As the student attends the clinical setting, concepts of self-development and teamwork are applied. The following model shows this interdisciplinary relationship.

The University of Pittsburgh Model of Teacher Training for the
Individualization of Instruction

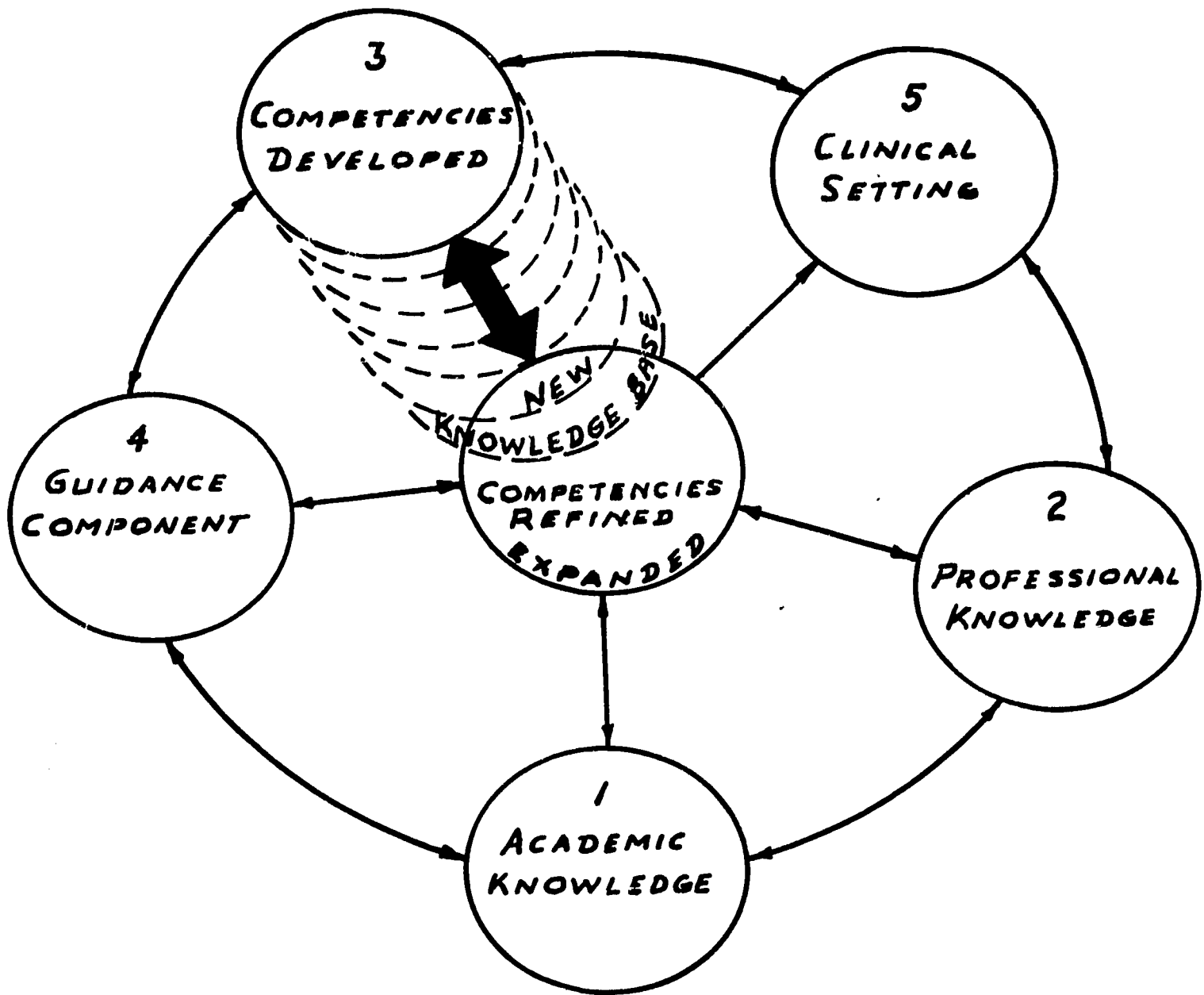

Figure 3. Shows Interrelationship of Major Components:
Expanding the Knowledge Base of the Model.

TABLE I
NATURE OF THE CONTRIBUTIONS OF
EACH COMPONENT TO INDIVIDUALIZATION

Nature	Component	Definition
Cognitive Input	Academic Knowledge	Cultural background Liberal Arts Behavioral Science School in Society
Cognitive Input	Professional Knowledge	Specifying goals Assessing achievement Diagnosing learners Learners Controlling behavior Evaluating learning
Affective Experience	Guidance	Self Development Team Work
Field Experience	Clinical Setting	Application of cognitive Input and Affective Experiences Refinement of Ed. Skills Study of the learning process

The relationships between the General Training Plan is Figure 2, and the development of the new model in Figure 3 are shown in the above Table I.

The definitions of the Academic Knowledge component, for instance, are the criteria for admission into Education.

B. PROCEDURES FOR TEACHER TRAINING

1. ADMISSION INTO EDUCATION

The general criteria for admission to education are the following: a) The candidate would be invited to present evidence that he is interested in and somewhat successful in helping children and adults; b) that he has enjoyed success and multiple interests among the academic disciplines; c) that he has utilized the American language and communication patterns successfully; d) that he has coped successfully with personal and social problems; e) that he is self-assured and confident; f) that he has good physical health; g) that his total life pattern represents broad interests; h) that he indicates open and acceptant attitudes plus understandings based on reliable and valid knowledge of all peoples in this society; i) that he understands the specifications for the teacher training program and agrees to work toward mastery.

The potential of the candidate, and the nature of his initial attitudes and commitment, will be very important in the admission stages of this model. In spite of much research (some very imaginative) little is validated concerning predictive criteria and their application. However, this model will be committed to the use of the professional judgment of faculty members who in turn are committed to the implementation of the model. The nature of individualization assumes much more personal responsibility than previously required or encouraged in a traditional teacher education program.

Improvement of teacher training rests heavily upon specific talents and personal qualities possessed by the student entering teaching as a career. To neglect or overlook talent and personal qualities would serve as an injustice to the student and to the investment in new models for teacher training. Because of the emphasis upon admission criteria each training institution will need to renew or develop coalitions with teacher organizations, school districts, state agencies and federal agencies to improve recruitment programs. It will be important to portray to potential teacher candidates that the role and function of the teacher are undergoing major change.

The model's program flexibility will provide for both admission and exit of trainees in several areas along the continuum according to demonstrated mastery of the academic and clinical experiences. The advantage of pretest and posttest capability will eventually provide a controlled entry and exit pattern which does not prevail in current teacher education programs. Figure No. 4 diagrams this admission and exit procedure.

ADMISSION TO PROFESSIONAL EDUCATION

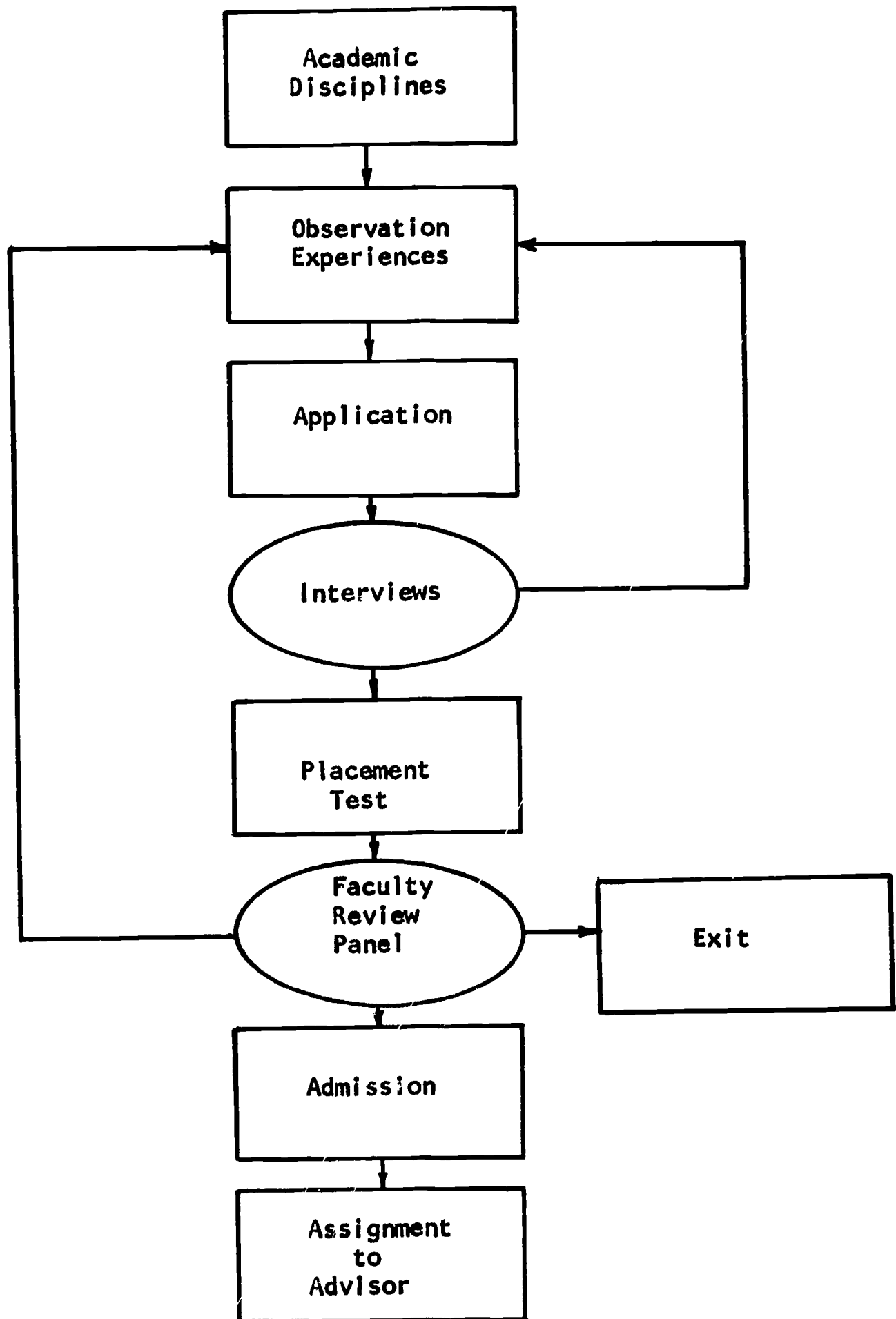

Figure No. 4. Shows Admission and Exit Procedures.

2. GUIDANCE COMPONENT

One major feature of this model pertains to the development of differentiated staff roles and team patterns in deploying the human resources of the school. While these concepts have appeared at times in various operational designs, the conventional teacher education program has not included adequate preparation of its candidates for these practices.

Teacher education for individualized instruction proposes an induction process which includes the assignment of an advisor to the student. A new procedure involving two steps is suggested. The first step involves forming learning groups of eight to ten students. These groups will continue intact throughout the education component, providing peer support during the training process. Groups will be heterogenous with regard to sex, academic performance, and career goals.

The second step pertains to the advisement process. This proposed procedure is in contrast to conventional advising practices in that group counseling will be frequently used. The advisor will consult with the learning groups, lending assistance to the students in developing skills to enhance team activity. Leadership skills will be developed and attention will be directed to the refinement of group process skills. While a large portion of the advisor's attention will be directed to the operation of the learning group, individual guidance will also be supplied as the need arises. Many of the mechanical details of advisement will be handled by the learning group. Thus, the experience of participating in a training program which uses group structure as one feature will permit the systematic development and application of skills needed to differentiate staff roles and refine team membership.

The function of the guidance component is to facilitate a close relationship among students and faculty. While this involvement is enacted in the three settings outlined below, the entire process is aimed toward demonstrating humanism in learning. It is also noteworthy that each segment of the pattern deals with specific personal growth conditions.

TABLE II

GUIDANCE PATTERN

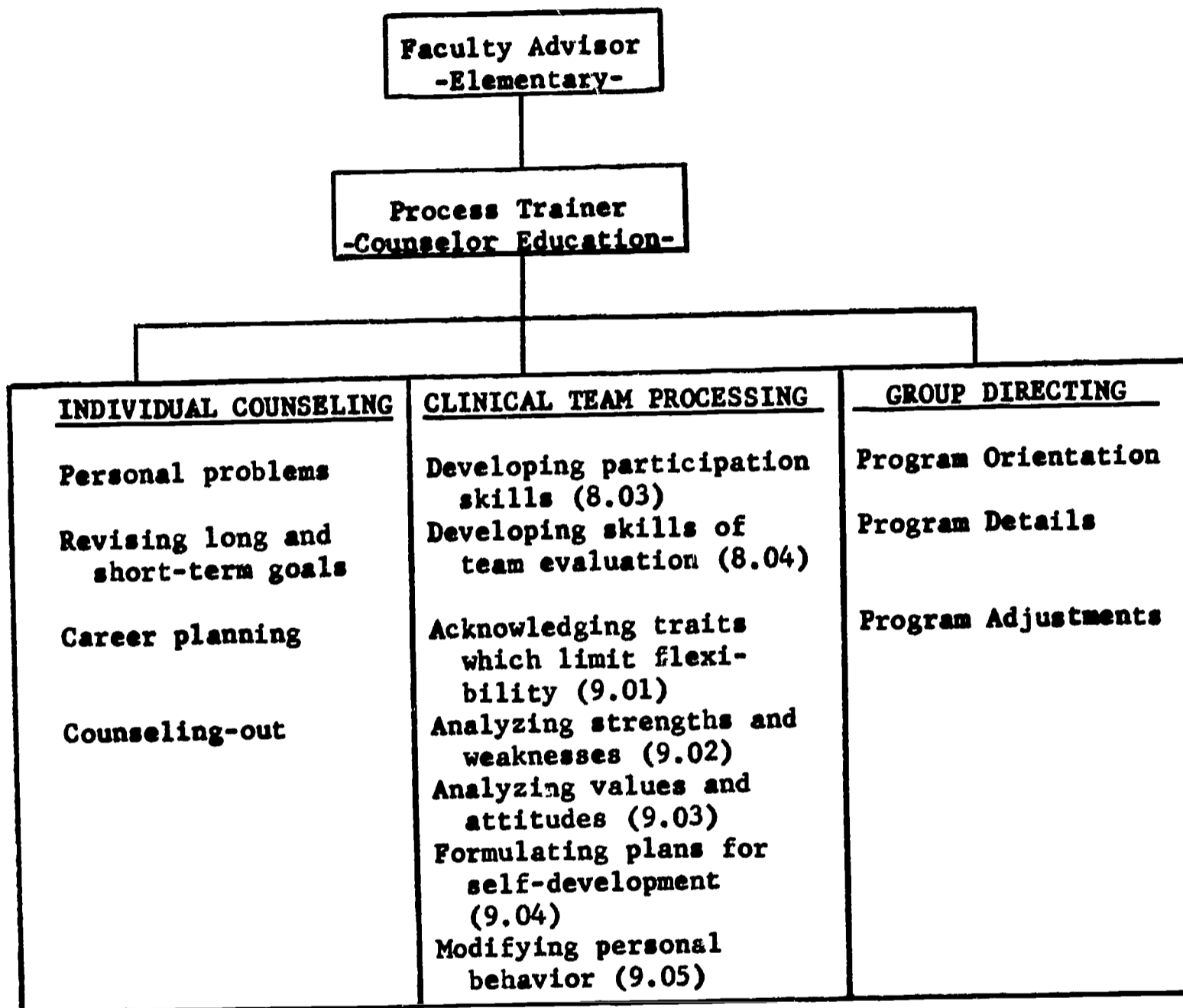

With this emphasis on the individual, a trainee can expect to be a partner in determining his movement through the college program. No longer will a student be exposed only to the large lecture classroom organization. Peer group interaction, independent study, small seminar group sessions, and simulated modules of instruction will aid him through his college program. These modules are shown in Figure 5.

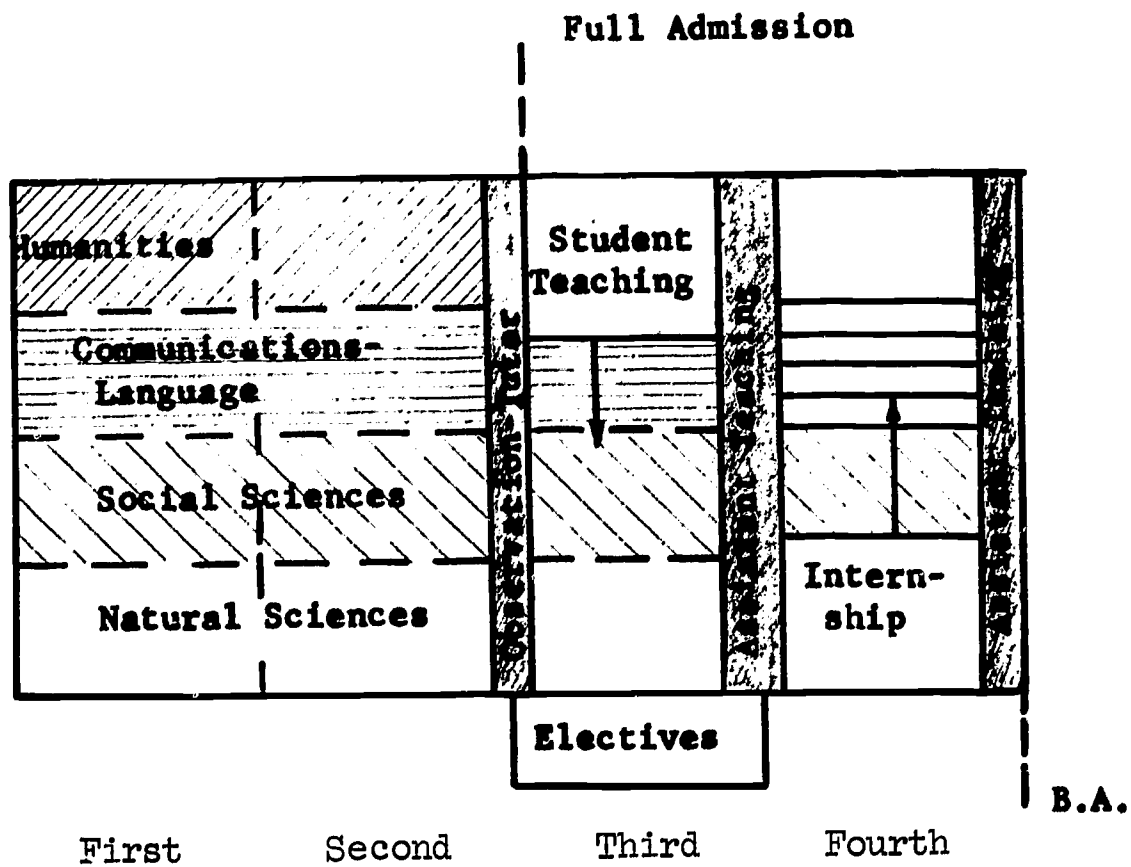

Figure No. 5 THE MODEL SEQUENCE

The chart above and its sub-divisions presents the total sequential movement of a student through each phase of the new model, terminating at the B.A. in Education Degree.

3. COURSE SELECTION (Unit Experience)

The trainee will select courses (or learning units) at four different stages according to an ordered subset of learning units desired for fulfilling the requirements for a B.A. in Education. This subset is selected either on the basis of long-term objectives, short-term objectives in that stage, performance in the previous stage and factors such as facilities available at school, requirements laid down by the school board and the individual.

Below is a breakdown of the model sequence, Figure 5

ACADEMIC SEQUENCE

The arrangement of this design will offer the trainee a continuous content resource in communications, humanities, social sciences, and natural sciences.

With his advisor the trainee will select experience units in the liberal arts as a result of personal assessment and placement tests and/or as a result of needs discovered in his clinical role with children and content tasks.

Refer to the Appendix for proposed units on Science and Mathematics.

CLINICAL SEQUENCE

First Phase

During the first phase, the trainee will be scheduled to observe and participate in the activities of the clinical setting. Data will be collected about his attitude, inter-relationships and successes as a tutor. The behavioral data and faculty judgment will form a part of the new basis for full admission into the training program.

The amount of time devoted to this segment of the program by the trainee is in direct relationship to his interests and faculty assessment. He could be trained for specific observation skills (among others) which would facilitate data collection to advance the base of knowledge about human behavior.

At the end of the trainee's first phase, he will make application for a student teaching experience. His entry will be based upon appraisals made by his advisor and other faculty members.

Observer-Tutor

Second Phase

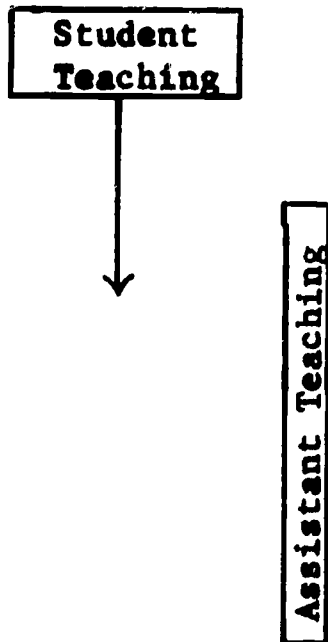

During the second phase, the trainee will serve a dual role. He will be an assistant teacher part of the time and a student teacher part of the time.

As a student teacher, 100% of the trainee's time will involve working with pupils for the purpose of observing his level of mastery in the competencies. He will function in a team situation supervised by clinical faculty members.

The trainee, in his role as assistant teacher, will be provided clerical experience, teacher aide experience and tutoring experience, while rendering valuable service to the clinical team.

This type of experience is designed to provide continuous contact with pupils in both small and large groups, and in all phases of an elementary school program.

Third Phase

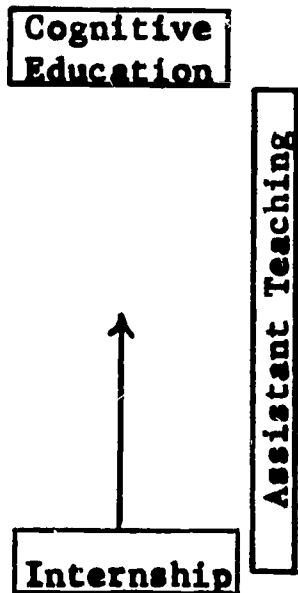

During the third phase, pupil contact will continue. Team membership and each role or function will be analyzed. At this stage it is safe to assume some trainees will be exhibiting a great deal of competency mastery suggesting some experience in a leadership role.

At the internship level of experience, curriculum decisions, communication with parents, and other responsibilities will be added to his accountability range. The internship will continue until the specified degrees of mastery are achieved.

Cognitive units in liberal arts and education will continue and will be scheduled by the trainee and his advisor.

C. CLINICAL SETTINGS FOR TEACHER TRAINING

The clinical environment* in teacher education serves three distinct functions: (1) a service function to the children or youth being educated, (2) a teaching function for both the students preparing to enter teaching and experienced teachers in residence for re-training, and (3) a research function to serve teacher education and the supporting school districts through directed observations, recorded data about selected human behavior, controlled development of materials, and deliberate evaluation procedures.

Few adequately developed clinical environments presently exist in teacher education. Very few feature a thematic approach whereby a university and school district, with full support from teacher organizations, Federal and State Agencies have established a individualized school setting for teacher training, curriculum refinement, materials development, systematic behavior analysis, and evaluation.

The clinical settings need to accommodate all the pre-service roles including observer, tutor, assistant teacher, student teacher, and intern teacher. Importantly, the in-service dimension of teacher education will receive greater priority in more visible and carefully established environments. Experienced teachers will be assigned in residence for varying periods of time in order to facilitate their training to new tasks or differentiated roles. University graduate credit or competency experiences would be designed for the clinical setting. A cooperating school district and the representative teacher organizations will need to agree upon personnel policies which will permit the re-assignment of faculty for training purposes. Whenever possible, retraining of teachers will be done in teams. Team training implies experiences which would adequately prepare personnel to function effectively together, in differentiated roles.

Tutors, observers, student teachers and assistant teachers will be involved in the clinical settings for varying periods

*"Clinical environment" refers to all of the situations, places or settings in which a prospective teacher learns about instruction through teaching children, being taught, simulating teaching, or through carrying out such instruction - related activities with pupils, parents or colleagues as materials development, materials and method testing, conferring about pupil growth, or curriculum designing. Usually the clinical environment for this model is a school building, encompassing all of its parts and facilities.

dependent upon individual progress. Each role should contribute to a professional team serving children. Consistent models of exemplary behavior, technique, materials, and evaluation would form the clinical curriculum. The opportunities to practice would be available throughout an undergraduate program. Student teachers will participate as a team member, with different team members monitoring their performance. Teaching interns could be utilized in settings outside the clinical buildings only as part of a carefully designed and balanced program. The traditional (1:1) student teacher-cooperating teacher model lacks relevance in an era of the differentiated staff. New teacher candidates will be exposed to many models of teacher learner behavior. The assorted roles of tutor, observer, assistant, student, and intern provide more potential for versatility and mastery than in traditional training settings.

A clinical teaching staff will be cooperatively selected by the school district and university partners in the teacher education coalition. The resident staff will be of permanent composition blended with some teachers there for brief tours of assistant teaching as they complete short-course retraining. Assignment to the resident staff will be recognized monetarily and designated by teacher education as of prime importance. Tours of three or more years in the clinical setting will ensure continuity of program. Whole faculties could be retrained by selective residence within the clinical environment over a period of time. The relevancy of training will be carefully designed, controlled, and measured in such settings.

SIMULATED CLINICAL SETTING

The following description of a clinical setting has been developed in order to simulate an operational model of this concept. This method is used to clarify certain elements of the proposed model such as role differentiation, school district-university coalition, observer-participant, student teaching, assistant teaching, internship, pre-service and in-service linkage, clinical team, and resident team.

Central Elementary School has an enrollment of 700 pupils. The organization plan is K-6. Twenty-six classroom teachers are assigned to this school. The professional staff also includes a principal, counselor, and teachers of Art, Music, Physical Education, and Library. Other professional staff members servicing the school on a limited basis include a social worker, psychologist, nurse, doctor, and dentist. Several necessary non-professional employees are employed including a community agent and

and teacher aides. A team from the university staff regularly participates in the activities of the school which relate to learning, training, and researching.

In this example, the activities of a group of 100 children and the related professional staff and non-professional group are isolated for part of one day. The involvement of children and staff is characterized by individualization.

The physical facilities of Central School are flexible to the point of accommodating a variety of needs. The day opens with a team planning meeting. Included on the team are four teachers, one counselor, two teacher aides, one teacher educator, and five university students preparing as teachers. The deployment of students and staff for the first hour is such that several separate learning activities are operating simultaneously.

A large part of the group of pupils are engaged in their individual learning plans. This group is managed by one teacher, two aides, one student teacher, and one assistant teacher.

Other small groups, ranging in size from two to ten pupils, are following other learning plans which feature group participation, peer tutoring, micro-teaching or appraisal activities. Servicing these different situations are two teachers, one student teacher, two interns, and the counselor.

The remaining members of the team are attending to a variety of operations including the video-taping of a tutorial set, analyzing research data generated by the program, directing data collection on all students, and guiding a parent discussion group regarding the program.

Observing the entire process are two observer-participants from the university. After observing, a member of the team interacts with the observers regarding their perceptions of the clinical setting.

At the close of the day, the team convenes for the daily gross evaluation. Specific appraisals constantly occur during the day. Necessary records are completed. The team also plans for the next day.

The Central Elementary School illustration includes all the elements of a clinical setting. Pupils are being serviced, students of education are being prepared, and research is being conducted as the program operates. Techniques such as the micro-teaching are being used to clarify and conceptualize the decision-making process of interacting.

The team regards the daily operation as data for the process of self-renewal. Thus, in-service training for one or two days a year is not necessary. Periodically, certain depth studies are prepared on the basis of program feedback. Seminars are convened on a need basis.

Differentiated roles are illustrated by the wide range of activities which are occurring simultaneously. Thus, different teacher practices and behavior is of prime importance. The clinic team is totally immersed in the activities of this group of 100 children. This team is one part of the resident team or total school staff.

School district-university coalition is evident by the participation of students in the training process and by the involvement of a teacher educator in the program at the operational level.

In summary, the clinical setting is an environment which is conducive to a broad base training experience. As these settings are formed into a network of schools, they will provide a resource for other schools to grow.

Effective clinical settings are not likely to be developed unless new practices and policies are initiated in schools pertaining to personnel, equipment, and material. The problem of personnel is a major concern. Very often this concern by school districts tends to expedite the development of these training settings since the coalition includes a substantial participation by university personnel in the operation of the school. However, the extent of involvement in a clinical environment by the university will vary widely. Agreement on this matter is one of the first steps in building an effective partnership. The University will tend to insist on certain minimums while school districts will probably be more concerned about problems generated by maximum involvement. This situation is illustrated by referring to the simulated Central School.

TABLE III

CENTRAL SCHOOL
SIMULATED CLINICAL SETTING
PERSONNEL
700 PUPIL SCHOOL

(100 pupils at each of seven age levels)

PERSONNEL	MINIMUM INVOLVEMENT		MAXIMUM INVOLVEMENT	
	Clinical Training Team	School Faculty Team	Clinical Training Team	School Faculty Team
PROFESSIONAL				
Principal		1		1
Counselor		1		1
Social Worker		1		1
Health Team		1		1
Psychologist		1		1
SPECIAL INSTRUCTORS (Art, Music, Physical Ed., Library)		4		4
TEACHER EDUCATION TEAM	1		1	
TEACHERS	4 (1 team)	28	28 (7 teams)	28
NON-PROFESSIONAL				
Secretary		1		1
Community Agent	1	1	1	1
Aides	2		14	
TRAINEE				
Observer-Participant	3		21	
Student Teachers	10 (1 team)		70 (7 teams)	
Assistant Teachers				
Intern Teachers				

The above minimal levels reflect the team training feature of the model: the extent of involvement will vary from time to time.

Role differentiation is a concept directly associated with teamwork. Generally, the idea implies a kind of 'division of labor.'

While the concept was illustrated in the description of the simulated clinical setting, more precise definitions of the various roles are needed. Only those roles of students and university personnel are represented.

TABLE IV
DIFFERENTIATED ROLES
UNIVERSITY PERSONNEL IN CLINICAL SETTING

TITLE	ROLE
Teacher Educator Team (Clinical Professors)	Participate as team members with the resident faculty in developments of the school which relate to learning, training, and researching. The University will provide staff members according to the specific need of the school.
Resident Faculty Team Clinical Training Team	All permanent faculty members in a school. Professional staff, non-professional staff, and students participating in school experiences regarding learning, training, and researching.
Observer-Participant	Student in his second phase of study who has indicated an interest in the teaching profession. He is scheduled to observe and participate in the activities of a clinic setting. Data are collected on his involvement in order to facilitate the decision regarding his possible application for admission into the School of Education.

TABLE IV (continued)
DIFFERENTIATED ROLES
UNIVERSITY PERSONNEL IN CLINICAL SETTING

TITLE	ROLE
Student Teacher	Student in the third phase of study who has demonstrated certain pre-requisite skills in working with individual pupils such that he will now devote 100% of his time working directly with pupils until certain added competencies are evident.
Assistant Teacher	Student required to have experience in the several roles represented in a team. Assistant teachers gain experience as tutors, clerks, or aides. This experience occurs either before student teaching or immediately following that experience. Students devote one/half of their time in a clinical setting.
Intern Teachers	Students in the fourth phase of preparation. Student teaching and assistant teaching roles have been experienced. Other professional activities will be encountered such as curriculum development, developing home-school relationships, research, and direct involvement with pupils in a manner other than that which has been experienced. Students devote one/half of their time in a clinical setting.

Finally, the clinical environment identification represents a major decision in the implementation of this model.

The nature of the school district-university coalition is based on certain specific factors. Since an effective clinical setting is so important, arrangements must include the following points:

1. Demonstration of the philosophic and operational compatibility between the school district and the university teacher education department.

2. Agreement between the two parties such that the role of the university is clearly identified in conjunction with the responsibility of the school district.
3. Evidence from the school district regarding its support of efforts from teacher education, including budgetary commitments, program developments, and proposed plans.
4. Indication that the faculty has appraised its attitude toward the development of a clinical setting.
5. Delineation of the manner in which the community has been informed regarding the concept of a clinic setting in education.
6. Periodic assessment of the operation to include university personnel, school district administrators, teachers, students and parents.
7. Development of communication techniques in order to facilitate a free-flow of information regarding the operation of the program.

The focus to this point has been upon the coalition between a school district and the training institution. This, however, does not complete the demands of a strong coalition or partnership. Two additional agencies or groups must be a part of this new coalition - (1) Teacher organizations and (2) Federal and state agencies. To overlook these two groups would be foolhardy as well as damaging to the formation of a coalition.

The inclusion of these two groups in the formation of a partnership enhances the position of the clinical setting. Teacher organizations must be very much aware and very much supportive of the ideas of the clinical setting. The state agency must also be aware of the ideas of the clinical setting but must also provide approval to the certification agency.

D. FACULTY INSTRUCTIONAL MODES

A major revision of instructional patterns throughout education has been overdue. It seems likely that the proposed model will facilitate developing more effective teaching methods in higher education. In the past, individualization was treated by most teacher educators at the knowledge or cognitive level. Many years of discussion about the concept resulted in few acceptable models. However, the proposed plan for individualization

at the teacher education level is founded on strategies directed toward student internalization -- the major process of the affective domain.² As internalization develops, the student attends to phenomena, responds to them, values them, and conceptualizes them. In this manner, he becomes an advocate of individualization. Thus, while individualization requires certain teacher knowledge with regard to specifying, appraising, and planning, the operation and implementation of these competencies also relies heavily on the process of internalization by students. In brief, the student must first experience his own learning in an individualized pattern before he can practice the art. Therefore, the faculty in higher education cannot continue using teaching techniques which are inconsistent with the principles of individualization if the operation and implementation of this concept is their real concern.

The proposed instructional mode for university faculty includes six processes as described below and shown on the following diagram:

1. SPECIFYING LEARNING GOALS.-- The higher education faculty must specify learning outcomes in terms of manageable and observable behavior to --
2. ASSESS STUDENT ACHIEVEMENT OF LEARNING GOALS.-- which suggests and indicates various degrees of sophistication regarding the learning outcomes.
3. DIAGNOSING LEARNER CHARACTERISTICS -- is necessary for creating the most efficient means of mastering the learner outcomes, and --
4. PLANNING LONG-TERM AND SHORT-TERM LEARNING PROGRAMS WITH STUDENTS.-- Planning is done cooperatively with the student, utilizing data from numbers two (2) and three (3).
5. GUIDING STUDENTS WITH THEIR LEARNING TASKS -- implies aiding the student in his endeavor to achieve mastery of the learning outcomes. Help can fall into many categories-- material location, problem identifications, problem clarification, direction, etc.
6. EVALUATING THE LEARNER-- is done, naturally, in terms of the specific learning outcomes previously identified. The results of the evaluation then determines the new learning outcomes.

² David R. Krathwohl, Benjamin S. Bloom, and Bertram B. Masis, Taxonomy of Educational Objectives, Handbook II: Affective Domain, p. 44.

UNIVERSITY OF PITTSBURGH MODEL

GENERAL INSTRUCTIONAL MODE

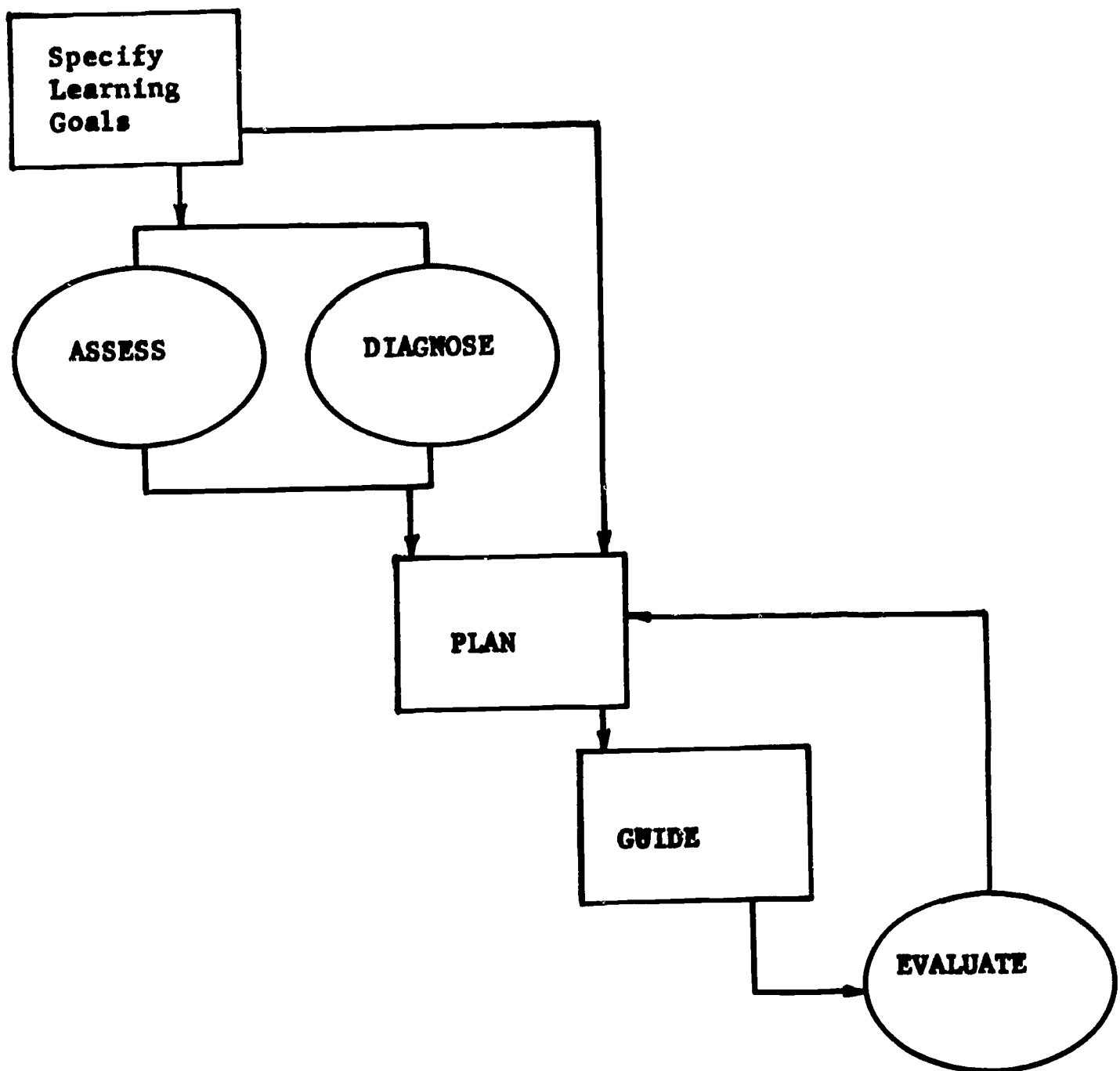

Figure No. 6 FACULTY-TRAINEE INSTRUCTIONAL MODE

CHAPTER IV. IMPLEMENTATION OF MODEL

INTRODUCTION

Individualized instruction is the central theme of this model. The model requirements for teacher training include (1) academic education, (2) teacher competencies, (3) professional education, (4) guidance and (5) clinical setting. Each of the five elements represent major contributions to the model design. These requirements also represent a formidable challenge to the Model Implementor.

In a general sense, the University of Pittsburgh Model represents a plan to prepare elementary teachers by having them experience individualized instruction throughout the preparation period. The model also includes a strategy for promoting a productive partnership between research and teaching. These proposed changes represent considerable developments in teacher education.

Educational reform of the recent past has been analyzed from at least two points of view - as products or as processes. The proposed products of this model will probably be examined in depth. However, the authors believe that the procedures by which this model is implemented, i.e., the process of change, also should be studied.

Much advice is presently available from those who have encountered problems in change. In the text *Innovation in Education*,³ Matthew Miles makes the following observation:

"....educational innovations are almost never installed on their merits. Characteristics of the local system, of the innovating person or group, and of other relevant groups often outweigh the impact of what the innovation is."

If one abides by this judgment, the Pittsburgh Model or any other design is not likely to be effectively introduced without a substantial analysis of the present state of affairs. Examination of such functions as the communication patterns in a system and the decision making process should precede the enactment of elaborate plans of action.

³ Matthew B. Miles, Editor, *Innovation in Education*, New York: Teacher's College Press, Teacher's College, Columbia University, 1964, p. 635.

B. ACADEMIC EDUCATION

Approximately 50 percent of most undergraduate programs either are controlled or influenced by the School of Education. This does not mean a course or experience carries an education label, but courses, sequences, or areas of concentration have been cooperatively formed through exchanges between faculties over the years. Because of this present state, restructuring the education component and part of the liberal arts component could proceed early in the model implementation.

The array of strategies which could be employed in the restructuring process are unlimited. However, the authors of this model place emphasis upon a design that utilizes the criteria which follow: (1) that both the School of Education and the academic department involved in the restructuring recognize the need for program regeneration, (2) that individualization must be understood and agreed to as the theme permeating the new organization, (3) that sufficient budget, personnel, and time be assigned to the restructuring process in order to facilitate the development of instructional units and instructional modes needed for this model, (4) that means of evaluation and feedback be established to ensure continued relevancy of program, (5) that the relationship of each academic discipline to the total program be recognized in the restructuring process, (6) that self-development of students be recognized early in their individual program, and (7) that the restructuring process be examined continuously in order to judge it as a way of establishing the grand design for restructuring the institution.

1. A two-way conversation between an academic department and the education faculty is essential to restructuring. The authors of this model have personally experienced the agonies of this confrontation. It will not be a set of easy tasks, but if teacher education is to be revolutionized it must occur. In a general sense, these partnerships are confronted with two tasks. The first regards restructuring the knowledge system.
2. The faculty members must examine their instructional modes. The new program will represent both a more acceptable consideration at the knowledge system and methods which are consistent with principles of individualized instruction.

The illustration which follows is a general representation of the tasks involved as the liberal arts requirement is satisfied. A higher degree of specificity could be obtained by continually analyzing each terminal. However, the purpose of this schemata is not to refine the task analysis, but to provide a means of surveying the problem.

ACADEMIC EDUCATION REQUIREMENT FOR

IMPLEMENTATION OF INDIVIDUALIZED INSTRUCTION

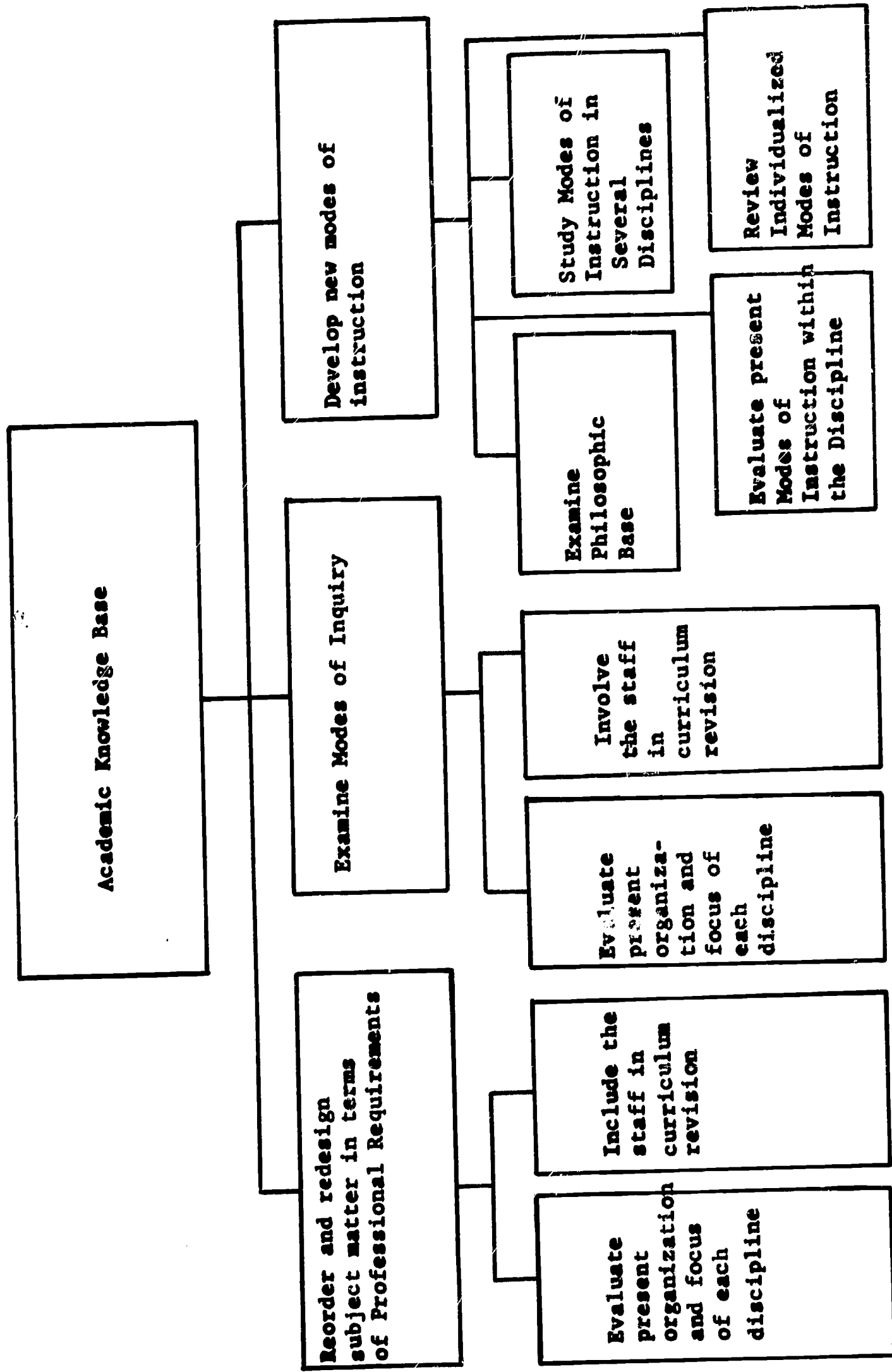

Figure No. 7. Academic Education Requirement

C. PROFESSIONAL EDUCATION

It is in the clinic setting that integration of the cognitive base with the affective domain occurs. The trainee is expected to apply his knowledge base with a child or children according to the specified learning task. When the trainee or the team discover a void or limitation of the knowledge base affecting the trainee's behavior he will be programmed for additional knowledge experiences.

The cognitive base includes the anthropological, sociological and psychological knowledges which are most relevant to the establishment of a teaching profession. The model gives priority to the extension of that knowledge base through the active participation of the faculty and trainee in data collection about clinical practices. The evidence of pupil, trainee and faculty behavior will be carefully recorded, stored and analyzed with the application of research procedures. The data will be fed back into the system to form the basis for modifying the program objectives, and to direct the participants into new modes of instruction and team function.

An analysis routine is developed in which the teachers' behaviors are described and task analyzed. These descriptions, consisting of a sequence of situation, instructional decision, and consequence (designated as elements A, B, and C) are submitted for clinic faculty evaluation with reference to their descriptive clarity, generality, and appropriateness. The analyses which are accepted by the training supervisors as representing bits of the instructional model are added to the clinical evidence.

The clinical data are artifacts in the system, not a product in any sense. The data can be a loose-leaf collection placed in the hands of each of the trainees and the supervisors. In effect, it instigates and perpetuates the examination of professional decision-making as a rational process. The procedure establishes the hypothetical nature of professional methodology and involves the practitioner in its evaluation and refinement.

Another feature, even more significant in terms of research translation, is the means this system provides to check practitioners' decisions against bodies of outside evidence. In the prototype system, two researchers, knowledgeable respectively in the fields of learning research and social psychology; examine each of the descriptions for its consonance-dissonance with evidence from laboratory research. If the hypothesis upon which the practitioners are operating is in conflict with the research evidence, the decision in question goes into the manual with a note of warning -- challenging the practitioner to take a more careful look. The dissenting researcher must also prepare a critique which is entered in the

PROFESSIONAL EDUCATION REQUIREMENT FOR

IMPLEMENTATION OF INDIVIDUALIZATION OF INSTRUCTION

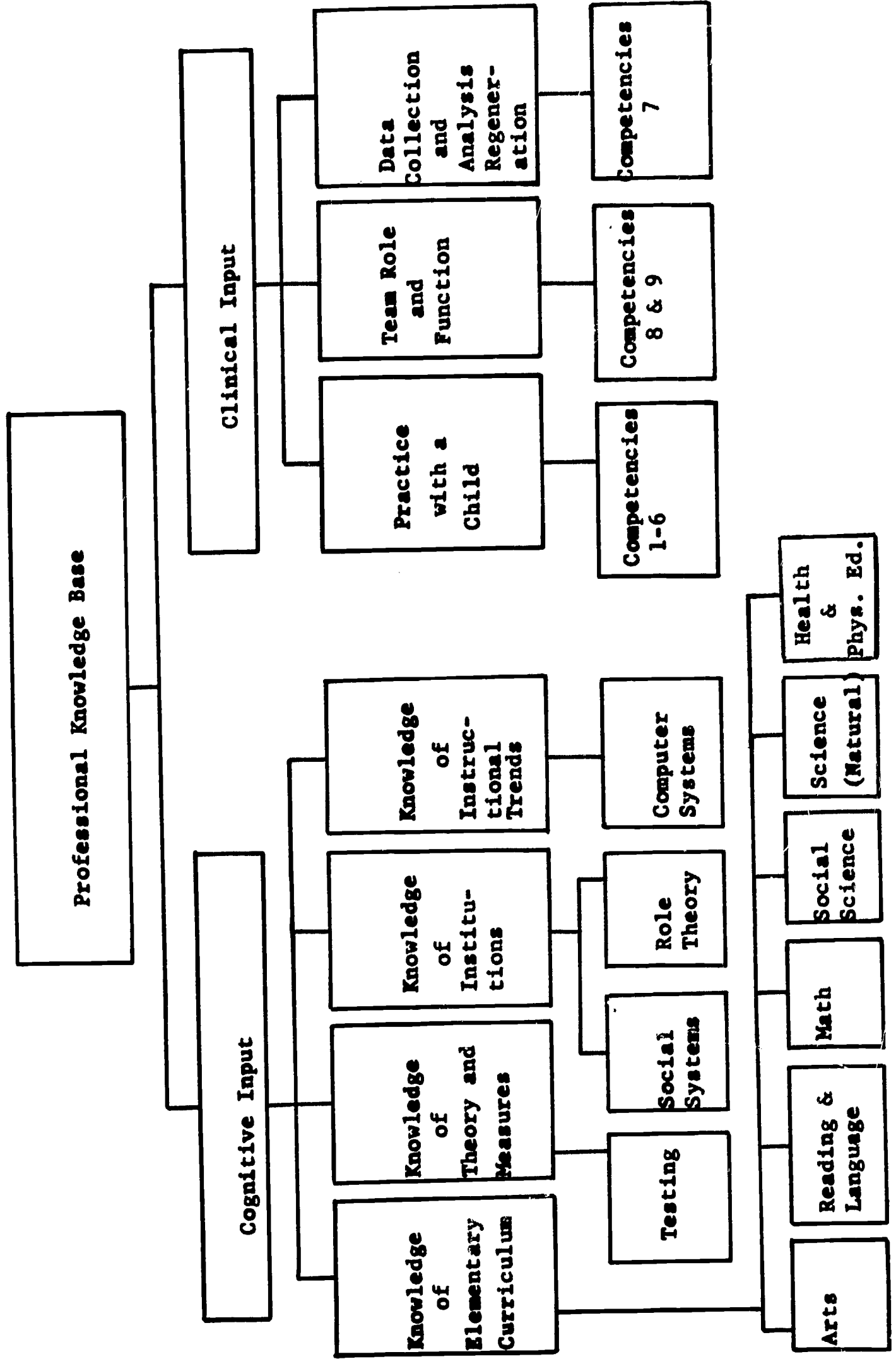

Figure No. 8 . Professional Education Requirement

clinical evidence. His critique is a brief review of the pertinent research and explanation of the basis for his challenge. It concludes with a specific suggestion for a different or modified hypothesis for practitioner decision-making. Thus the social system of the teacher practitioner is entered with a minimum of threat, capitalizing on the practitioners' curiosity and motivation to improve.

A reciprocal value accrues when practitioners, since they are free to reject a challenge, elect not to change their behavior to follow the proposed alternative hypothesis. This sort of continued dissonance highlights particular needs for new research in the learning laboratory.

APPLICABILITY

This system of routines, in which a new artifact is created as the stimulus for a more professional behavior, is adaptable to a variety of professional training situations. The essential delimitations relate to the following:

1. The training must be toward an essentially rational set of behaviors.
2. A reference base of competent practitioners must be available, preferably in the immediate social system.
3. The setting must be conducive to discussions, evaluative conferences, group decision-making.

Thus, "Clinical Analysis" has wide applicability in teacher education and in educational administrator training, especially in long-term practicum experiences and internships.

TEACHER COMPETENCIES

The Pittsburgh Model includes a set of nine competencies which represent the teacher skills needed to individualize instruction. Any list of specific teacher behavior such as this must be considered incomplete because all behaviors are not presently identifiable and new behaviors may develop as programs of individualized instruction are systematically evaluated.

Implementation of this requirement for teacher education will demand that faculty members in both Education and Liberal Arts become skillful in the nine competency areas. The manner in which the faculty is mobilized to develop these skills will not be specified in this model because of the many different techniques

presently used by faculty groups to make program decisions. It is recommended that deliberate attention be directed toward the criterion for each competency. In brief, the faculty will be faced with the problem of mastering certain skills and supplying evidence of that mastery.

The second task involved in the competency requirement is to prepare necessary trainee units for each competency. These units may be used as the criterion mentioned above. Competencies dealing with self-development and team membership are learned as trainees participate in group process experiences. Thus, the faculty must be prepared to guide such groups. At least two approaches may be used. In the first, faculty members having skill as process leaders could be teamed with untrained faculty in the direction of groups. The second choice, which is preferred by the authors of this model, involves training of faculty prior to the operation of the groups.

Finally, implementation of this requirement requires consideration of procedures to judge this trainee's skill in each area. The clinical setting is preferred for this task since trainees will be working directly with children. Thus, evidence will be available regarding the application of these skills.

The chart which follows shows the task of implementing the requirement dealing with the competencies for individualizing instruction.

GUIDANCE

Guidance in the model begins with the review and summation of the trainee's proficiency through the liberal arts component and the observation experiences. Upon receipt of his application for admission to the education component, information must be gathered through a retrieval system designed to provide relevant data for processing an applicant. Through a series of interviews and placement test a faculty review panel will then determine admission or they will begin counseling-out procedures. The faculty's function in the new model places emphasis on the system of information, retrieval, appropriate interviewing techniques and an ability to synthesize and summarize recorded data.

The guidance function, as it is presently practiced, provides the student with direction through course requirements; it does not aid students in developing self-direction, self-realization or self-evaluation. In the new model, guidance now demands a more personal involvement with the adviser to enhance personal development.

TEACHER COMPETENCY REQUIREMENTS FOR

IMPLEMENTATION OF INDIVIDUALIZED INSTRUCTION

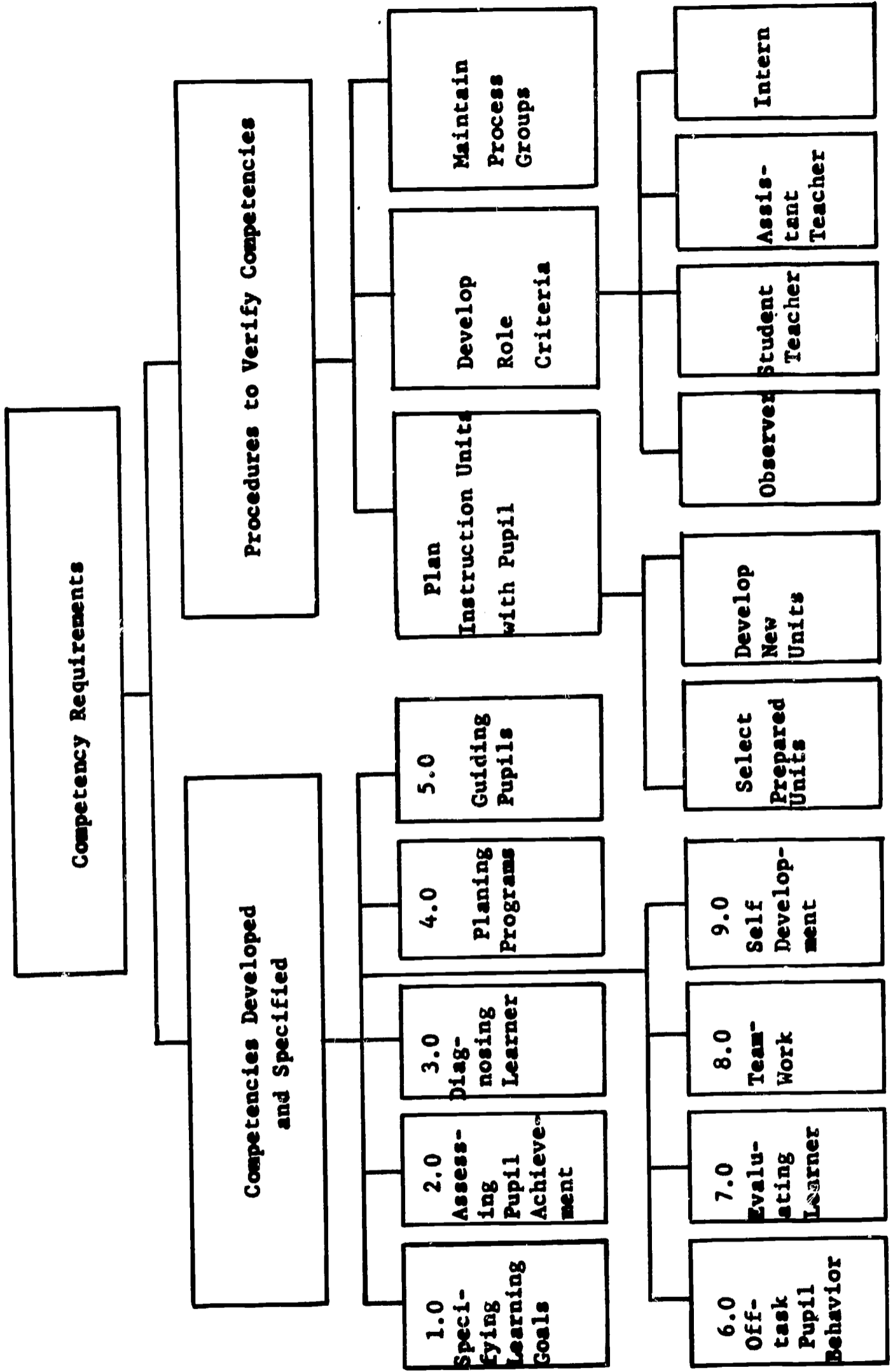

Figure No. 9. Teacher Competency Requirements

The role of the adviser is changed in the new model. He will function not only on a 1:1 ratio, but will also serve as an adviser in small and large group settings. This will demand training and a great deal of sophistication in group process work. (See - Guidance of Trainees Required in Master Training, Chapter II.)

Restructuring of the present guidance component must involve the university faculty of advisers in developing group process skills. This can be accomplished in one of two ways: (1) bring in a team of experts in group process skills to develop the skills needed or (2) pair an adviser with a person skilled in group process for on the job training.

The training of advisers in the group process skills looms as a key input for the implementation of the guidance component in the new model.

The illustration that follows represents the major tasks involved as the requirement of the guidance component are satisfied.

F. CLINICAL SETTING

This model mandates a clinical setting founded on a genuine concern for individualized instruction. This determination and commitment parallels medicine's focus on cancer, heart disease and other major health problems. Just as these crippling diseases demand the involvement of the medical association, hospitals, schools of medicine, federal and state agencies, and the public, so does the problem of individualized instruction require new coalitions.

Clinical settings of the type described in the Pittsburgh Model are not completely new. The 1968 Yearbook of AACTE/AST included a description of this concept in the contribution by Southworth. He concluded that current cooperation agreements between universities, colleges, and public or private elementary and secondary districts in teacher education should be further expanded to include representative classroom practitioners selected by the teacher organizations in each regional area.⁴ The idea was cited again by Southworth in the monthly publication of the Pennsylvania State Education Association:

" . . . New Coalitions of creative energies must spring forth to speed change in teacher preparation and continued teacher growth. Universities, school districts, teacher organizations,

⁴ 1968 Yearbook of AACTE/AST, Edited by Smith, Olsen, Johnson and Barbour, Partnership in Teacher Education, 1968, p. 141.

GUIDANCE REQUIREMENT FOR IMPLEMENTATION OF

INDIVIDUALIZATION OF INSTRUCTION

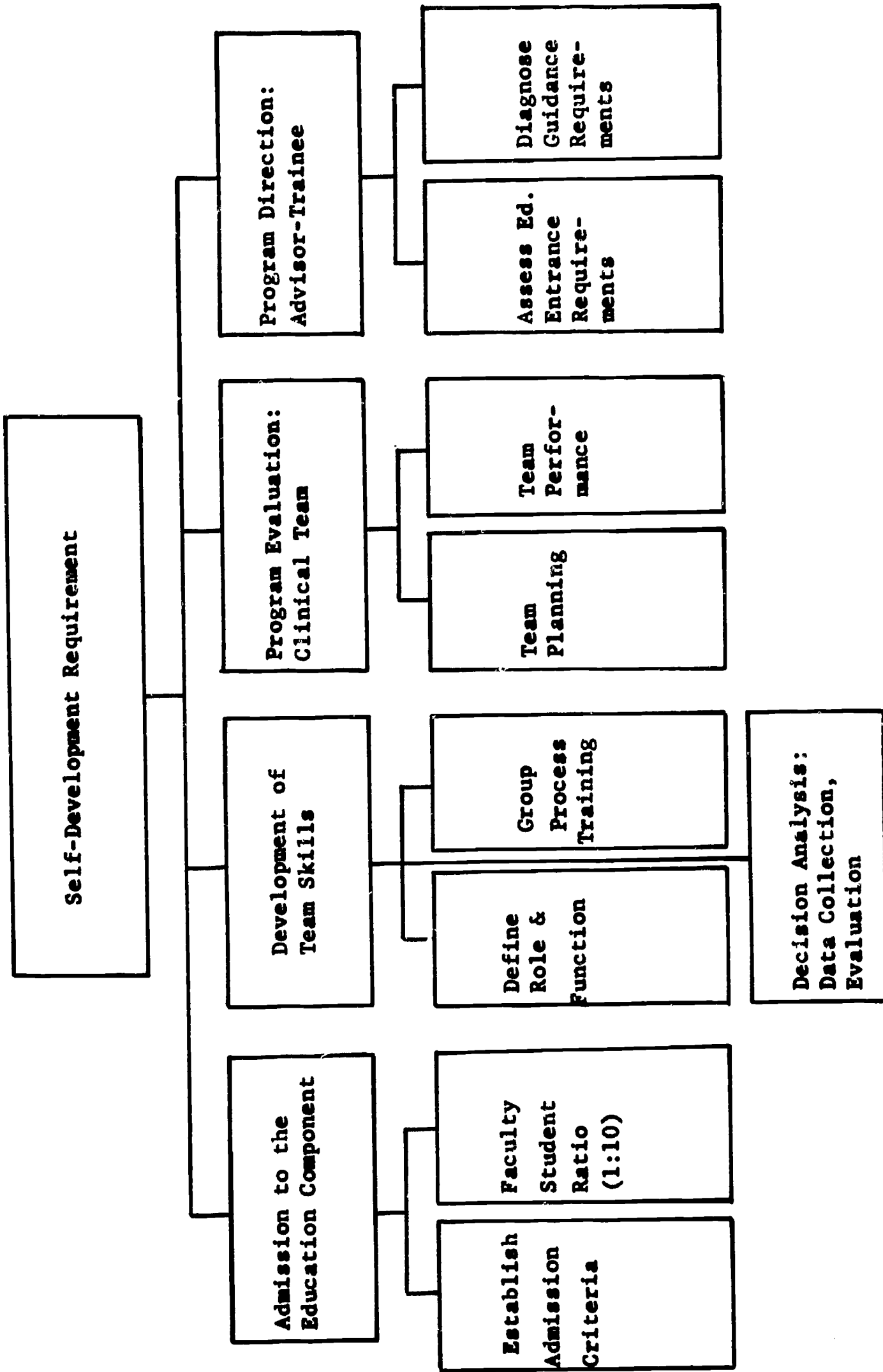

Figure No. 10 . Guidance Requirement

state departments, and other related agencies must join forces quickly. No single institution will be able to effect change in the 1970's.⁵

The first step taken in the development of clinical settings is critical. By negotiation, the four involved parties will build the new coalition. This agreement will provide a definition of the commitment of each party.

Let it be clear that the proposed Pittsburgh Model requires certain prerequisite conditions in the clinical setting. Preparation of trainees on any campus should not begin until the new coalition is formed.

The chart which follows represents the nature of the involvement process. This diagram is not complete for several other terminals could easily be added. The purpose of the outline is to provide a general indication of the task of implementing this requirement.

UNIVERSITY IMPLEMENTATION

An examination of the change process in addition to a clarification of the philosophy of individualization must precede an implementation of the model. A commitment by administration and faculty is paramount to the support of the Pittsburgh Model because of its radical departure from contemporary teacher education.

To support the Pittsburgh Model, teacher educators will have to develop four important linkages; (1) among the faculty groups within the School of Education, (2) with the liberal arts faculties who share responsibility for teacher preparation, (3) with the research agency or development centers, and (4) with the public school districts cooperating in the establishment of the clinical settings for training.

The model represented here began the linkages with its own education faculty, the public schools, and the research and development center. It did not choose to explore the dialogue with the several liberal arts faculties during the design stages.

Since recent developments in the creation of individualized curriculum have emanated from Research and Development Centers

⁵ Southworth, Horton C., "Needed: Revolution in Teacher Education," Pennsylvania School Journal, Vol. 117, No. 1, September, 1968, p. 6.

CLINICAL SETTING FOR IMPLEMENTATION OF INDIVIDUALIZED INSTRUCTION

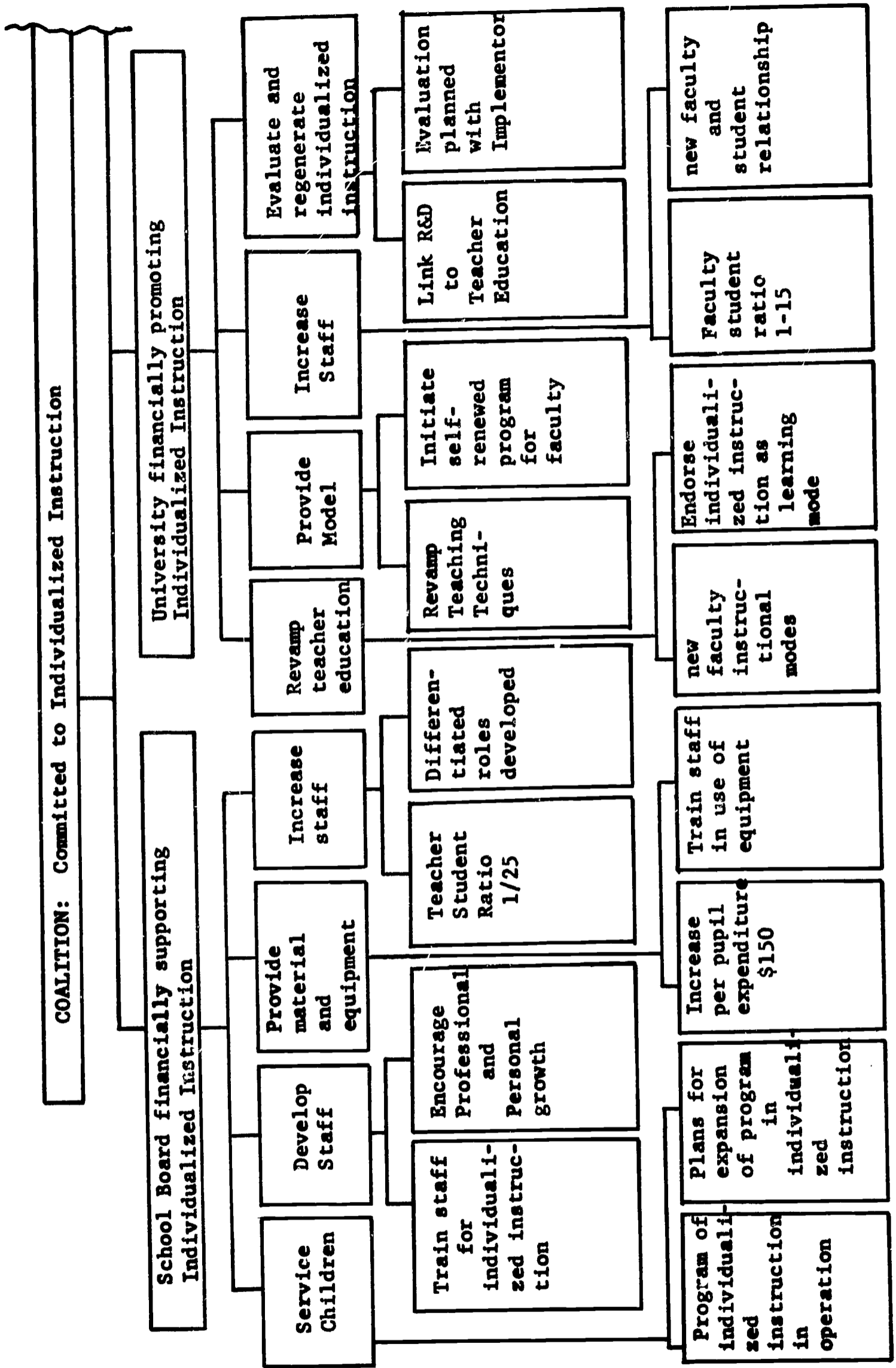
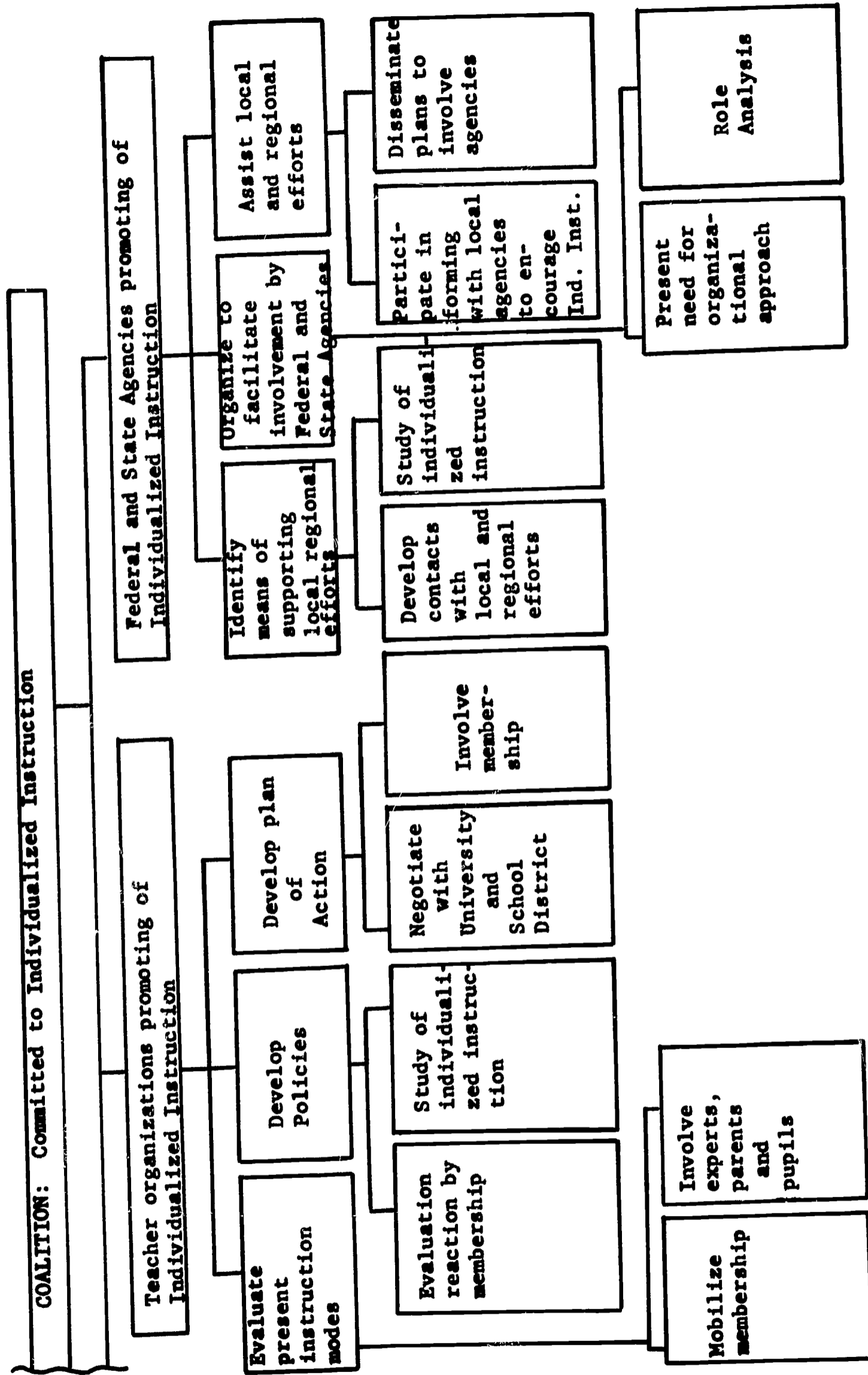

Figure No.11. Coalition for Implementation of Individualized Instruction

CLINICAL SETTING FOR IMPLEMENTATION OF INDIVIDUALIZED INSTRUCTION



it was deemed important that this model explore the teacher education-research link as extensively as possible in the design period of eight months.

Any implementer of this model will need research support in the careful specification of learning goals, task analysis, and systematic evaluation of the model components. The relationship will not be an easy one between the research oriented faculty and the operationally oriented faculty. It would be safe to state at least three major problems encumber the dialogue, (1) a common language does not exist, (2) respect between research and teacher education has not developed and (3) approaches to thought, process, and problem solving are not initially compatible or congruent.

When a university decides to implement the University of Pittsburgh Model, a series of events must occur. The chart which follows illustrates this process in ten steps:

- | | |
|--|--|
| 1. Selection of Model | The institution has decided to implement the University of Pittsburgh Model. |
| 2. Faculty, Students and Facilities Assessed | Capabilities of faculty, students, and facilities are assessed with regard to the model requirements. |
| 3. Resource Capabilities | Conclusion reached regarding capabilities of all resources. |
| 4. Goals of Overall Program | Long-term goals are specified such that these goals are consistent with resource capabilities. |
| 5. Immediate or Intermediate Objectives | Short-term goals are specifically identified with regard to facilities, material and techniques, management, and faculty. |
| 6. Acquire New Resources | Short-term goals are realized as new resources are acquired. |
| 7. Orientation of Faculty, Conventional and New Courses, and Clinical Settings | The system has the capability to induct students after faculty orientation has occurred, courses have been evaluated and reformed, and clinical settings have been identified. |

**Figure No.12 UNIVERSITY IMPLEMENTATION OF THE PITTSBURGH MODEL
SEQUENCE OF EVENTS**

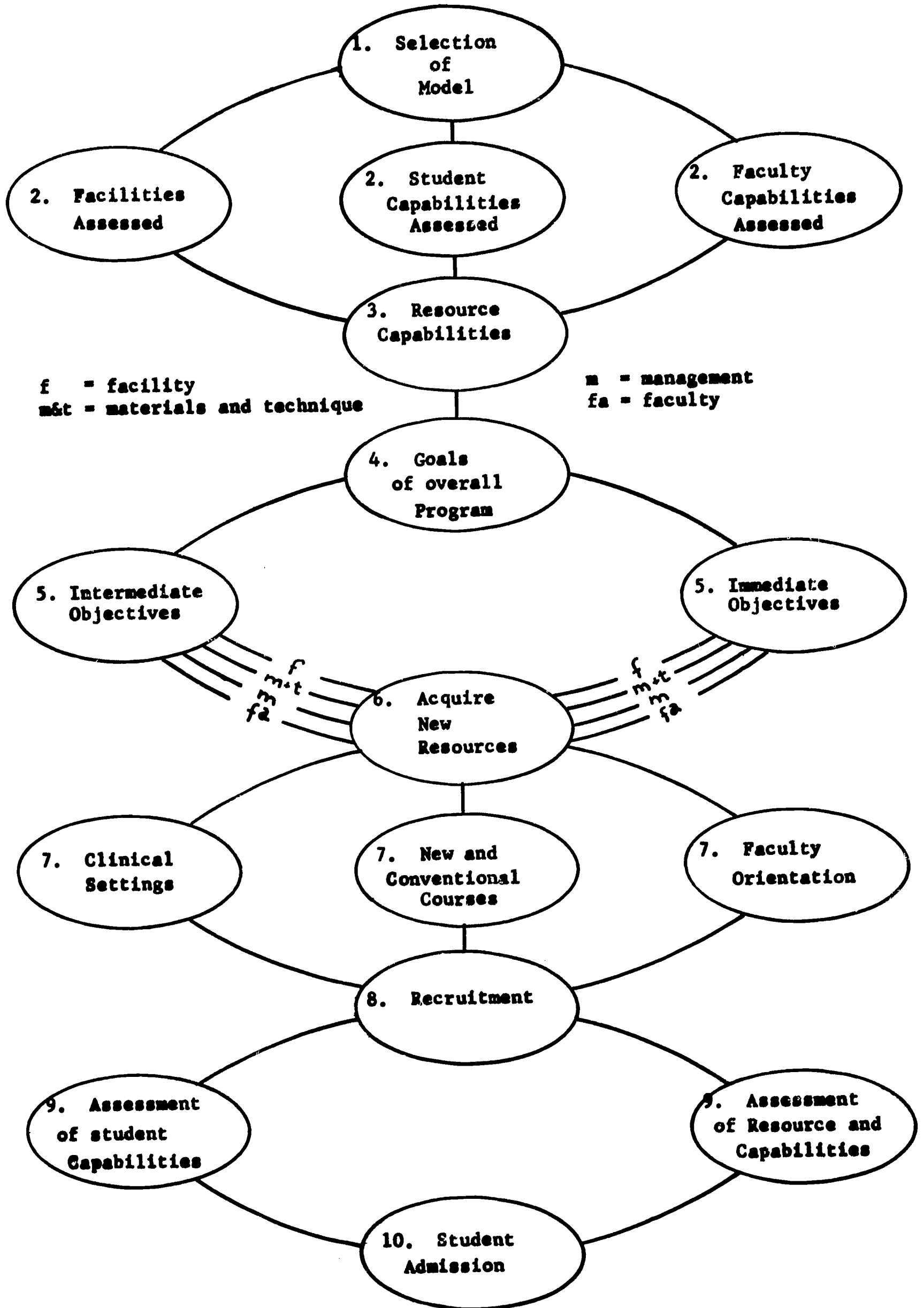

- | | |
|--|--|
| 8. Recruitment | Students are urged to apply for admission. |
| 9. Assessment of Resource and Student Capability | Resources such as faculty, facility, and material are available. Student capabilities are also assessed. |
| 10. Admission | Students are admitted on the basis of system and student capability. |

EVALUATION QUESTIONS FOR THE TEACHER TRAINING MODEL

The teacher education program which has been outlined in this model shall be evaluated for two purposes: (1) to provide information for guiding and improving your program as it develops and (2) to provide a comprehensive assessment of the program. These two aspects of evaluation are frequently formative and summative evaluation after Scriven's explication in Methodology of Evaluation.⁶

Both formative and summative evaluation require that each dimension of the individualized teacher education project be assessed. These dimensions consist of (1) the aims or criteria of the program, (2) the plan or procedures for the program, (3) the implementation or operation of the program, and (4) the end results of the program, i.e., the degree to which the objectives of the program are achieved and the efficiency with which the program permits the achievement of the objectives.

The evaluation of the Pittsburgh Model for teacher training program will provide data to answer the following types of questions relating to an individualized teacher training program.

1. Are all the competencies needed in teaching clearly stated in terms of the desired outcomes?
2. Does the list of competencies exhaust all the needed competencies for the teacher of the future?
3. Are there provisions for the manner in which the students shall work to develop these competencies: the materials

⁶ Michael Scriven, "The Methodology of Evaluation," Perspectives of Curriculum Evaluation, R. E. Stake, editor (Chicago: Rand McNally and Co., 1967).

used, the degree of proficiency required for various competencies, the application of knowledge, the determination of prerequisites skills needed for certain competencies, the ordering of competencies, and the arrangement of the competencies into units of workable size?

4. How does the plan incorporate the elements of individualization into the teacher training program so that teachers will be trained in the same manner that they will eventually instruct children? In what manner will the trainee diagnosis take place? What type of testing procedures will be used for this? What provisions will be made for the use of diagnostic testing procedures in assigning units of work to the trainees? Is every unit planned with alternate instructional paths, materials and technology? What provisions are made for the continuous monitoring and assessment of student progress?
5. What forms of environments are accessible to the trainees for individualizing instruction?
6. Is the plan developed in sufficient detail so that it can be implemented?
7. Is the plan appropriate to the characteristics (age, previous instruction, etc.) of the trainees?
8. Does the plan account for the variation of events which might require modification of the plan?
9. Does the theoretical study of professional education and the academic disciplines blend with application of learning throughout the entire training program?

Implementation: The way in which the program actually operates must be assessed in terms of the viability and efficiency with which the plan is followed and the criteria are met. In asking whether the operation of the plan fits the plan and stated criteria, the following types of questions need to be answered in order to establish the strong points of the program and modify the limitations of the program as it operates.

1. Are the behavioral objectives for competencies states unambiguously so that professor, trainees, test writers or curriculum developers can use them with clarity?

2. Is there empirical evidence that the objectives are in requisite order?
3. Is there empirical evidence that the objectives are grouped into units of appropriate size?
4. Are the objectives and units such that there are no gaps or overlapping steps in the ordering of the objectives and units?
5. Is there evidence of the validity and reliability of the various diagnostic tests used in the program? This includes both written tests and various performance tests during clinical experiences.
6. How do the procedures for administering tests and scoring procedures operate?
7. Is there evidence that the tests provide information that the trainee can use to monitor his own progress?
8. Is there evidence that the materials used are appropriate and easily accessible to the trainee?
9. To what degree does individualization take place during the program? Are there alternate routes or types of instructional materials, or arrangements by which the trainee can proceed at variable rates?
10. What type of staff training is required to operationalize the program?

Assessment: Finally, the outcomes of the program in terms of trainee performance will be evaluated to judge the extent to which the teacher training program does prepare trainees to effect various competencies required. This will require data to show:

1. Measures of the trainees performance in the classroom in the differentiated teacher roles that they may be expected to undertake in the classroom.
2. Measures of the effectiveness of various diagnostic procedures and materials for improving student performance.
3. Data to show variation in instructional materials and routes.

4. Data to show variation in instructional rates.
5. Follow-up studies on the work of trainees in teaching once they have completed the program.

The types of questions listed for the plan, operation and assessment of the teacher training program can be answered at various points in time during the development of the program in order to improve the operation of the program.

The preceding diagrams, which implemented the teacher training requirements, illustrate the use of data for formative evaluation.

The information can also be combined with all information available regarding the project for summative evaluation, however, the data will be gathered by continual monitoring and assessment at all phases of the program development in order to correct problem areas and to provide a record of program progress and change. The following diagram shows this continual monitoring process operating within the new model.

Through decision analysis, each component is assessed and evaluated, not only for its own internal consistency, but for its interdisciplinary relationship and, also, for its relationship to the philosophy of the model itself.

The Philosophy of Individualization

The philosophy of individualization is one of change, and any institution bidding on this model should make this commitment. When this vital first step has been completed, the institution can proceed to the subsequent steps which result in total implementation.

Most of the significant demands of society, the major themes of reform in education, and the new technology available to instruction and learning can be accommodated by the Pittsburgh Model for teacher training.

The highest priority is given to major restructuring of the processes and patterns confronting students at the college level. The revolution in instruction and learning must occur at all levels if pupils are to be aided in the elementary schools of America.

UNIVERSITY OF PITTSBURGH
PROGRAM REGENERATION SYSTEM

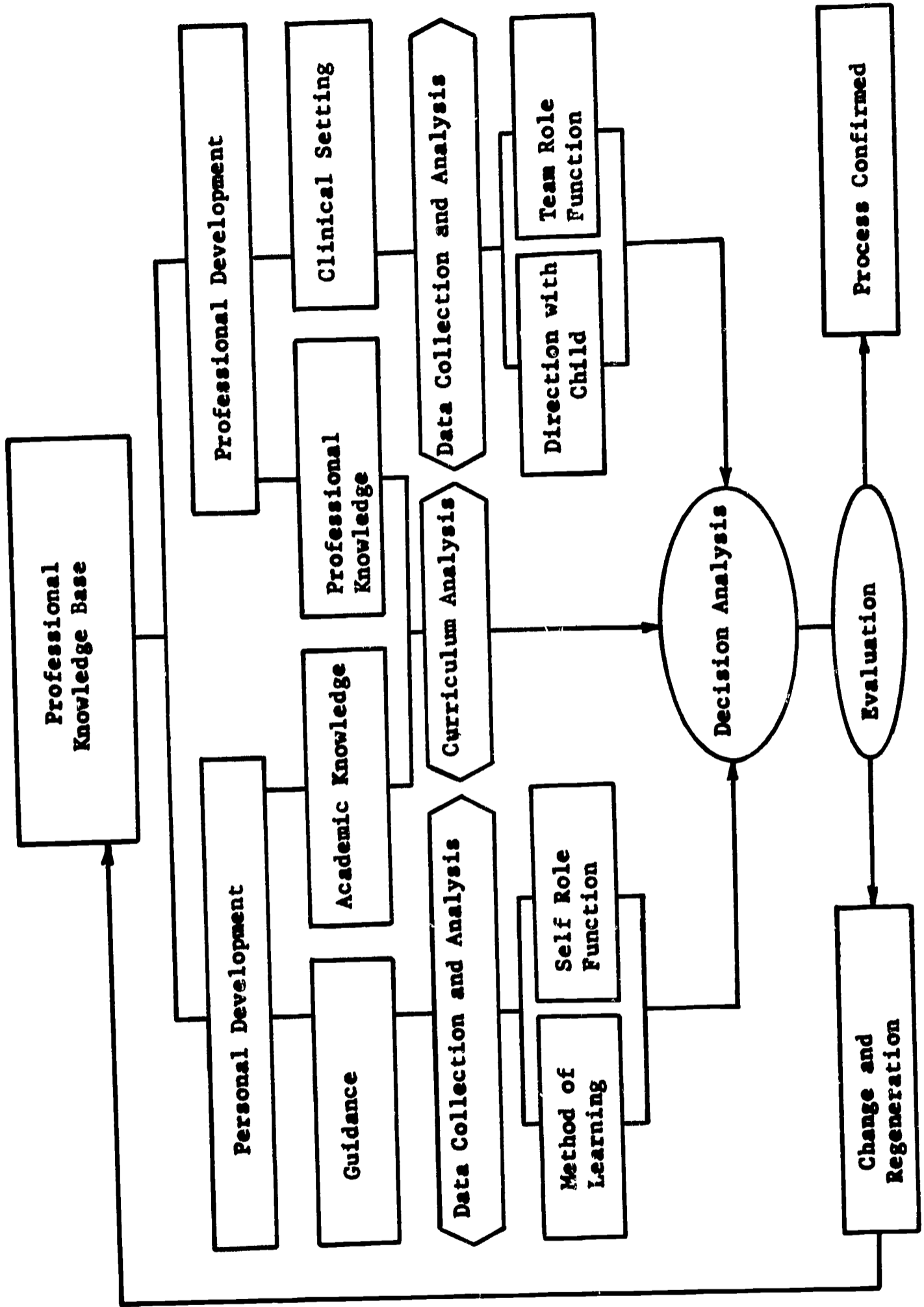

Figure No. 13. Program Regeneration System

CHAPTER V - SUMMARY: A MODEL FOR TRAINING TEACHERS TO INDIVIDUALIZE INSTRUCTION

Introduction

Individualized instruction has been an ageless dream of the schools of America. The years of effort and dialogue have resulted in very few plans and operations of this idea which could withstand rigorous examination. Through the years, this dream has turned into a dilemma as teachers have been urged by many to individualize programs only to be confronted with the reality of training lag, an economic restriction, and an operational void which exists because so few acceptable models of this concept are available.

The central theme of the new Model for teacher training is individualized instruction. A general definition of individualization is as follows: Individualized Instruction consists of planning and conducting, with each pupil, programs of study and day-to-day lessons that are tailor-made to suit his learning requirements and his characteristics as a learner. This definition focuses on instructional planning with and for each individual student before teaching him, then teaching him according to the plan. Most educators mistakenly define individualization in terms of the setting within which learning takes place, limiting it to tutorial instruction or independent study.

Group teaching can also be a part of individualized programs. Whenever, at the same time, two or more pupils are ready to study the same task in a like way through group presentation or discussion, it is proper for the teacher to assemble and teach them as a group. This is very different from most instruction today where plans are made for the group as a whole and where instruction pays limited attention to individual differences among pupils in the group. It has been assumed by the authors of this proposal that principles of individualized instruction should be used throughout the educational experience. Thus, while this model is specifically addressed to the preparation of teachers for levels of instruction within an elementary school, it is applicable to other levels.

Several chronic problems of education are directly related to the issues of individualized instruction and teacher preparation. Paramount among these concerns is in-service education. Slowly we are coming to acknowledge the obsolescence in our skills to individualize instruction. The programs of the past have been futile. In the future, we will find a new approach as training, self-development, and self-renewal become features of the daily operation of the school. This model proposes a way of preparing new professionals and upgrading the licensed practitioners to individual instruction.

Individualized instruction is the central theme of the University of Pittsburgh Model. In preparing this plan, we intended it to be clear that while such individualized programs as IPI, PEP, and PLAN have been cited in this text, the Pittsburgh Model is not a teacher training program only for that form of individualization.

In a general sense, the proposed program is quite similar to many existing plans. The student will continue in liberal arts study for the first part of his preparation. The remainder of his program will consist of several experiences in a school setting.

Major differences exist between conventional teacher education programs and the proposed model. An illustration of this point would be the matter of program flexibility -- a critically important trait of individualized instruction. In the Pittsburgh Model, this attribute will be evident as a student obtains the liberal arts input because instructional modes will be used which allow for different rates and styles of learning. Flexibility also will be obvious as students assume more responsibility for making decisions about their training. The distinction of flexibility will be noted in program planning, for no longer will courses be offered with vague descriptions regarding purpose and goals. Rather, smaller, more precise units of instruction will be used and students will have a greater opportunity to tailor the program according to their needs. This trait also will be visible during student teaching and interning for these experiences also will be adjusted to the individual.

Flexibility is a discernible trait of the proposed instructional mode. Individualized instruction as herein proposed begins with an appraisal of the learner. Instruction is then adapted to the individual. Within a reasonably short time, the effectiveness of that treatment is judged for the purpose of adjusting activities to the learner once more. This cycle, which is brief, in time, appears as an appropriate plan for individualizing instruction.

Flexibility is carefully linked to self-development which is another unique feature of the Pittsburgh Model. The adjustments previously cited in program and instruction enable self-development in a gross manner. However, underlying this focus is the reasonable assumption that students will relate to pupils in a more helpful manner if the preparation period is marked by accepting and helping behavior by the faculty.

Self-development has another dimension. It will be noticeable in the prolonged attention to group process in the model. By this technique, the student will learn how to help others identify personal

strengths and weaknesses. In so doing, students will gain new insights into their own behavior.

The teacher educators who prepared this model believe that individualized instruction is a means to a more significant goal. It will be a useful means only if it helps each child in his quest for identity. This is an endeavor of the highest priority. It is an endeavor which cannot rely totally on good equipment and material. It is an endeavor which progresses on the basis of human relationships. Thus, the teacher, or the student of teaching, must be prepared to fill this critical role. This is the contribution of self-development, for as the teacher knows himself, he will be better equipped to help others know themselves.

Learning in the fashion of the Pittsburgh Model also is marked by the concepts of mastery and efficiency. With regard to mastery, the trainee will be expected to demonstrate that learning goals have been met. Movement to another set of goals will be predicated on previous indications of mastery. However, mastery will not imply rigid standards of performance for all trainee's.

Efficiency is related to the flexibility feature. In relation to efficiency, the program will be adjusted to accommodate individuals in terms of what he knows, how he learns, and what he selects to learn. Thus, a flexible program is essential if learning efficiency is to be recognized.

The five requirements met by this model component are: 1) academic education; 2) professional education; 3) teacher competencies, 4) a clinical setting; and 5) a guidance component. The model follows a general plan for preparing a person to participate in activities involving human behavior. This general plan includes cognitive input, affective experiences, and field participation sufficient to appraise the trainee's personal and professional development. These elements are placed in a network as follows:

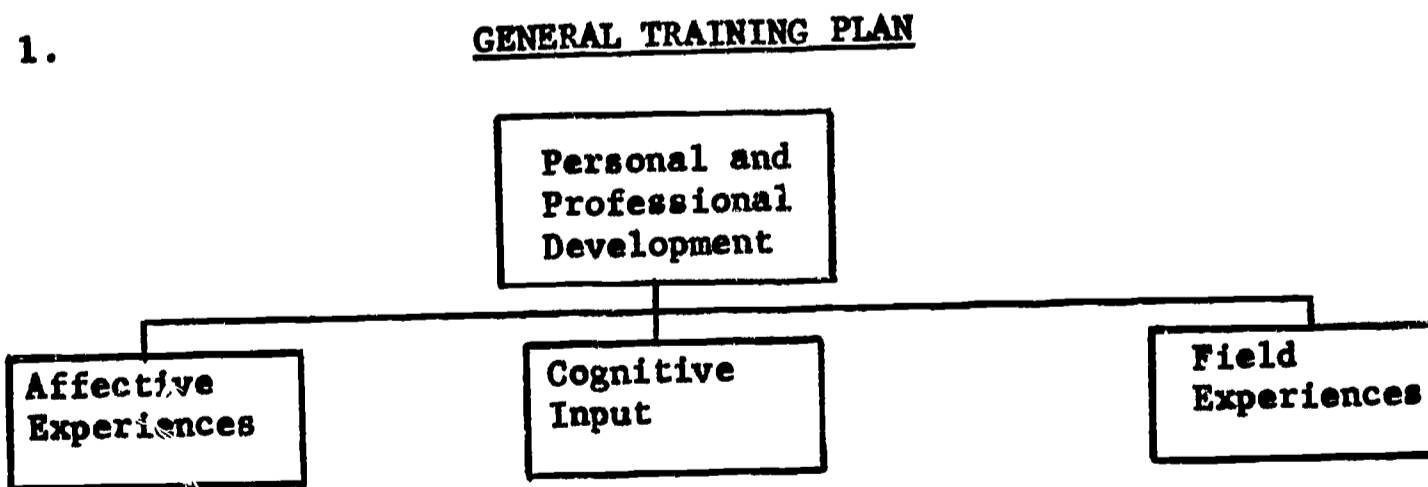

Figure No. 14. General Training Plan for Self-Development

The structure of the proposed model is more specific than the previous diagram. The sketch below illustrates the factor as it is perceived at this time: The trainee, with his advisor, will select learning units at four different stages.

UNIVERSITY OF PITTSBURGH MODEL

SEQUENCE AND STRUCTURE

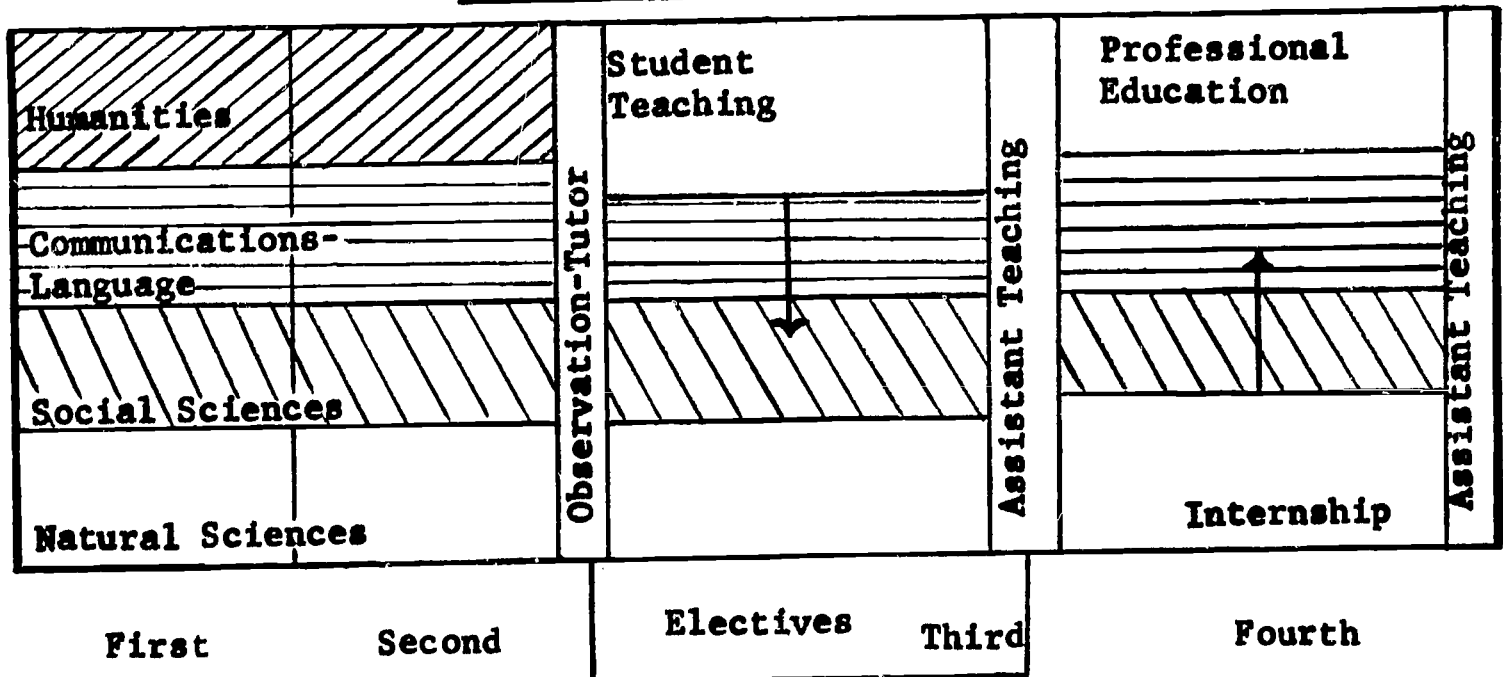

Figure 15. Sequential Progress of Trainee B.A. Education

Another facet of this model pertains to the instructional mode. This plan does endorse a strategy for teaching which could be used at all levels of learning. The diagram which follows contains the general plan:

- 1) Specify learning goals,
- 2) Assess,
- 3) Diagnose,
- 4) Plan,
- 5) Guide,
- and 6) Evaluate.

Many elements of this illustration could be developed more elaborately without violating the basic design. The following schematic illustrates this point:

UNIVERSITY OF PITTSBURGH MODEL

GENERAL INSTRUCTIONAL MODE

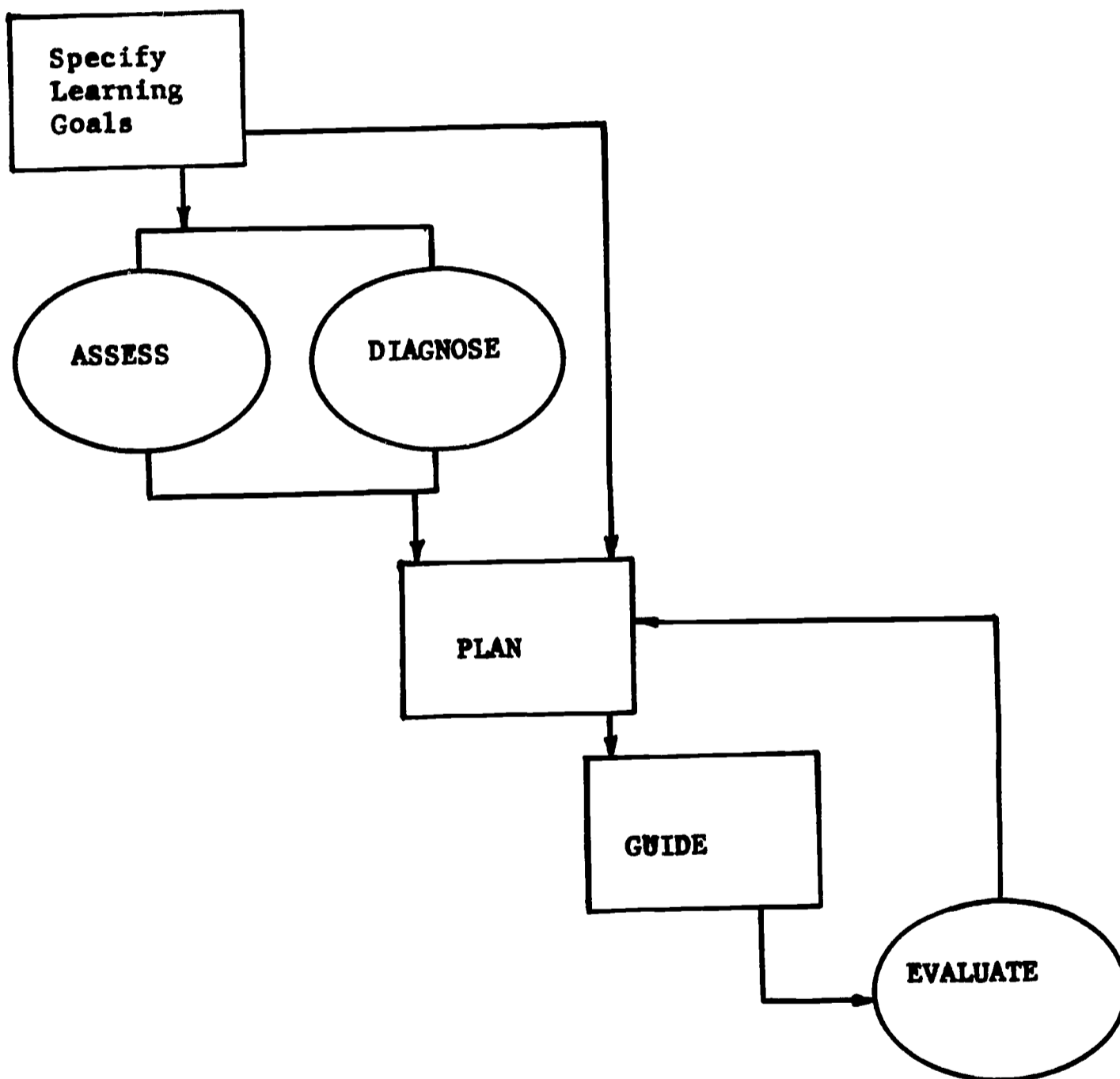

Figure 16. GENERAL INSTRUCTIONAL MODE TO BE USED BY ALL WHO PARTICIPATE IN TRAINING TEACHERS

**UNIVERSITY OF PITTSBURGH MODEL
 MATHEMATICS EDUCATION FOR ELEMENTARY TEACHERS
 LEARNING MODULE ***

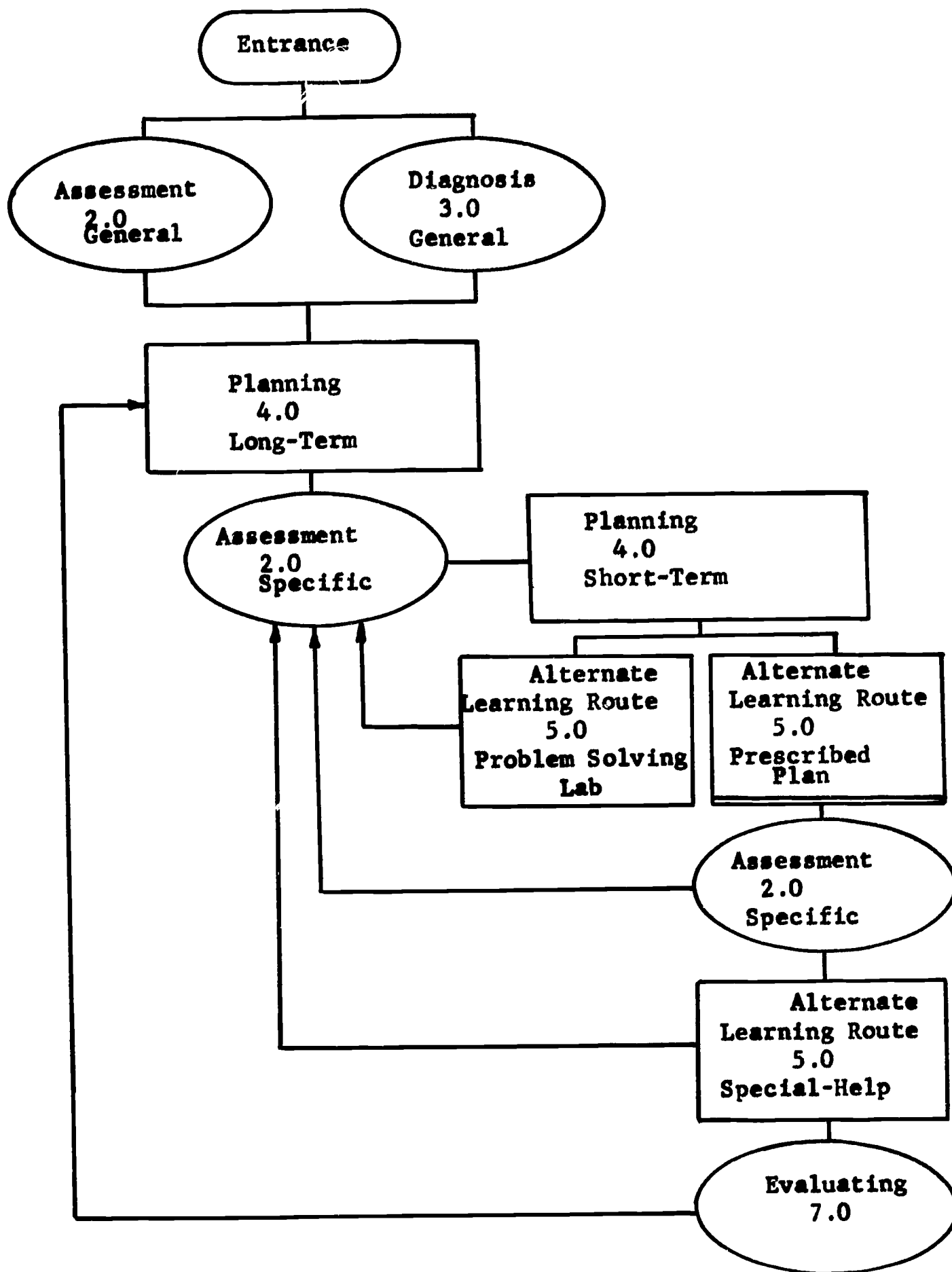

Figure No. 17. General Teaching Mode for Mathematics Education.

***See Appendix for additional information.**

Description of the Requirements of Teacher Training

The liberal education of the teacher trainee rests on a broad survey foundation in the liberal arts. For purposes of dialogue about this model the authors group Academic Disciplines into four areas; the humanities, communication and language, social sciences, and the natural sciences. The general survey nature has been governed or conditioned in the past by the amount of time for study in a four year curriculum and the self-contained organization pattern which predominates in the American elementary school. The flexibility of the Pittsburgh Model will permit the trainee to acquire different experiences more easily at his own pace, based upon mastery. Further, the implementation of the instructional mode by professors at the university will provide many more alternate routes in pursuit of mastery in the liberal arts area. By systematically helping trainee's gain command of content structure, key concepts, principles, and modes of inquiry in a discipline, the very nature of liberal arts can become more relevant for future educators and all students.

The knowledge base for establishing a profession of teaching has its roots in the liberal arts with its focus upon inter-disciplinary relationships. The trainee must implement knowledge about curriculum, instruction and the learning process as particularly influenced by sociology, psychology, communication, and anthropology. Of paramount importance to teacher training programs is the extension of the knowledge base upon which teaching can become a profession. Knowledge of change processes, systems analysis, research methodology, teacher decision-making analysis, and formative and summative evaluation procedures are prerequisite to faculty implementation of the Pittsburgh Model for Individualization of Instruction.

For teacher training to move to a competency base it will mean a forclosure upon the accumulation of course credits, grades, semester hours within rigid semester organizational patterns. The successful application of knowledge with pupils in accepted instructional modes in the judgment of clinical faculty will be the criterion for certification in the future. The adoption of the basic instructional mode by the college instructor of liberal arts will permit the trainee to pre-test and posttest unit experiences at his own pace. Tests in this case will be more than paper and pencil in nature. A competency means the ability to know, understand, and demonstrate a specific task at or above an identified level of performance. Such concern about transfer of credit, and temporary certification would diminished or accommodated by competency capability.

The guidance of teacher trainee's should be predicated upon development of self-direction, awareness of self, and the skill in working professionally with children and colleagues. Through a varied pattern of relationships with faculty and peers, trainee's must overcome impersonalization, loneliness, feelings of powerlessness about affecting change, and dependence upon direction from authority. The confidence of self must stem from the expertise and mastery gained in training.

Clinical settings for training are required to link preservice and in-service programs for teachers. The clinical setting cannot be established without a new coalition between colleges, schools, teacher organizations, and state or federal agencies. The relationship between theory and practice can achieve some consistency when teacher training coalitions establish environments for training that truly represent the most explicit behavior models and techniques desired in pushing teaching to new levels of performance. In-service retraining of teachers must become a professional obligation of the school district, teacher organization, and the related agencies of government. It must be cast in closer proximity for solving solution of problem in education. A clinical setting must feature, service to children, training for teachers, and extension of the knowledge base for teaching. In the case of individualization of instruction, it must provide a curriculum and materials to support this philosophy of organization for learning.

The implementation of the Pittsburgh Model is considered in direct relationship to the requirements of teacher training and the general specifications for each component.

TABLE V THE UNIVERSITY OF PITTSBURGH'S FIVE REQUIREMENTS FOR TRAINING TEACHERS

<u>Requirements</u>	<u>Specifications</u>	<u>Implementations</u>
ACADEMIC EDUCATION	Communications	Mobilize departments for the study of individualized instruction
	Humanities	
	Social Sciences	Refinement of the instructional mode of the faculty
	Natural Sciences	Develop units of instructions
		Coordinate the above and offer to program

TABLE V: FIVE REQUIREMENTS FOR TRAINING TEACHERS (continued)

Requirements	Specifications	Implementations
PROFESSIONAL EDUCATION	Study of the problems that grow out of working with children	Mobilize department for the study of individualized instruction.
	Collecting data for extending the knowledge base	Refinement of the instructional mode of the faculty
	Collecting data for refining the model	Develop units of instruction
		Coordinate the above to the program
COMPETENCIES	Competencies 1 through 7 of Chapter II	Working through the instructional mode until the faculty demonstrates mastery of competencies 1-7
GUIDANCE	Clinical Team processing	Working through the instructional mode until the faculty demonstrates mastery of competencies 8 and 9
	Individual counseling	
	Group directing	
CLINICAL SETTING	Servicing children	Establish a strong coalition among school district, university teacher organization and state and federal agencies
	Training personnel	
	Extending the professional knowledge base	

ACADEMIC EDUCATION

The liberal arts specifications of communications, humanities, social sciences and natural science form the basis for most training institutions. In the Pittsburgh Model the specifications are utilized in an individualized program.

Beginning with the mobilizing of each department for individualization the liberal arts faculty will be retrained and new units of instructors will be developed before the program will be offered. Each liberal arts department must study the conditions for individualized instruction and a new faculty instructional mode should evolve.

PROFESSIONAL EDUCATION

The professional education requirements addresses itself to learning theories, child development, psychology, etc. i.e the study of the problems that grow out of working with children. The professional education requirements also deals with collecting data for 1) extending the knowledge base and 2) refining the model. As systems of data collecting are refined, extending the knowledge base and refining the model, provide the basis for evaluation, restructure and change.

The implementation of the professional education requirements follows the same procedure as that found in the liberal arts requirements.

COMPETENCIES

The competency specifications are: 1) specifying learning goals, 2) assessing pupil achievement of learning goals, 3) diagnosing learner characteristics, 4) planning long-term and short-term learning programs with pupils, 5) guiding pupils with their learning tasks, 6) directing off-task pupil behavior and 7) evaluating the learner. The conditions of each of the above competencies must be evident in both the faculty and the finished product - the pupil.

Implementing the competency requirement must involve the faculty working through the instructional mode until they demonstrate mastery. No university or training institution can hope to implement an individualized program until the faculty is able to perform in the manner they wish to train.

GUIDANCE

Clinical team process, individual counseling and group directing are the specifications for the Guidance requirement. These specifications require the trainee to have several methods of obtaining relevant feedback for self-realization, self-development and self-evaluation.

Utilizing the eighth and ninth competencies, 8) employing team work with colleagues and 9) enhancing self-development requires the same procedure of implementing as that found in competencies above and for the same reason.

CLINICAL SETTING

The specification surrounding the clinical requirements are ones of servicing, training and extending. Training personnel certainly is the first consideration for any training institution, however, servicing children is also a vital function and should not be overlooked. Extending the professional knowledge base is a direct outgrowth of a clinical setting and will aid in outlining new directions as well as new procedures.

The clinical setting requires a new form of cooperation - a new coalition. No longer can the university hope to train teachers without the full support and cooperation of school districts, teacher organizations, state and federal agencies. This new coalition is essential for the implementation of any program designed to train teachers.

The University of Pittsburgh's Model is an attempt to bring together all of the forces required to insure a sound and far reaching program to not only train future teachers but to provide help and guidance to in-service teachers as well.

STUDENT PROGRESS THROUGH THE MODEL

In general the model follows the basic procedures of most instructional models, i.e., trainees are exposed to an instructional process in order to change their behavior as indicated by the specific goals and objectives of the program. In particular, the Pittsburgh Model is unique in its commitment to assisting each teacher trainee in achieving a viable system of self-development. The admission and guidance components exemplify this concept by including a thorough process of induction, interaction and reflection for the trainee.

Also unique is the flexibility of the model which will permit and facilitate individual program designs for EACH trainee. The model provides an opportunity for the trainee to help select and determine the nature and extent of his training experience. These features represent a determined effort to design a program which will emphasize the individualization in learning.

Two other major differences which make this model unique from most other models of instruction are the criteria of mastery of efficiency. In relation to mastery, the trainee will be expected to work through an ordered set of objectives, in the most effective way, until he reaches a specified degree of competency. Then he moves on to another unit. In relation to efficiency, the program will be individualized in order to provide the most efficient progress for each trainee and for the conduct of the total teacher training program. Efficiency here means that a trainee will not have to work in areas where he already has mastery, that his progress in the program will be geared to his own rate of learning without the arbitrary time limits usually imposed by courses or credits in more conventional programs.

1. Process of Admission to Professional Education Program

The general criteria for admission to the Education program are the following: a) that the candidate enjoys success and multiple interests among the academic disciplines; b) that he presents evidence that he is interested in and somewhat successful in helping children and adults; c) that he utilizes the American language and communication patterns well; d) that he is self assured and confident; e) that he has good physical health; f) that his total life pattern represents broad interests; g) that he indicates open and acceptant attitudes plus understandings based on reliable

and valid knowledge of all peoples in this society; h) that he understands the specifications for the teacher training program and agrees to work toward mastery.

Since the potential of the candidate, and the nature of his initial attitudes and commitment, will be very important in the admission stages of this model, guidance begins with the review and summation of the trainee's proficiency through the academic disciplines and observation experiences. The following chart shows this process. Notice that the model's flexibility provides for both admission and exit of trainees in more than one area, according to demonstrated mastery of the academic and clinical experiences. Upon admission, the trainee is assigned to an adviser.

2. Guidance Procedures

The guidance function, as presently practiced, guides the trainee through course requirements, but it does not aid in self-development. In the new model, however, guidance facilitates a more personal involvement. This is shown in the three settings outlined below. The entire process is aimed toward self-development, both professional and personal.

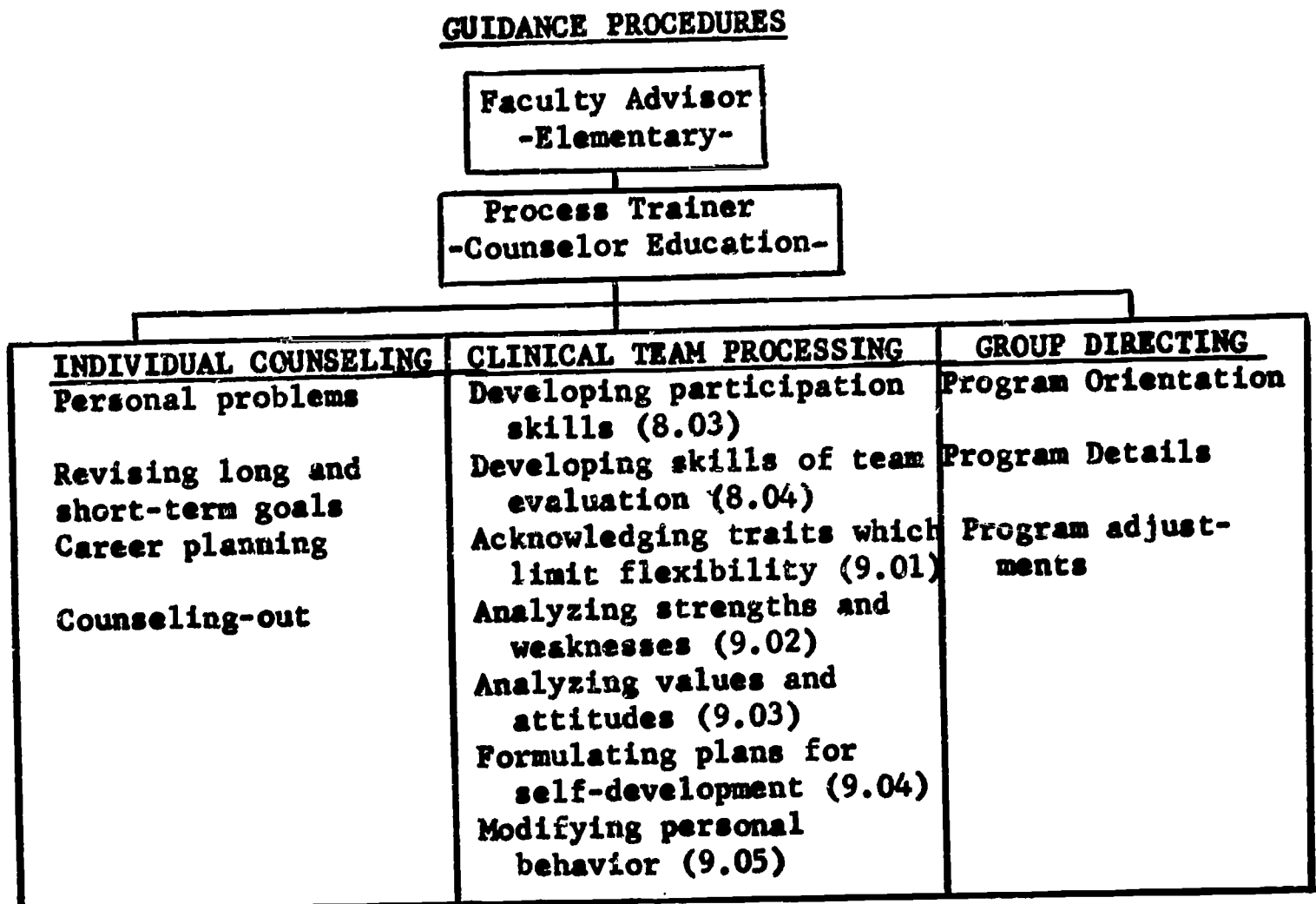

Figure No. 18. Guidance Procedures

ADMISSION TO PROFESSIONAL EDUCATION

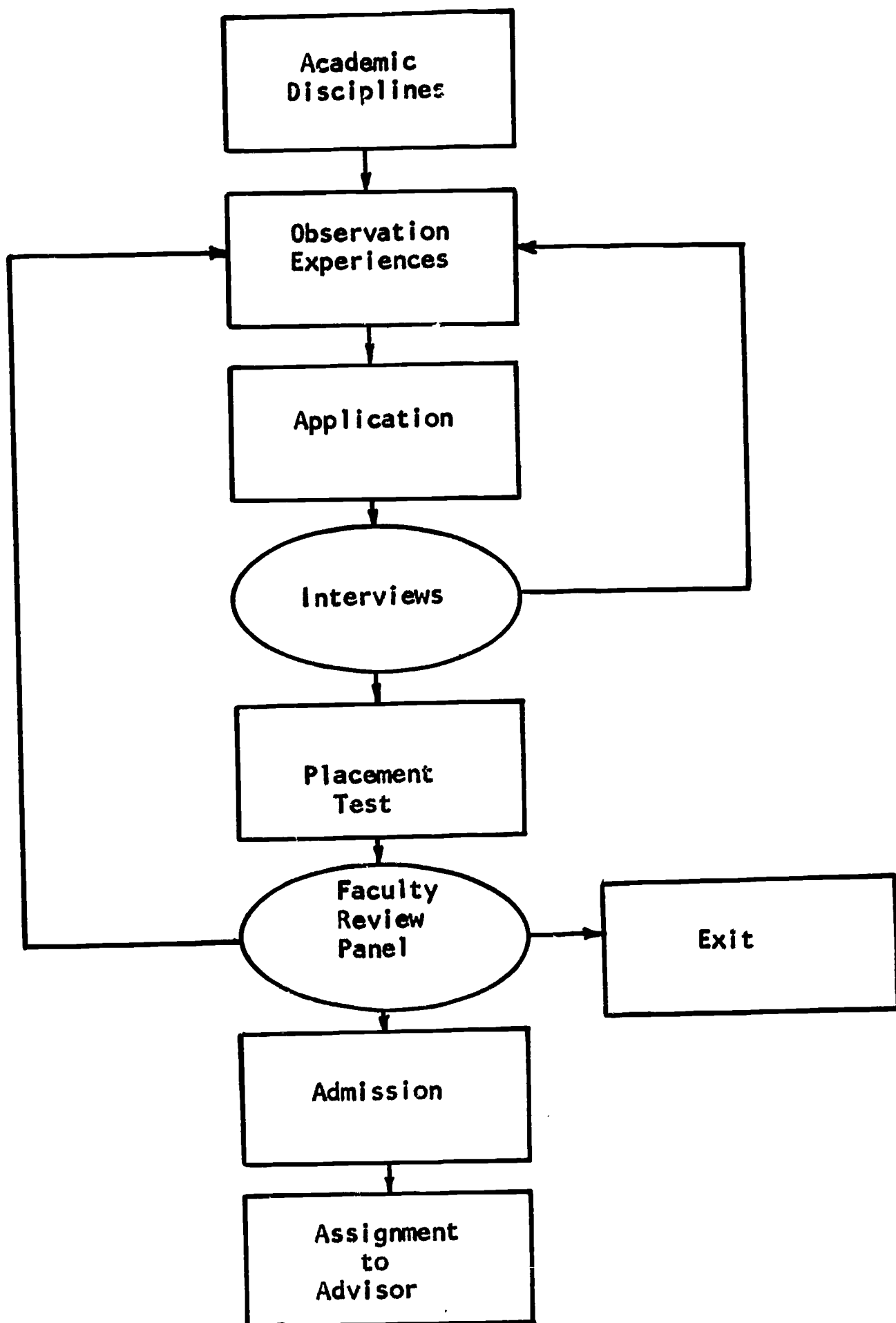

Figure No. 19. Shows Admission and Exit Procedures

With this emphasis on the individual, a trainee can expect to be a partner in determining his movement through the college program. No longer will a student be exposed only to the large lecture classroom organization. Peer group interaction, independent study, small seminar group sessions, and simulated modules of instruction will aid him through his college program.

3. Course Selection (Unit Experience)

The trainee will select courses (or learning units) at four different stages according to an ordered subset of learning units desired for fulfilling the requirements for B.A. in Education. This subset is selected either on the basis on long-term objectives, short-term objectives in that stage, performance in the previous stage and factors such as facilities available at school, requirements laid down by the school board and the individual.

The following chart and its sub-divisions present the total sequential movement of a teacher trainee through the four sequences of the new model, terminating at the B.S. in Education Degree at the completion of 32 learning units.

Below is a breakdown of the model sequence.

a. Academic Sequence - First Activities Series

The arrangement of this series offers the teacher trainee a continuous content resource in the Liberal Arts, Behavioral Sciences and Social Sciences.

With his advisor the trainee will select learning units in the academic disciplines as a result of personal assessment and placement tests and/or as a result of needs discovered by content tasks.

b. Clinical Sequence - Second, Third and Fourth Activities Series

During the second sequence, the trainee will be scheduled to observe and participate in the activities of the clinical setting. Data will be collected about his attitude, inter-relationships and successes as a tutor. The behavioral data and faculty judgment will form a part of the new basis for full admission into the training program.

INDIVIDUALIZED INSTRUCTION: LEARNING SEQUENCES (Hypothetical Plan)

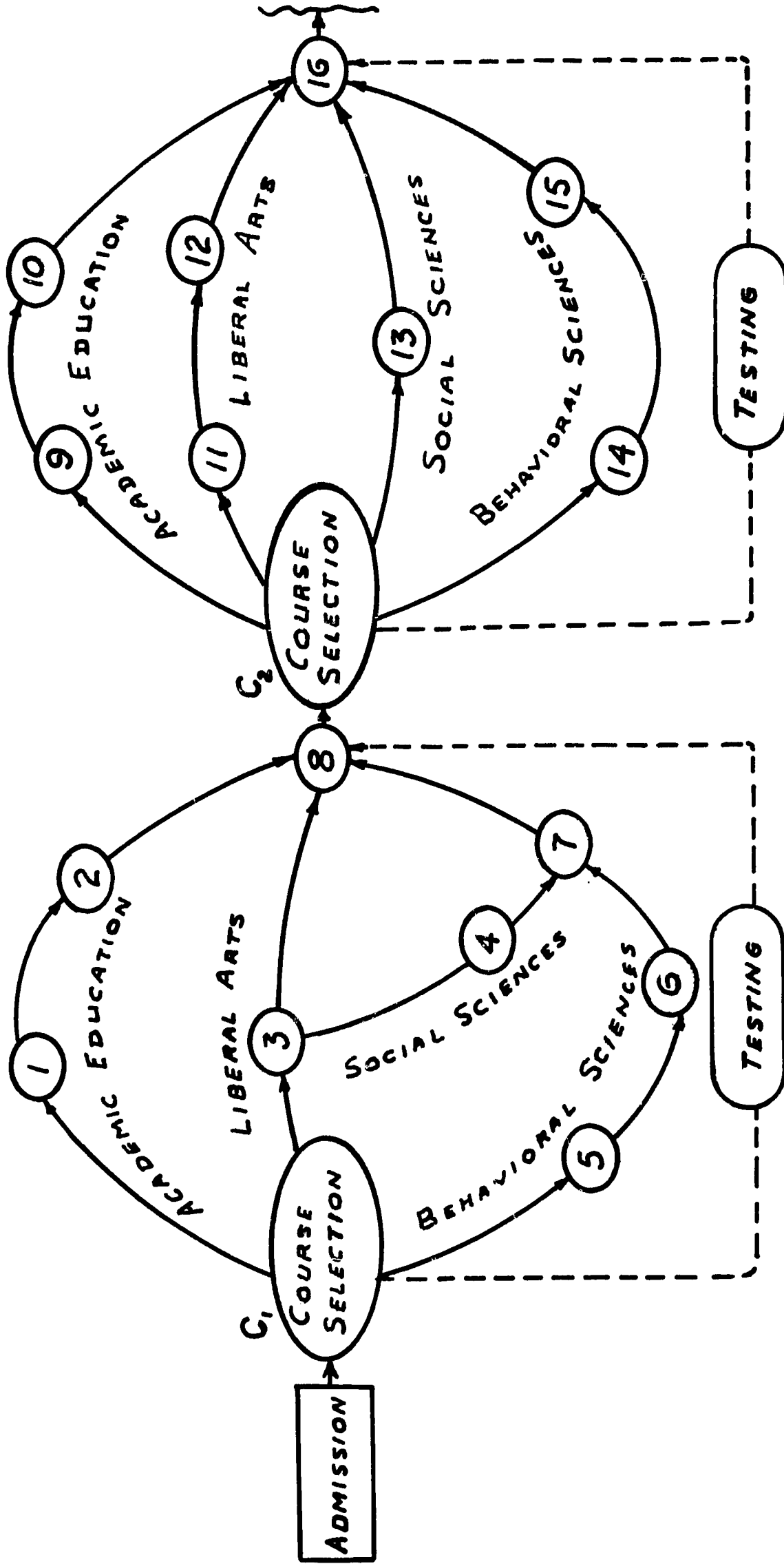

C₁, 2 - Academic Learning Sequences - tutorial, courses

C₃, 4 - Clinical Learning Sequences - tutorial, clinical

1, 2, ... 32 - Competency experience units needed for B. A. in Education

Figure No. 20. Total Sequential Movement of Trainee Through Program

INDIVIDUALIZED INSTRUCTION: LEARNING SEQUENCES (Hypothetical Plan)

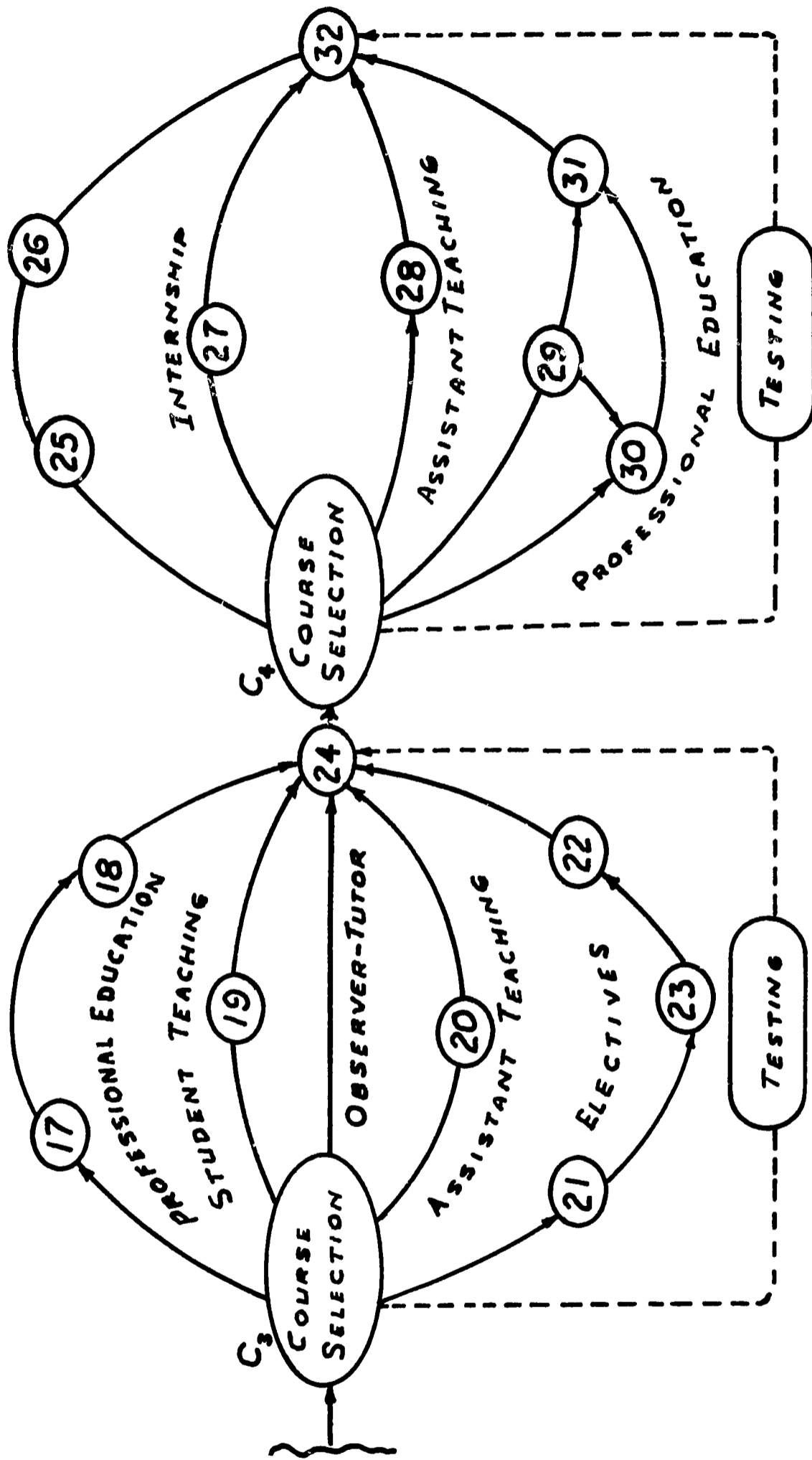

C1, 2 - Academic Learning Sequences - tutorial, courses

C3, 4 - Clinical Learning Sequences - tutorial, clinical

1, 2, ... 32 - Competency experience units needed for B. A. in Education

Figure No. 20. (continued)

The amount of time devoted to this segment of the program by the trainee is in direct relationship to his interests and faculty assessment. For instance, he could be trained for specific observation skills which would facilitate data collection to advance the base of knowledge about human behavior.

At the end of the trainee's second sequence he will make application for a student teaching experience. His entry will be based upon appraisals made by his advisor and other faculty members.

During the third sequence, the trainee will serve a dual role. He will be an assistant teacher part of the time and a student teacher part of the time.

As a student teacher 100% of the trainee's time will involve working with pupils for the purpose of observing his level of mastery in the competencies. He will function in a team situation supervised by clinical faculty members.

The trainee, in his role as assistant teacher, will be provided clerical experience, teacher aide experience and tutoring experience while rendering valuable service to the clinical team.

This type of experience provides continuous contact with pupils in both small and large groups, and in all phases of an elementary school program.

During the fourth sequence pupil contact will continue. Team membership and each individual role or function will be analyzed. At this stage it is safe to assume some trainees will be exhibiting a great deal of competency mastery suggesting some experience in a leadership role of team or group.

At the internship level of experience, curriculum decisions, communication with parents, and other responsibilities will be added to his accountability range. The internship will continue until the specified degrees of mastery are achieved.

Cognitive units in liberal arts and education will continue to be scheduled by the trainee and his advisor until mastery of all required teaching competencies; in this case 32 units of learning.

On the preceding diagram of Learning Sequences notice the variable achievement rates between individual activity units. This defines the model's criterial nature of achievement: mastery of a unit of competency, instead of the traditional time measurement. The trainee advances as soon as he masters one specified learning unit.

The following flow chart shows the competency-unit experience in detail. Twenty trainees all start toward the same specified learning goal, but they use different learning techniques and arrive at the goal at different times. Individualized instruction can be either independent study or group study.

Summing up the training so far, we have been concerned with adapting procedures for admission, guidance and course selecting to the individual. This implies the theme of the Pittsburgh Model - Individualized instruction.

Individualized instruction, as defined by our model, must satisfy the following criteria:

1. That trainees are able to proceed toward mastery of the instructional content at varying rates.
2. That each trainee can make regular progress toward mastery of the instructional content.
3. That the units of instruction be determined by the competencies.
4. That trainees are involved in learning which is wholly or partially self-directed and self-selected.
5. That trainees are able to play a major role in evaluating the quality, extent, and rapidity of their progress toward mastery of successive areas in the program.
6. That materials, techniques of instruction, and classroom setting (both university classroom and clinical settings) are available so that instruction can be adapted to the individual needs of the trainee.
7. That trainees are engaged in the learning process through active involvement including a) involvement in selecting particular units to be studied, b) involvement with pupils either through a laboratory or clinical setting, and c) involvement in the learning process through such media as video tapes of their own performance.

Group study, then, does not violate the individualized concept; in fact, awareness of self can be more easily achieved when studied in relationship to others in similar circumstances, competencies better observed and mastered when working in a group or clinical setting.

INDIVIDUALIZED INSTRUCTION COMPETENCY - UNIT EXPERIENCE

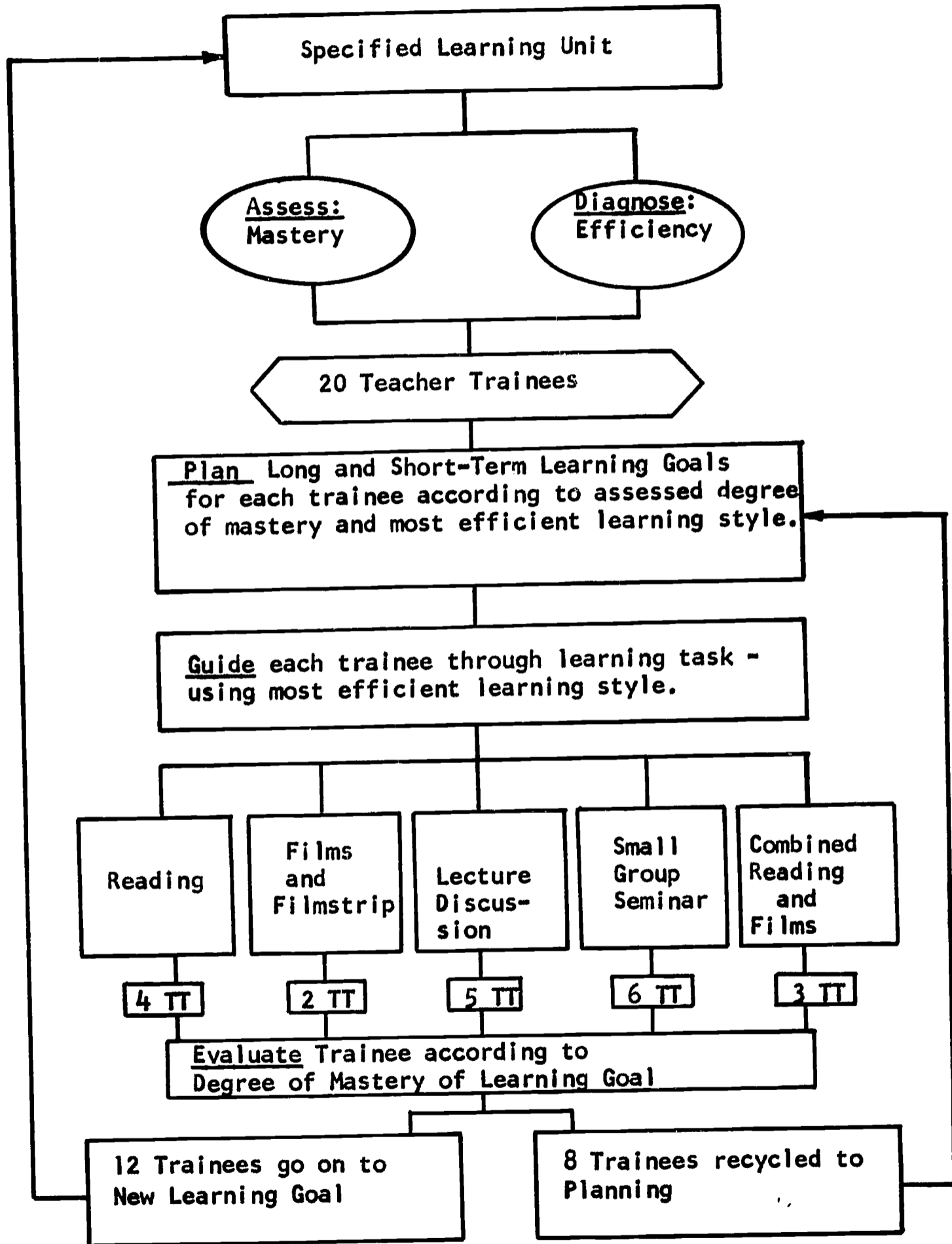

Figure No. 21. Competency-Unit Experience

Thus, the University of Pittsburgh Model is a flexible design. Its specifications are general. It is not complete in its present form. Even when implemented, it will need constant refinement, and change. However, the following aspects are cited to indicate how this model treats certain characteristics of individualized instruction.

Individualized instruction should be commonly practiced at the college and university level.

. . .This model proposes a general instructional mode for use at all levels of instruction.

Individualization should be practiced in a fashion that encourages every learner to be a planner, director, and assessor of his own education.

. . .This model includes a definition of teacher competencies necessary for individualizing instruction with attention to 1) specifying learning goals, 2) assessing pupil achievement, 3) diagnosing learner characteristics, 4) planning long-term and short-term programs with pupils, 5) helping pupils with their learning tasks, 6) directing off-task pupil behavior, 7) evaluating the learner, 8) employing teamwork, and 9) enhancing self-development.

Individualized instruction is a demanding pursuit which requires the talents and energies of the entire profession.

. . .This model proposes a new coalition which includes school districts, universities, teacher organizations, and state and federal agencies.

. . .This model proposes that professional staffs work in teams to meet the wide range of needs of learners.

. . .This model proposes that we learn to be effective team participants.

. . .This model proposes a new linkage between pre-service and in-service training such that in-service education becomes a part of the daily operation of the school.

Individualized instruction demands a new partnership between the pupil and teacher to accommodate the human variable in learning.

. . .This model proposes that each teacher trainee initiate a process of self-development as well as professional development.

1. Figure 22, shows the Gestalt or the total programs for training teachers for individualized instruction.

Individualization is a process demanding continual refinement.

. . .This model proposes a systematic feedback system of the training experience so that the process remains relevant to the needs of trainees.

2. Figure 23, shows the self-regenerating feedback system which affects all components.

Through decision analysis, each component is assessed and evaluated, not only for its own internal consistency, but for its interdisciplinary relationship and, also, for its relationship to the philosophy of the model itself.

The Philosophy of Individualization

The philosophy of individualization is one of change, and any institution bidding on this model should make this commitment. When this vital first step has been completed, the institution can proceed to the subsequent steps which result in total implementation.

3. Figure 24, shows this process of implementation by the bidding university.

The Estimated Cost of Individualization

Also of interest to the implementor is the probable budget necessary for individualization of instruction. Following is an estimated budget for implementation.

THE UNIVERSITY OF PITTSBURGH MODEL OF TEACHER TRAINING FOR THE
INDIVIDUALIZATION OF INSTRUCTION

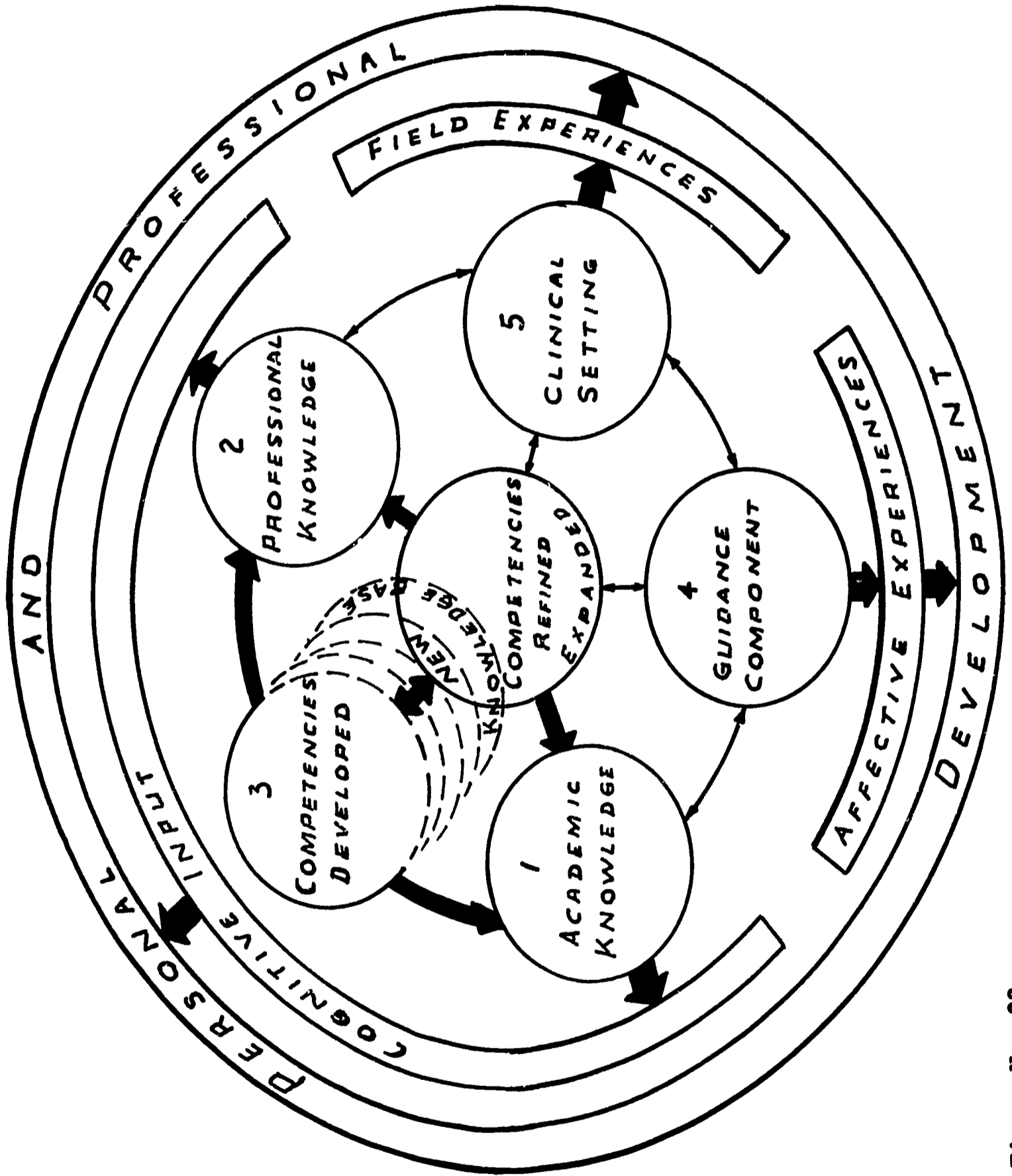

Figure No. 22.

GESTALT

UNIVERSITY OF PITTSBURGH
PROGRAM REGENERATION SYSTEM

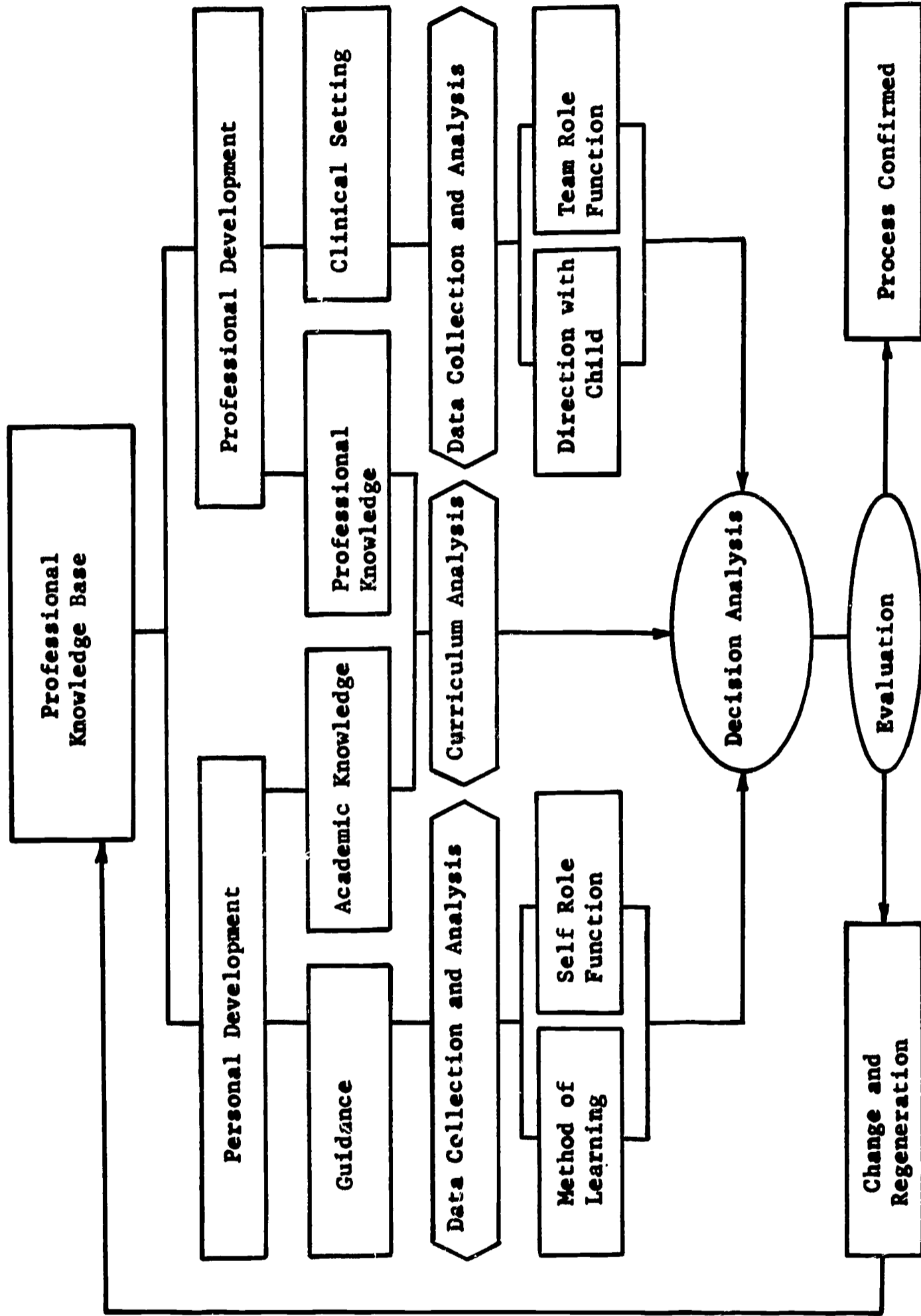
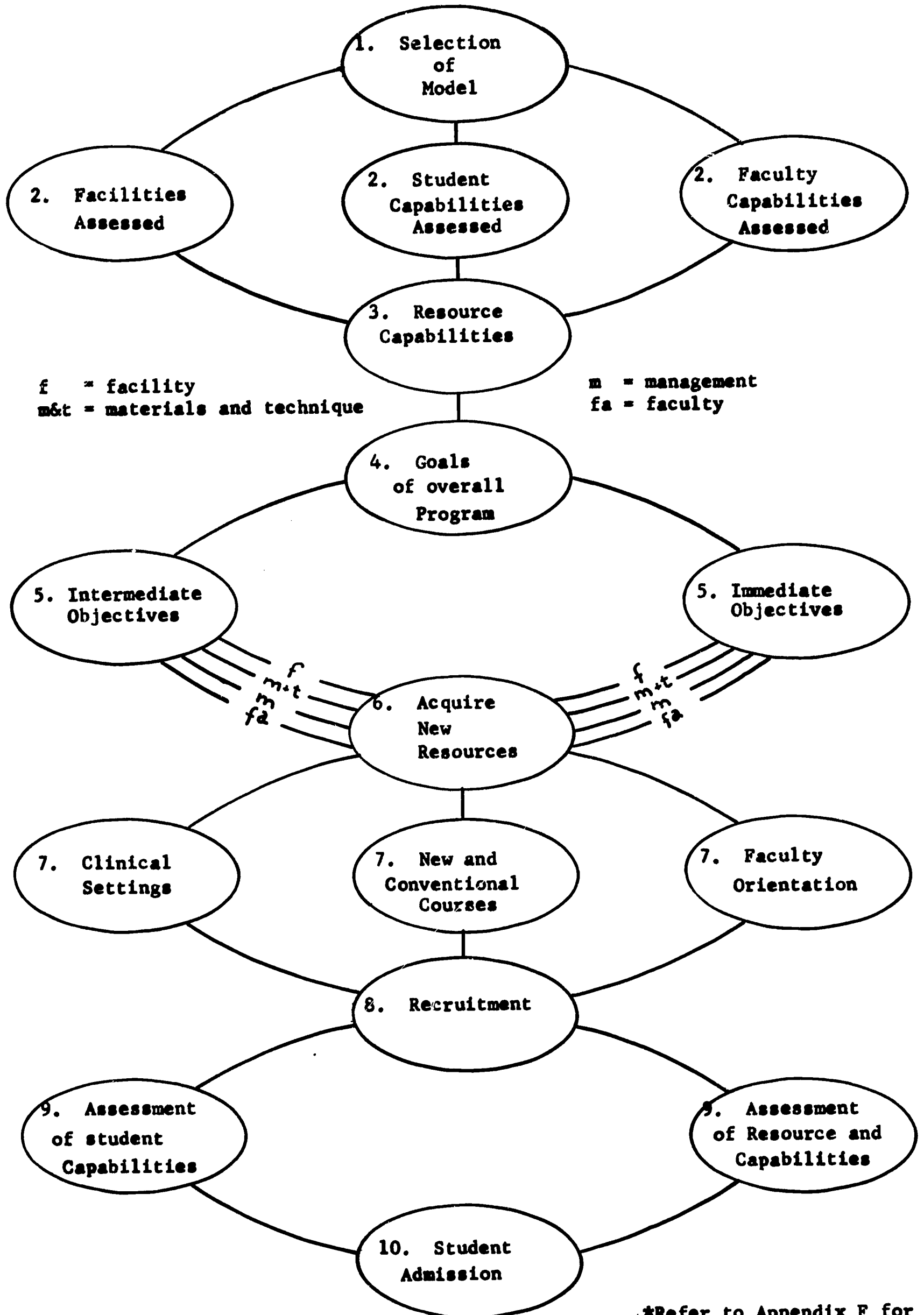

Figure No. 23. Program Regeneration System

Figure No. 24. University Implementation of the Pittsburgh Model. Sequence of Events



*Refer to Appendix F for Estimated Cost Analysis.

ESTIMATED COSTS OF UNIVERSITY IMPLEMENTATION

Rationale for Estimating Costs for Implementation

This budget approach is functional, based on the probable costs of operational units of the implementation process plus the space in which to conduct the operations. It is intended to supply a prospective user with information necessary to develop a budget appropriate for his local situation. The five major cost sources, functionally stated, are Administration and Coordination, Instructional Materials Development, Retraining Faculty, Space and Evaluation. All five can be expected to have high initial costs which will then taper off to maintenance levels. Since the full implementation of the model has not been attempted, the cost estimate below have not been validated and are subject to an uncertain degree of error. Therefore, it would be appropriate to make proper allowance for exchange of funds among functional units and to provide reasonably for contingencies.

1. Instructional Materials Development: Many specialized materials will be needed to implement individualization. Some materials can be bought and used almost "as is." Others can be adapted from commercially available items. Some must be created, all will involve cost, the last the most. Relatively little seems available for use "as is", perhaps 20% of what is needed. Another 70% could be adapted from commercial texts, films and other material, using programmers and unit writers to do the modification. That leaves 10% to be created, - that is, designed from scratch.

Instructional materials design and development and adaptation will probably account for the greatest single outlay of money in the first few years of implementation. The only hard basis for projections at hand is the cost for creating instructional materials in I.P.I. That, according to the Learning Research & Development Center staff, is \$3,000.00 per clock hour of elementary school instruction. We are assuming that figure applies also for the creation of materials for higher education. We are assuming, further, that modification and adaptation of commercial material for individualization will cost approximately \$500.00 per clock hour of instruction, and that "as is" material will need initial servicing to the extent of \$100.00 per instructional clock hour. The above estimates include both the development of the materials and their maintenance in operation with trainees during the tooling-up period.

Assuming approximately 1800 clock hours of instruction make up a four year collegiate program and that the goal is to individualize 1200 of those hours, the following costs can be estimated:

<u>Amount and Type of Material</u>	<u>Instructional Hours</u>		<u>Development Cost Per Hour</u>	<u>Cost Estimates</u>
20% (As is)	240	x	\$ 100.00 =	\$ 24,000.00
70% (Adapted)	840	x	500.00 =	420,000.00
10% (Created)	120	x	3,000.00 =	<u>360,000.00</u>
TOTAL				804,000.00

When all the individualized instructional materials are available for use, it is estimated that it will cost \$40.00 per instructional hour to maintain and replace materials as needed.

2. **Retraining Faculty:** Costs for released time and the tutelage of faculty in the use of individualized instruction calls for a large initial outlay and a continuing, tho' lesser, amount for a number of years. It will take on the average 20 hours of individualized instruction and supervision to equip a contemporary college faculty member to use individualized instruction at a satisfactory competency level in every-day teaching of college students. There will, of course, be a range of individual differences among faculty members, and the estimate allows for that. The cost per hour per faculty member is calculated at \$50.00, including released time, personnel and materials, or \$1,000.00 per faculty member for the initial 20 hours.

3. **Administration and Coordination:** The initiation of any activity of this complexity calls for a larger investment, at least for a time, in administration and coordination than does the conduct of a well-established program. This includes, for example, the development of the clinical component in the new way described in the specifications. Therefore, it is anticipated that one added professional person for every 50 students will be needed for the first two years, and one for every 100 students thereafter. The cost for one such person, including salary and benefits, space, facilities, secretarial support and travel is estimated at \$30,000.00 per year.

4. Space: It is assumed that relatively little change will be needed in the absolute amount of instructional space, on and off campus. Estimating the space increase needed on a per-student basis as 50 square feet to accommodate carrels, laboratories and other essential requirements, and calculating the space footage cost at \$5.00 per year, the per-student cost would be \$250.00 per year over and above present costs.

5. Evaluation: The nature and extent of the evaluation attempted will influence the cost, and that may vary markedly from one situation to another. Therefore, aside from noting that budgeting for evaluation is necessary, no specific estimates will be made here.

6. General Funding: Cost estimates need to be tested in practice. It should be possible, near the end of the first six months of an implementation project to estimate the next six with much more precision. And with the second six months added, the second year costs should be even more accurately predicted. If funding could be so designed as to take that approach it is likely that the efficiency and effectiveness of the project could be steadily improved, with a resultant favorable relationship between cost and quality.

BIBLIOGRAPHY

- Clymer, Theodore, "Curricular and Instruction Provisions for Individual Differences," 61st Yearbook of the NSSE, Part I, Individualizing Instruction, U. of Chicago Press, Chap. 14, 1962, pp. 265-286.
- Cohen, S. Alan, "Individualized Reading and Programmed Instruction," Programmed Instruction, 3(April 1964), pp. 3-6. ERIC.
- Combs, Arthur W., "Fostering Self-Direction," Educational Leadership, 23, No. 5, 373-376, February, 1966.
- Crescimbeni, Joseph and George Thomas, Individualizing Instruction in the Elementary School. New York: Random House, in press.
- Critchfield, Richard S., "Instructing the Individual in Creative Thinking," New Approaches to Individualizing Instruction, (A report of a conference on May 11, 1965, to mark the dedication of Ben D. Wood Hall, Educational Testing Service, Princeton, New Jersey), 13-25.
- Darrow, Helen F, and Virgil M. Howes, Approaches to Individualized Reading. New York: Appleton-Century-Crofts, Inc., 1960.
- Doll, Ronald, Editor. Individualized Instruction. Washington: Association for Supervision and Curriculum Development, 1964.
- Durrell, Donald D., ed., "Adapting Instruction to the Learning Needs of Children in the Intermediate Grades," Boston University Journal of Education, 1959, 142:1-78, December.
- Gardner, John, Excellence: "Can We be Equal and Excellent Too?", Harper-Row, New York, N.Y., 1961.
- Glaser, Robert, "The Design of Instruction," Chapter 9 in 65th Yearbook of the NSSE, Part II, pp. 215-242.
- Goodlad, John I., "Diagnosis and Prescription in Educational Practice," New Approaches to Individualizing Instruction. (A report of a conference on May 11, 1965, to mark the dedication of Ben D. Wood Hall, Educational Testing Service, Princeton, New Jersey), 27-37.
- Heathers, Glen, "Individualizing Instruction and Title III, ESEA," Catalyst for Change: A National Study of ESEA Title III (PACE), Washington, D.C.: U.S. Government Printing Office, April, 1967, pp. 177-200.

Hughes, James W., "Self-Evaluation in the Elementary School," Education Leadership, 1967, 24:344-7, January.

Jackson, Phillip W., "The Teacher and Individual Differences," 61st Yearbook of the NSSE, Part I, Individualizing Instruction, University of Chicago Press, 1962, Chapter V, pp. 75-90.

Krathwohl, David R., Bloom, Benjamin S., and Masis, Bertram B., Taxonomy of Educational Objectives, Handbook II: Affective Domain, p. 44.

Lindvall, C. M., and Bolvin, John O., "Programmed Instruction in the Schools: Individually Prescribed Instruction," 66th Yearbook of the National Society for the Study of Education, Part II, 1967, pp. 217-254,

Miles, Mathew B., Editor, Innovation in Education, New York: Teacher's College Press, Teacher's College, Columbia University, 1964, p. 635.

Moore, Omar Khayyam, "From Tools to Interactional Machines," New Approaches to Individualizing Instruction, (A report of a conference on May 11, 1965 to mark the dedication of Ben. D. Wood Hall, Educational Testing Service, Princeton, New Jersey), p. 5-12.

McKeegan, H. F., and Moore, J. W., "Mediating Individualized Instruction at Bucknell," Audiovisual Instruction, V. 12, May, 1967, pp. 467-468.

Scriven, Michael, "The Methodology of Evaluation," Perspectives of Curriculum Evaluation, R.E. Stake, editor, Chicago: Rand McNally and Co., 1967.

Shulman, L. S., "Seeking Styles and Individual Differences in Patterns of Inquiry," The School Review, 73:258-66, August, 1965.

Southworth, H. C., "Issues and Problems as Viewed by a Large, Multi-Purpose State University Located in a Small City in Establishing Off-Campus Student Teaching Operations," Partnership in Teacher Education, Joint Publication AACTE and AST, 1968, pp. 133-141.

Southworth, H. C., "Need: Revolution in Teacher Education," Pennsylvania School Journal, 117:6-8, Pennsylvania State Education Association, September, 1968.

Suppes, Patrick, "The Teacher and Computer-Assisted Instruction," National Education Association Journal. 56:15-17, February, 1967.

Weisgerber, Robert A., and Rahmlov, Harold F., "Individually Managed Learning," Audiovisual Instruction, 1968, V. 13, pp. 835-839, October.

Wolfson, Bernice J., "Individualizing Instruction," NEA Journal, 55:31-40, November, 1966.

GLOSSARY FOR UNIVERSITY OF PITTSBURGH MODEL

1. AFFECTIVE EXPERIENCE include exposure to or involvement in real settings which influence feelings, emotions and attitudes of teacher trainees.
2. CLINICAL - pertaining to the cycle of practitioner behaviors in which methodology is a body of hypotheses undergoing the constant test in practice and are thus submitted to evaluation in terms of the implications for refinement.
3. CLINICAL EDUCATION refers to those courses, unit experiences offered by the School of Education and cooperating school districts wherein (a) children and youth are being instructed, (b) personnel are being trained or re-trained, (c) research and curriculum development is occurring.
4. CLINICAL SETTING - an institutional setting in which teachers and/or administrators are deliberately engaging in a routine or series of routines designed to fulfill the conditions of the clinical behavior cycle.
5. CLINICAL TEAM refers to persons functioning in differentiated roles within the clinical environment. The team will vary in number according to the specified activity, but will include such roles as: university professor, university researcher, classroom teacher, intern teacher, student teacher, assistant teacher, teacher aide, clerk, volunteer tutor, and observer. There may be occasions when the building principal and selected other resource will be involved, i.e., the community agent, nurse, diagnostician.
6. COALITION is the arrangement between or among several agencies or institutions. It demands specificity of obligation, functions, and accountability.
7. COGNITIVE INPUT includes academic knowledge needed and understood to function effectively as a teacher trainee.
8. COMPETENCY is the demonstration by performance of specified behaviors at a level acceptable to the clinical faculty.
9. COMPONENT is a program feature addressed to meet a teacher training requirement.
10. CRITERION is the accepted evidence that a pupil or trainee has learned a task.

11. DECISION ANALYSIS is that analytic process which identifies a teacher decision in the classroom context and examines the resulting actions for patterns of evidence contributing to the base knowledge supporting the teaching profession.
12. EFFICIENCY refers to criteria of the most efficient style of learning for each trainee.
13. EXPERIENCE UNIT refers to a module of learning and instruction in support or required for achieving a degree of mastery in an important teacher competency area. It may entail courses or performance experiences in either academic or clinical or both.
14. FLEXIBILITY refers to involvement of trainee in design of his own program. This allows for different course work, styles or learning and rates of achievement.
15. GUIDANCE is developing a system for personal and professional growth through the function of clinical team process, individual counseling and group directing.
16. INDIVIDUALIZED INSTRUCTION consists of planning and conducting, with each pupil, programs of study and day-to-day lessons tailor-made to suit his characteristics as a learner.
17. IN-SERVICE is the retraining state or experiences necessary to maintain the mastery level for experienced teachers. To support individualization, large scale retraining would be necessary.
18. INSTRUCTIONAL MODE is a basic plan to restructure all teacher-learner experiences to include specifying goals, assessing student achievement, diagnosing learner characteristics, planning programs with students, guiding students, and evaluating student progress.
19. LEARNING ENVIRONMENT is the totality of experiences (in and out of school) which effect the particular pupil's learning. In the context of individualization, even when the focus is on the immediate goals of an instructional incident there is the assumption that the consequences of an instructional decision will be conditioned by the learner's total learning environment.
20. LEARNING GOAL is specified behavior or objective to be demonstrated by the pupil or trainee after participating in a planned and measurable activity.

21. LIBERAL ARTS STUDIES refers to those humanities, arts, and science courses or experience units which are offered by a school or college department linked with but not administered by the School of Education.
22. MASTERY is the level of performance or achievement specified as necessary to gain certification.
23. MODEL is defined as a design of strategies for reformulating teacher training in the direction of individualized instruction.
24. OBJECTIVES is development of a description of practitioner behavior as practiced in a given setting for the purposes of (1) stimulating a more introspective analysis of the practitioner's decision-making, (2) identifying dissonance with laboratory research, (3) selecting incidents for experimental change, and (4) providing meaningful information about teacher's decision-making behavior to suggest important laboratory research in human learning.
25. PHASE refers to a significant portion of the teacher trainee's individualized program. It does not necessarily coincide with the academic calendar, university organization or class status in the university degree program.
26. PROFESSIONAL KNOWLEDGE refers to those courses or experience units which form the base for establishing a profession of teaching.
27. PUPIL refers to the elementary child as distinguished from the student or trainee in the teacher training program.
28. RESEARCH is delimited here to knowledge (and procedures to get new knowledge) about human learning and instruction.
29. RESEARCH TRANSLATION is the process of getting what is known about human learning and instruction into the practice of teacher, administrators, and other decision-makers in the schools.
30. SELF-DEVELOPMENT is that process or system established by the trainee to appraise, interpret, and modify his objectives in the short or long range of his personal and professional growth.
31. TASK is that which the pupil or trainee is expected to achieve.
32. TEAM TEACHING is used to describe the training and retraining group in the clinical setting. Functions of instruction, role definition, and interrelationships among team members are requisite to the definition.

33. TERMINAL BEHAVIOR refers to behavior known to be in the teacher trainee's repertoire at the time the teacher is certified by the institution as having completed the period of preparation for initial licensure for professional practice. Terminal behavior is related to but not an exact synonym or equivalent of teacher competencies. Terminal behavior is evidence of teacher competencies.
34. TRAINEE refers to teacher candidate or student. The term trainee is used only to accommodate specifications of the U.S. Department of Education.

APPENDIX A.

PROCEDURE FOR ANALYZING A TASK OR COMPETENCY

Procedure for Analyzing a Task or Competency

An evaluation or analysis process has varied starting points. As stated in Chapter One, it can even have a societal starting point. Quite often we need only begin with an examination of a task we do, assuming its rationale is correct. We examine the task on the assumption we are doing it wrong, or we could do it more effectively or efficiently. As stated in Chapter One, our task was to reexamine and re-state the entire role of the teacher, shifting from a group methodology to an individualized methodology. Out of this assessment came a new 'set' of competencies.

In this section we will analyze the first competency category, (Specifying Learning Goals). (Note the internal consistency in this model: the competencies listed for the teacher trainee in the program are the same competencies the model bidder must gain.) We will treat this competency category as a course; that is, with a set of sequential experiences organized to demonstrate how the entire competency area can be taught. In this process it should be noted that competency areas are branch-prone; in developing one competency you branch into others.

In analyzing the first competency area, Specifying Learning Goals, we will use the following process:

- 1.0 What should be taught is examined from a cultural, societal, and philosophical view. (Are we meeting society's and children's needs? No. Then a whole new Model must be constructed.)
- 2.0 Who should do the deciding? (In this case, it is a professional group, not a citizen group.)
- 3.0 The new process or curriculum is categorized broadly. The examination of what should be taught is reduced to courses, packages, experience sets, curriculum, or set of competencies. (In our cases crucial knowledges and competencies.)
- 4.0 The package is assigned to an institution. Normally, assessment will specify which institution - home, church, school, does the teaching. (Ours is a university task.)
- 5.0 Members of that institution further categorize the learning into areas or types of learning; cognitive, affective, values, concepts, fact, information, skill, or process areas. (In this case we are dealing with concepts, knowledges, and skills.)

- 6.0 The specifications of the miniature properties of the learning are developed. (We will do this because we are offering this model as an example so that you may specify the properties of the other competency categories.)
- 7.0 The specifications of the characteristics of the learner are developed; the learning is assigned on a hierarchy of individual needs.

7.1 A competency can be regarded in many dimensions. It may be viewed as:

- 7.11 A specified terminal behavior
7.12 A remedial experience, or
7.13 A direction for depth or analysis.

If you are working with the educational aide role, the instructional performance is limited. The aide has the function of listening to children, i.e., getting feedback, and 'monitoring' the child in the learning task, (Pleasant smile: "No, that is not red. Try once more. Point to the red block.") making marks on paper concerning the child's performance in terms of printed criteria. Aides need only develop certain competencies and few need to be analyzed in depth.

A teacher might be examined on every competency; if he fails, he will be put to a series of remedial tasks underlying the competency or be 'guided back' through terminals that precede the final terminal. This would occur, for example, in student teaching. However, during internship, the teacher might be judged on how he performs the terminal behavior with 'style' or élan. Furthermore, the intern might be required to discuss the theory behind the terminal behavior competency. Still further, the trainee might trace a particular competency for re-evaluation. Institutions implementing the model will have the further obligation of stating learner characteristics, and fitting the learner to the specified learning task.

- 8.0 The specifications of the learning setting are developed.

Following is Competency Area One, Specifying Learning Goals, developed as a course, with experiences designated as developing terminal behaviors within the general competency area.

1. Competency Area One, Specifying Learning Goals

Applying the Behavior Analysis Approach to Goalsetting, Testing Diagnosing, and to Micro-Teaching Experience.

Broad Purposes of This Unit

Analyzing teaching behavior and designing an instructional program for teaching on the basis of the analysis.

In the process, training teachers to use simplified behavior and task analysis to plan and monitor their teaching.

To give the beginning teacher basic experience in pre-testing.

To begin to give trainee gross experience with children.

To enable the trainee to study individualized curriculum with understanding.

Specifications

- 1.1 The trainee will concentrate on the teaching of one child in a controlled, monitored, video-taped laboratory, adapting to and teaching only one child at a time.
- 1.2 Use PEP sensory, classification, mathematics, language, and gross motor skills curriculum.
- 1.3 Be given handouts that describe the goal setting-diagnostic phase; the teaching phase (which interacts continuously with diagnostic in practice). In this way the ability to do his own task analysis and, therefore, curriculum development will be developed.
 - 1.31 This is a chain, with numerous loops and branch points. We find the following teaching tasks, in gross:
 - 1.311 Deciding whether something needs teaching.
 - 1.312 Deciding what children need instruction in a particular skill.
 - 1.313 Doing task analysis and behavior analysis of the task. (Studying children for variables in response behavior will come later.)

- 1.314 Stating terminal behavior specification.
 - 1.315 Listing testing criteria and testing.
 - 1.316 Deciding whether or not child has responded correctly (including tests to make sure response isn't right for wrong reasons, and the necessity for adequately sampling behavior). These relate to task analysis, as the sub-terminals must be clearly in mind.
 - 1.317 Probing process, when child does not respond correctly. Asking appropriate questions and making appropriate adjustment. (Relates to a repertoire of teaching strategies.)
 - 1.318 Diagnosing and prescribing.
 - 1.319 Deciding on teaching strategies.
- 1.4 The real teaching problem is doing all these things smoothly, effectively, and "on the spot." Thus, there is no substitute for actually working with a child, and this is intended as the beginning part of the teacher training program.

There can be preparation for this interaction so that some skill in making discriminations is built up in advance, and there is at least a verbal repertoire of teaching behaviors and strategies available. Instructors sometimes videotape tutorial sessions, which are stopped at a critical point. Then, the student must decide what the source of difficulty is; or, for teaching a task, if there is any difficulty. For this, trainee must have available the same set of preparatory materials that the teacher has going into the tutorial session: i.e. terminals, (task and behavior analysis), and description of teaching strategies. By using these in early stages of training, trainee is being prepared for later stages where he will have to produce these documents. Some of this may be done through written or taped scripts prior to analyzing tapes of others, and prior to being videotaped and analyzing yourself.

- 1.5 Trainee works with children on the same tasks as he or she has read or seen on film, doing diagnosis, teaching and probing. He has documents (tests, terminal specifications, etc.,) available.

- 1.6 Trainee works with children on new tasks, still with documents provided.
- 1.7 Trainee decides on teaching strategies, given terminal behaviors resulting from task analysis. For some of these, he actually works with children.
- 1.8 Trainee now does task analysis, given random or terminal behavior. Through simulation, he gradually learns how to sequentially set goals by deducing previous terminals.
- 1.9 Trainee designs an entire teaching sequence, beginning with terminal behavior specifications, and on through rest of chain. Following is a gross motor skill from which to start.
 - 1.91 Recommended - Gross Motor Skill - (learning to hop).
 - 1.912 Compares own curriculum with provided documents.
- 1.10 Trainee applies his specifications to child in testing situation, developing criteria and testing language.
- 1.11 Practice in mirror the physical behaviors of testing: Controlling use of words in motivation session, direction giving and response; voice pitch, range, inflection, and emphasis of silence; facial expressions, such as warning glance, smile, raised eyebrows, stare, or "looks" of disgust or happiness; and assorted hand, head, or body movements that would influence the response.
- 1.12 Trainee samples across various kinds of teaching problems: concepts, motor skills, verbal chains, etc., with various age groups and types of learning histories.
- 1.13 Generalization to classroom final paper. Two questions:
 - 1) How would you adapt to more than one child at a time?
 - 2) How can you administer and manage a classroom to provide as much individual or very small group instruction as possible? Teachers trained in this way will favor individualized instruction and will work hard to arrange things so they can do it -- something which is not now the case.
- 1.14 Assess video tapes of micro-testing and teaching.

- 1.141 Additional notes: A child is pre-tested when the teacher thinks he can pass the pre-test. This means the teacher must be constantly trying for feedback in the classroom. Questions: Does the child tell you he is ready? Do you or the aide watch him? Here is another viewpoint:
- 1.142 Think of the pre-test serving as a goal setter. If the child does not pass the test, he knows where he is going and knows what to do, and knows what he has to learn.
- 1.143 Keep testing interaction to a minimum.
- 1.144 Don't teach during the test. If the child doesn't know the difference between long and short, one can point it out and see if there is immediate retention. You can then try to complete the task.
- 1.145 Going along with current descriptions of intelligence, try to foster independence, and after testing, give the child directions, and materials, and/or tell him he can get information from parents, peers, work. Wean him from his dependence on adults as the information source.
- 1.146 Wait for feedback from him.
- 1.147 Passing the post-test should now be an exciting process. If he does not pass it, treat it as a pre-test. (The child may deliberately not learn in order to get your attention. If this is the case you may have to set up a unique incentive system.)
- 1.15 Trainee does extensive study of I.P.I. and P.E.P. curriculum keeping a focus on language and conceptual development of ghetto children. For example: the development of discrimination as a building block for intelligence by considering memory skills, visual analysis skills, and problem solving skills, and how simple counting is basic to progress in mathematics skill sequencing. Trainee passes extremely comprehensive tests on this.

1.151 The accompanying task analysis chart identifies a number of interrelated behaviors required of the skilled teacher of reading. According to this analysis, a student's training as a reading teacher ought to begin with work in the specification and analysis of reading objectives (Behaviors A, B & C). This would be mainly via classroom discussions and assignments using university library facilities. With this work as a basis the student would be ready to profit from detailed study of the process of diagnosis in reading (Behaviors D, E, F). Some of this study might take place in a classroom setting (using case-studies, etc.). However, teaching "laboratories" in which students are able to work with children in a protected setting and, are able to observe their own performance for the purpose of self-improvement will almost certainly be necessary if diagnostic behaviors rather than theories are to be learned.

Development of teaching skills (Behavior G) should follow the work on diagnosis. This is because all teaching that is adaptive to the learner necessarily involves frequent, nearly continuous, diagnosis. In short, diagnosis is a component of teaching, which is a far more complex behavior, involving a large number of subskills. Some of these sub-skills are shown on the behavior analysis chart (Behaviors K-R). These skills are not specific to the teaching of reading, but apply to all teaching behavior. Actually, reference could be made here to virtually all of the competencies listed in the preceding sections 5.0 through 9.0 of II, A. The specific range of teaching procedures shown in the chart (Behaviors I, K, L, M, N, O) were chosen mainly to emphasize that "providing instruction" (Behavior G) does not necessarily mean standing in front of a class and talking, but organizing and managing all of the educational resources available.

Ideally, the student's work in these general teaching skills would take place before he was confronted with the task of teaching reading. Some of this work can take place in the university classroom, but well-structured observational and teaching laboratory experiences will undoubtedly be necessary to turn theory into usable skills.

Figure No. 25

PROCEDURE FOR ANALYZING A TASK OR COMPETENCY

Competency 1.0

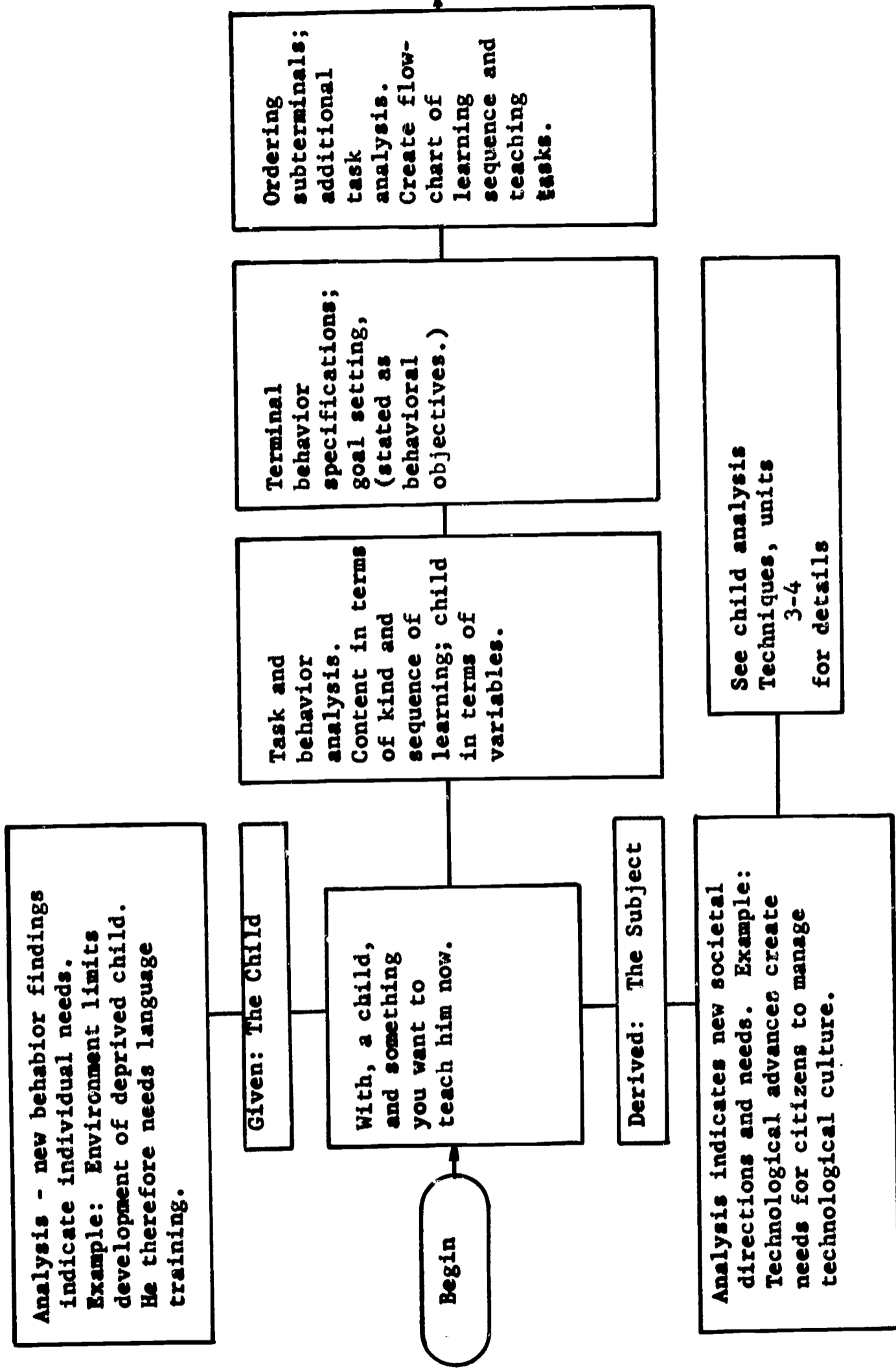

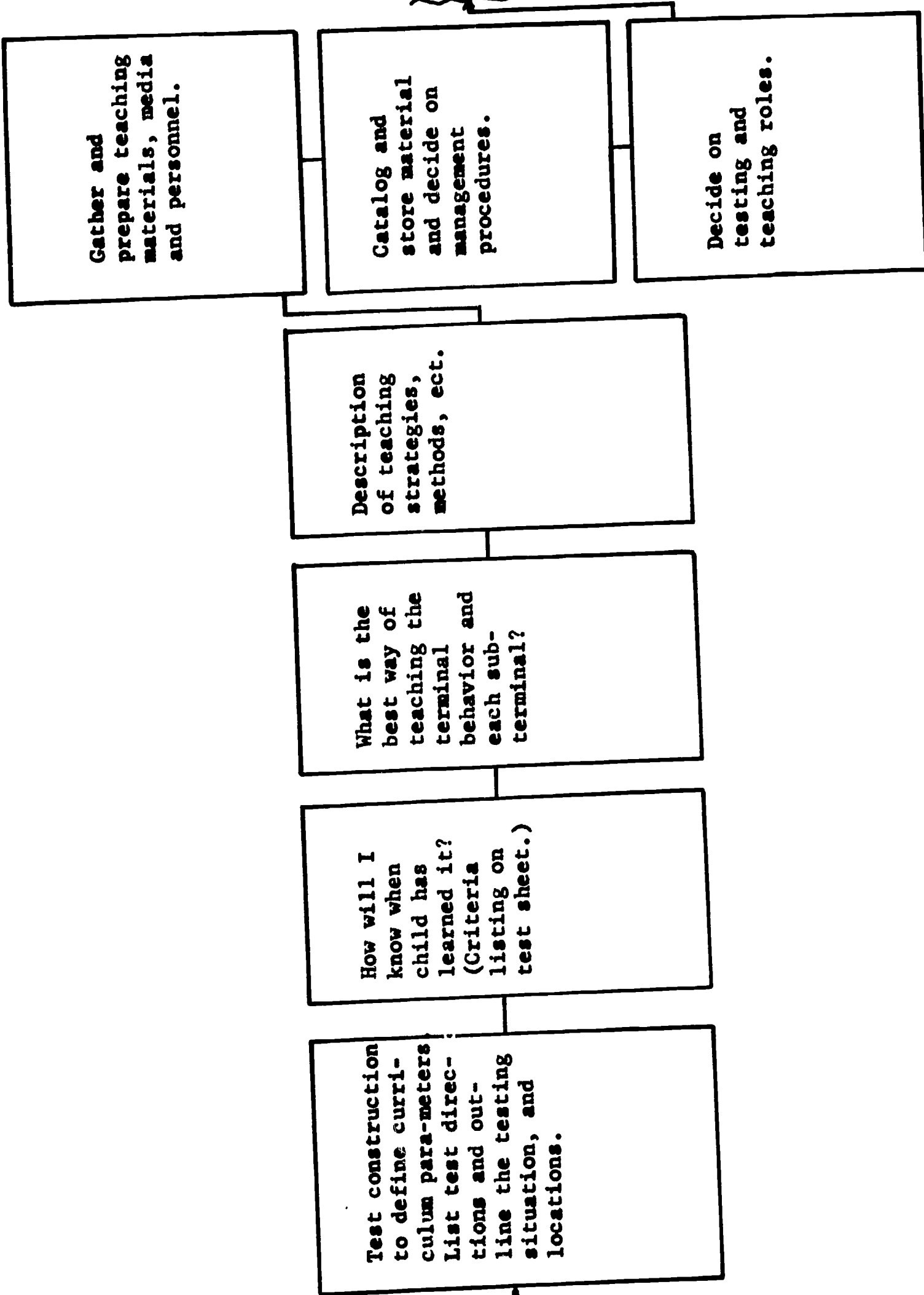

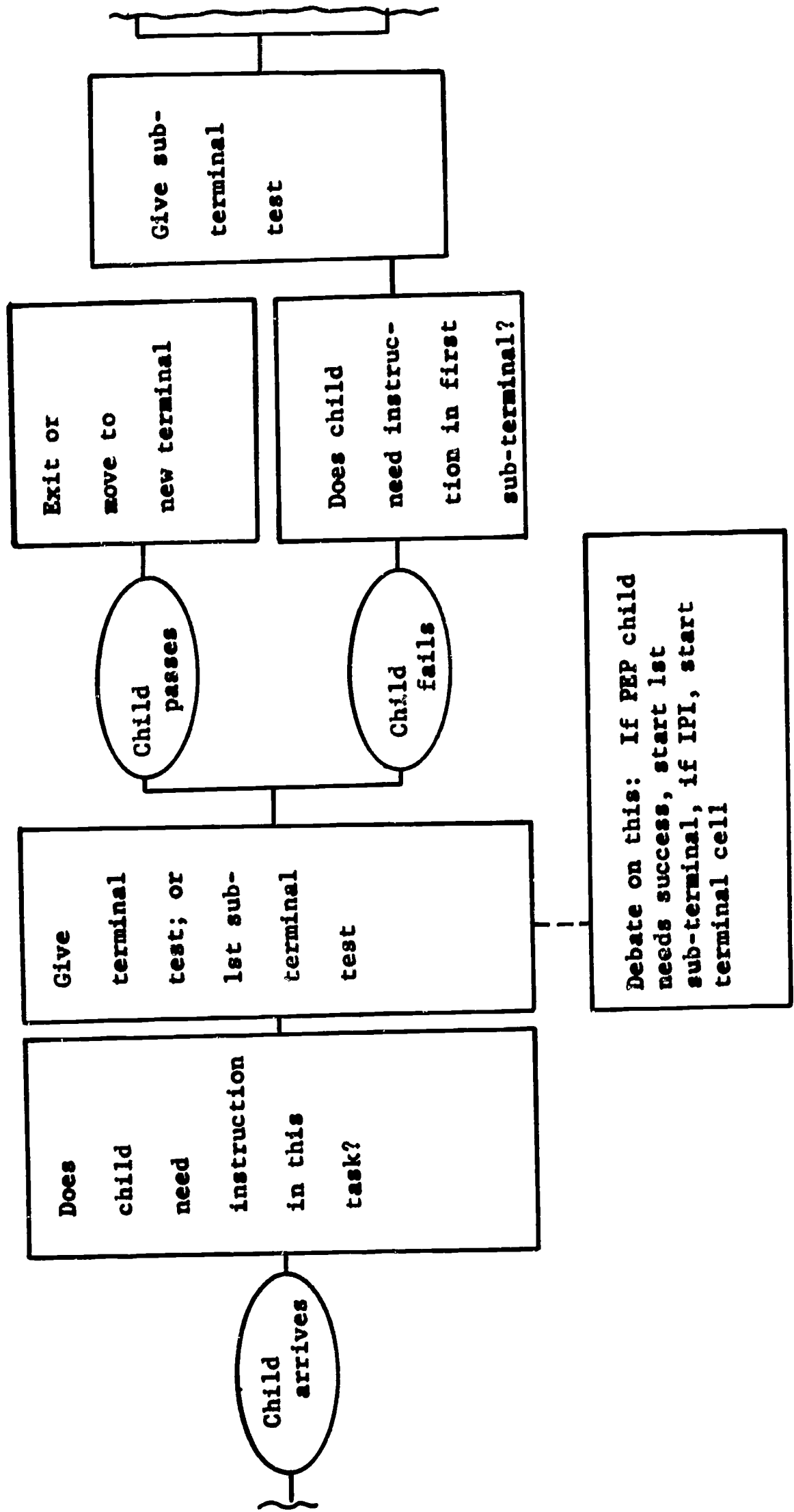

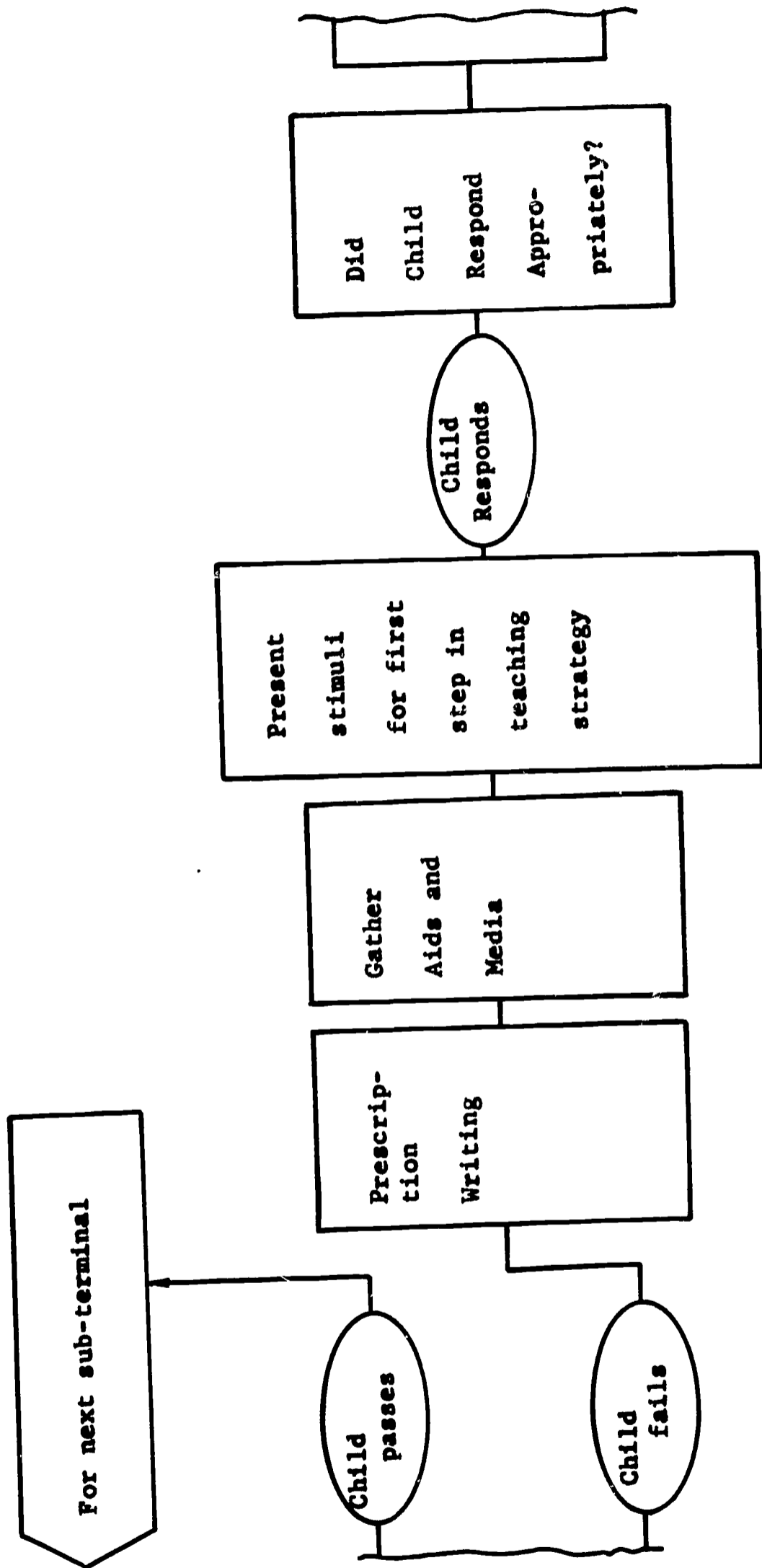

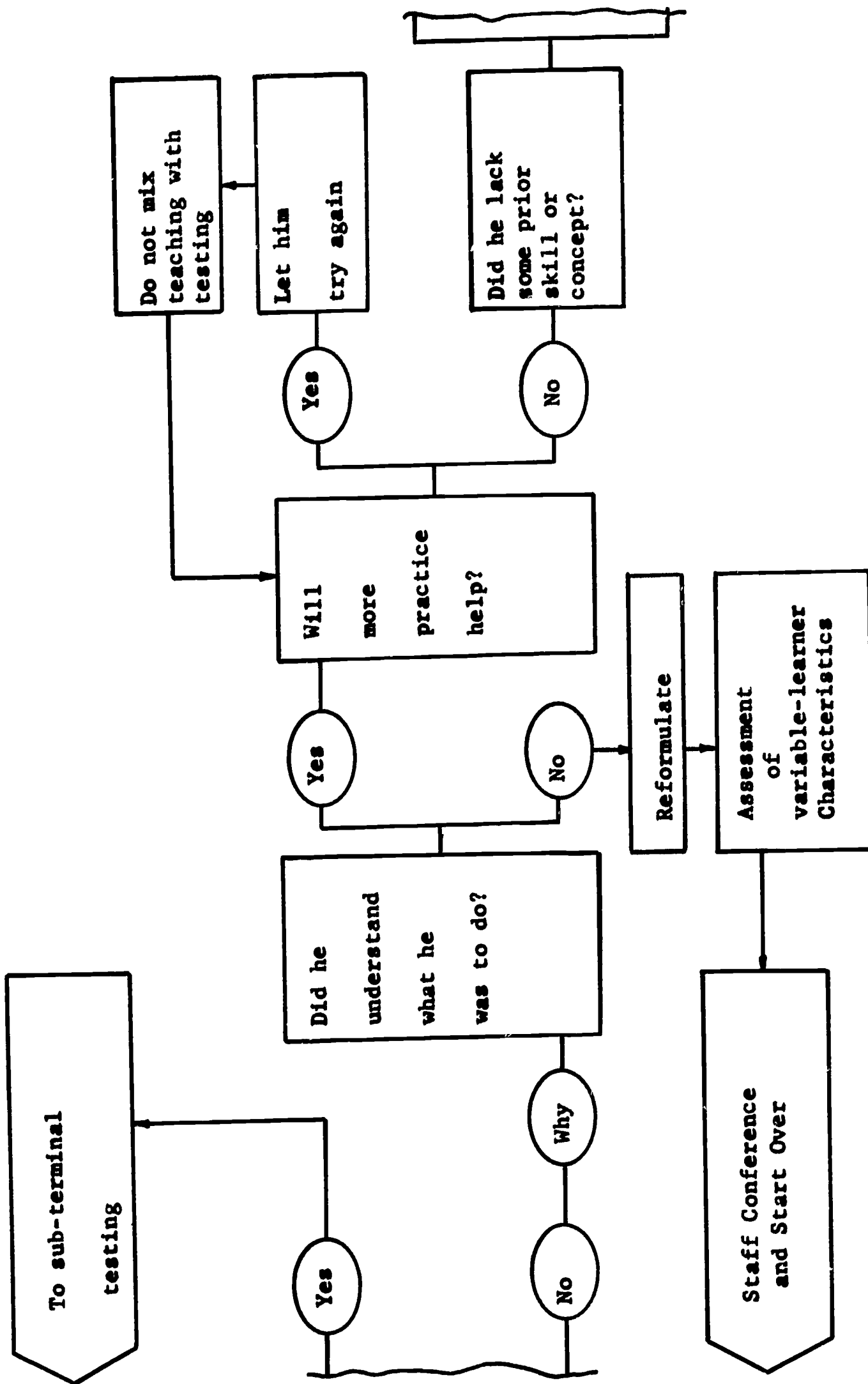

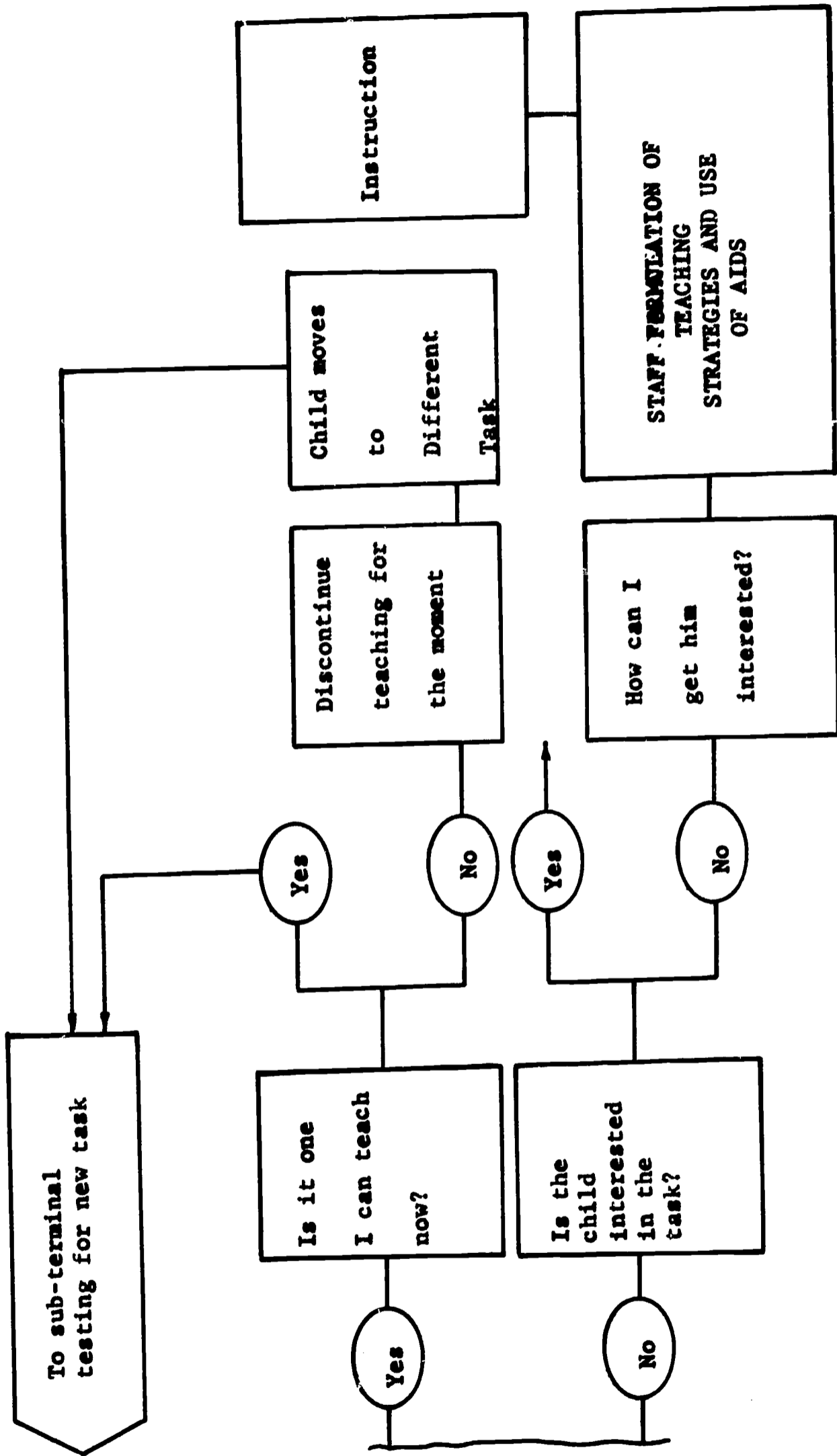

The behavior analysis suggests that work in constructing instructional materials (Behavior J) should come at the end of the student's work in reading. A prerequisite for constructing materials is selecting them intelligently (I), and this in turn requires the ability to diagnose pupil's specific needs (F). The ability to analyze and evaluate different approaches to reading instruction (H) is a prerequisite to selecting materials and depends in turn on the student's ability to specify and analyze reading objectives (B & C). At this final stage of training a return to the university classroom is appropriate. The student will bring to discussions and written assignments considerable observational and laboratory experience which can be effectively organized and integrated in the course of analyzing, comparing and eventually constructing materials for reading instruction.

1.152 Task Analysis of Teaching Early Reading: Description of Behaviors

The student can take reading course concurrently with the goal setting unit.

The teacher can:

- A. Describe phonetic, semantic, and syntactic characteristics of texts to be read at a given level.
- B. Behaviorally define the terminal objectives for a given "level" of reading instruction.
- C. For a given terminal behavior (and a given approach to reading instruction) state or identify component and prerequisite skills which the child must acquire).
- D. Construct diagnostic instruments.
- E. Administer and interpret standardized diagnostic tests.
- F. Diagnose a child's specific instructional needs in reading and make an appropriate assignment.
- G. Given appropriate materials, provide instruction in each skill involved in the reading process.
- H. Analyze different approaches to reading instruction and compare their strengths and weaknesses.

- I. Select appropriate instructional and supporting materials for reading instruction for a particular child or class.
- J. Construct appropriate instructional materials for reading instruction.
- K. Direct the instructional work of a classroom assistant or aide.
- L. Tutor an individual child.
- M. Establish and maintain classroom patterns in which children instruct each other, formally or informally.
- N. Assign and supervise self-instructional programs and games.
- O. Instruct small groups of children.
- P. Develop and maintain motivation for reading.
- Q. "Manage" a classroom in which children are engaged in a variety of different activities at a single time.
- R. Specify reinforcers (both intrinsic and extrinsic) available in the classroom and plan a classroom environment in which children are rewarded for learning activities.

The terminal behaviors which will be required of the student in the teacher training program have been listed. Task analysis in this unit refers to stating prerequisite behaviors which precede a competency listing, learning activities which will teach the competency, establishing criteria which will be useful as a basis for judging the competency, and the pre-test situation.

APPENDIX B
DIRECTING OFF-TASK PUPIL BEHAVIOR

41

PROCEDURE FOR TASK ANALYZING COMPETENCY AREA 6.0

Category six is Directing Off-Task Pupil Behavior. As stated, that is the terminal behavior that will be required of the teacher trainee in the teacher education program.

By task analysis, we mean stating the prerequisite behaviors (or competencies) that precede this competency area, i.e., a listing of learning activities that will 'teach' the competency, the criteria that will be used as a basis for judging if the competency is learned, (or in the case in teacher education, the 'team' that will observe the candidate's performance and make an objective decision), and in some cases, the pretest situation.

Most of the competencies involved in teacher education are those that must be 'acted out.' A Behavioral Objective usually encompasses behavior such as 'making a mark' on a test question; but in teacher education, many performance behaviors are not pencil and paper; but classroom performance in nature. That means that a 'supervising teacher' or guidance team must assess the behavior. Our current point of media development is inadequate to meet the demands of that kind behavioral statements and that kind of criteria direction.

6.0. Directing Off-Task Pupil Behavior

6.01 The teacher can describe different approaches to behavior control.

Prerequisites: Competencies 1.0, 2.0, 3.0, 4.0 and 5.0, academic studies and the professional knowledge bases.

	ACTIVITIES	CRITERIA
6.011	Lists all conceivable learning environment.	Judgment of List by team of advisors.
6.012	Describes permissive, autocratic, Laissez-Faire, and cooperative environments; as example, 6.0122 Relates with Theories.	Judgment of descriptions by team of advisors.
6.013	Creates critical incidents descriptive of listed environments.	Peers act out incidents and make judgments.
6.014	Views classroom environments on simulator and classifies them.	Instructor judges classifications.
6.015	Lists factors present in typical environments.	Instructor judges factors.
6.016	Hypothesizes about personality traits of teachers who choose particular environments.	Tests own hypotheses
6.017	Chooses an approach best suited for a particular learning goal.	Instructor judges appropriateness of environment and goal.
6.018	Chooses an approach best suited for a particular group of children.	Supervising teacher evaluates effectiveness of approach
6.019	Reads such texts as <u>Behavior and Misbehavior</u> , J. Hymes, Prentice-Hall; and <u>Summerhill</u> , as example.	Passes written test on text in question

6.0 Directing Off-Task Pupil Behavior (Cont.)

6.02 The teacher can involve pupils in deciding on acceptable pupil conduct.

Prerequisites: Competencies 1.0, 2.0, 3.0, 4.0 and 5.0.
Academic and Professional Knowledge Bases.

	ACTIVITIES	CRITERIA
6.021	Creates an environment of pupil participation in student teaching or aide work; as examples,	Judgment of supervising teacher.
	6.0211 When planning a unit in social studies allows for opportunities for children to work in major area of interest.	
	6.0212 When guiding an individual in an individualized program allows pupils to choose own method of study.	

6.03 The teacher can intervene promptly and firmly to end deviant behavior.

Prerequisites: Competencies 1.0, 2.0, 3.0, 4.0 and 5.0.
Academic and Professional Knowledge Bases.

	ACTIVITIES	CRITERIA
6.031	Practice on decision simulator.	Chooses right decision on simulator repertoire. Repeats film on simulator until correct response is attained.
6.032	Performs correctly in student teaching.	Assessment of supervising teacher or team.

6.0 Directing Off-Task Pupil Behavior (Cont.)

6.04 The teacher can reinforce acceptable behavior of pupils.

Prerequisites: Competencies 1.0, 2.0, 3.0, 4.0 and 5.0.
Academic and Professional Knowledge Bases

	ACTIVITIES	CRITERIA
6.041	Set up a contingency management system on paper.	Assessment of model by psychology professor
6.0411	A contingency is the specification of the relationship between behavior and a subsequent event. Setting up a system follows these steps:	
6.0412	Specifying the behaviors in a classroom you will want to count, being explicit and consistent. Materials to establish a base line for specifying the relationship would be a stop watch and graph paper; these would be used in an elementary classroom.	
6.0413	Counting the specified behaviors (either good or bad) for a period of time. (Examples: working independently, putting away materials, remaining in seat, hitting, raising hand.)	
6.0414	Observing the specified behaviors and recording a base line.	

6.0 Directing Off-Task Pupil Behavior (Cont.)

6.04 The teacher can reinforce acceptable behavior of pupils. (Cont.)

ACTIVITIES	CRITERIA
6.0415	Beginning the manipulation by introducing a contingency noting consequence, and deciding on reinforcement.
6.0416	Introducing the system and evaluating its' effectiveness.
6.042	Collect base line data for another teachers system.
6.043	Establish system in own room during internship.

6.05 The teacher can determine sources of deviant behavior.

Prerequisites: Academic Coursework

ACTIVITIES	CRITERIA	
6.050	Analyzes the home as a component in an environmental system; understands the roles and relationships among family members.	See Knowledge Systems
6.051	Can do a case study of a child, including anecdotal records keeping, medical records, school achievement records, interview and projection techniques	

6.0 Directing Off-Task Pupil Behavior (Cont.)

6.05 The teacher can determine sources of deviant behavior. (Cont.)

	ACTIVITIES	CRITERIA
6.052	Can isolate and describe the roles of mother, father, son, daughter, (uncle-aunt), in contemporary society.	See Knowledge System
6.053	Can compare these roles in modern society with duplicated roles in corresponding ethnic families.	See Knowledge Systems
6.054	Can draw conclusions about certain 'systems' producing value, concept, understanding, and skill development in children and deviant behavior.	See Knowledge Systems
6.055	Can use socio-metric techniques and record inter-relationships between siblings, child-parent, and child-significant person.	See Knowledge Systems
6.056	Can relate other sociological phenomena such as immorality, family income, poverty level, color, caste and segregation, malnutrition, sibling dropout, crime and delinquency, etc., to the child in a particular chosen family environmental system and draw conclusions as to these as factors in causing misbehavior.	See Knowledge Systems
6.057	Can capture and describe a particular family's atmosphere and interpret its effect on a child's behavior in that family.	See Knowledge Systems

6.0 Directing Off-Task Pupil Behavior (Cont.)

6.06 The teacher can initiate case studies when off-task behavior continually obstructs task completion.

Prerequisites: Knowledge of developing a case study: Competencies 1.0, 2.0, 3.0, 4.0 and 5.0.

	ACTIVITIES	CRITERIA
6.061	Describe different approaches to behavior control.	Academic and Professional Knowledge Bases.
6.062	Reinforce acceptable behavior of pupil.	Judgment of Team

6.07 The teacher can determine sources of inter-
personal conflict.

Prerequisites: Academic and Professional Course Work

	ACTIVITIES	CRITERIA
6.071	Analyzes self-reactions of 9.0 (conflict between child and teacher.)	Personal understanding
6.072	Applies socio-metric instruments as interaction analysis techniques.	Professional Knowledge Base
6.073	Attends course in Mental Health for the School Child. (Course is preceded by a course or program instituted in General Psychology, and Educational Psychology.)	Established by course instructor.

6.0 Directing Off-Task Pupil Behavior (Cont.)

6.08 The teacher can determine sources of inter-personal conflict.

Prerequisites: Academic and Professional Course Work

	<u>ACTIVITIES</u>	<u>CRITERIA</u>
6.081	Assist in the resolution of inter-personal conflict.	Established by course instructor
6.082	Practice resolutions in student teaching.	Supervising teachers assessment
6.083	Attending counseling sessions and/or work in clinics.	Team Assessment

6.09 The teacher can distinguish between habitual and temporary deviant behavior.

Prerequisites: Academic and Professional Courses:
Observational skills and records of child behavior

	<u>ACTIVITIES</u>	<u>CRITERIA</u>
6.091	Determine sources of inter-personal conflict: attends course on Mental Health.	Established by course instructor.
6.092	Assist in the resolution of inter-personal conflicts.	Team Assessment

6.0 Directing Off-Task Pupil Behavior (Cont.)

6.10 The teacher can distinguish between habitual and temporary deviant behavior and inter-personal conflict.

Prerequisites: Academic Course Work and Professional Knowledge Base

	ACTIVITIES	CRITERIA
6.101	Initiates case studies when off-task behavior continually obstructs task completion.	Team Assessment
6.102	Apply case study findings in a clinical environments and instructional setting as base-line data or specified state of the learner.	Team Assessment

6.11 The teacher can involve pupils periodically in evaluation of behavior control procedures.

Prerequisites: 6.01, 6.02, 6.03, 6.04 and 6.05, etc.

	ACTIVITIES	CRITERIA
6.111	Student teaching experience.	Supervising teacher assessment.

6.12 The teacher can use consultation from colleagues and para-professionals in dealing with behavior control and direction.

Prerequisites: All previous

	ACTIVITIES	CRITERIA
6.121	Assistant Teaching Experience	Assessment

APPENDIX C.

MATHEMATICS MODULE

**MATHEMATICS TEACHER EDUCATION MODULE
SHOWING
INDIVIDUALIZED INSTRUCTION**

The knowledge base in mathematics for elementary teachers is provided in a series of 20 units. Each unit uses an instructional mode which is representative of the individualized instruction model. Included in the model are academic and professional classes, individual study, and clinical experiences.

A teacher trainee would progress through the math module in the following manner:

1. **Assessment:** Placement tests on number systems, algebra, geometry is administered to determine the general state of the learner regarding achievement.
2. **Diagnosis:** Learner characteristics are recognized.
3. **Long-Term Planning:** A long-term plan is developed with the student.
4. **Assessment:** Pretests are administered for each specific unit.
5. **Short-Term Planning:** A short-term plan is developed with the student. Alternative learning routes are developed.
6. **Assessment:** Posttests are administered for each specific unit.
7. **Alternative Learning Routes:** The student selects a learning route from alternatives. Different modes of learning are available including problem-solving labs and special help activities.
8. **Evaluating:** Depth studies are initiated on subjects who have experienced difficulty in the process of following a learning plan.

The following outline of content would be included in the
Mathematics Module:*

- A. Liberal Arts Component - A series of units regarding the general structure and process of mathematics as a field of knowledge.
 1. Introduction to Mathematics
 - a. History of Mathematics
 - b. Structure of Mathematics Knowledge
 - c. Logic

- B. Education Component - A series of units regarding math content for elementary teachers
 1. Structure of the Number System
 - a. Sets
 - b. The Set of Counting Numbers
 - c. Numeration System
 - d. Subtraction and the Set of Integers
 - e. Elementary Number Theory
 - f. The Rational Numbers
 - g. Decimals and the Real Number System
 - h. Finite Number Systems
 2. Algebra
 - a. The Field of Real Numbers (Review)
 - b. Linear Equations and Linear Inequalities in One Variable
 - c. Functions and Graphs
 - d. Systems of Linear Equations and Inequalities
 - e. Quadratic Equations and Factoring
 - f. The Complex Number System
 - g. Finite Number Systems
 - h. Algebraic Structures
 3. Geometry
 - a. Basic Ideas of Geometry
 - b. Plane Regions in Geometry
 - d. Space Figures
 - e. Measurement

*Parts of A and B of the module might best be prepared by faculty members from Liberal Arts and Education combined, and the division of responsibility for monitoring the operational phases of the model decided by the faculty members involved.

C. Physical Resources

1. Space Suitable for Independent Study
2. Equipment
 - a. Mathematics models
 - b. Audio-Visual
3. Printed Materials

D. Staffing

1. Lab Director - Math Educator
2. Consultant - Mathematician
3. Tutors - Math Specialists
4. Para-professional - Aides, Clerks, Managers

The following diagram illustrates the sequences of elements comprising the mathematics training module. Each element of the module is related to a competency detailed in Chapter II. The conventional pretest-prescription-posttest pattern is enlarged to include assessing, diagnosing, planning, and helping, as processes of individualization.

UNIVERSITY OF PITTSBURGH MODEL
MATHEMATICS EDUCATION FOR ELEMENTARY TEACHERS
LEARNING MODULE *

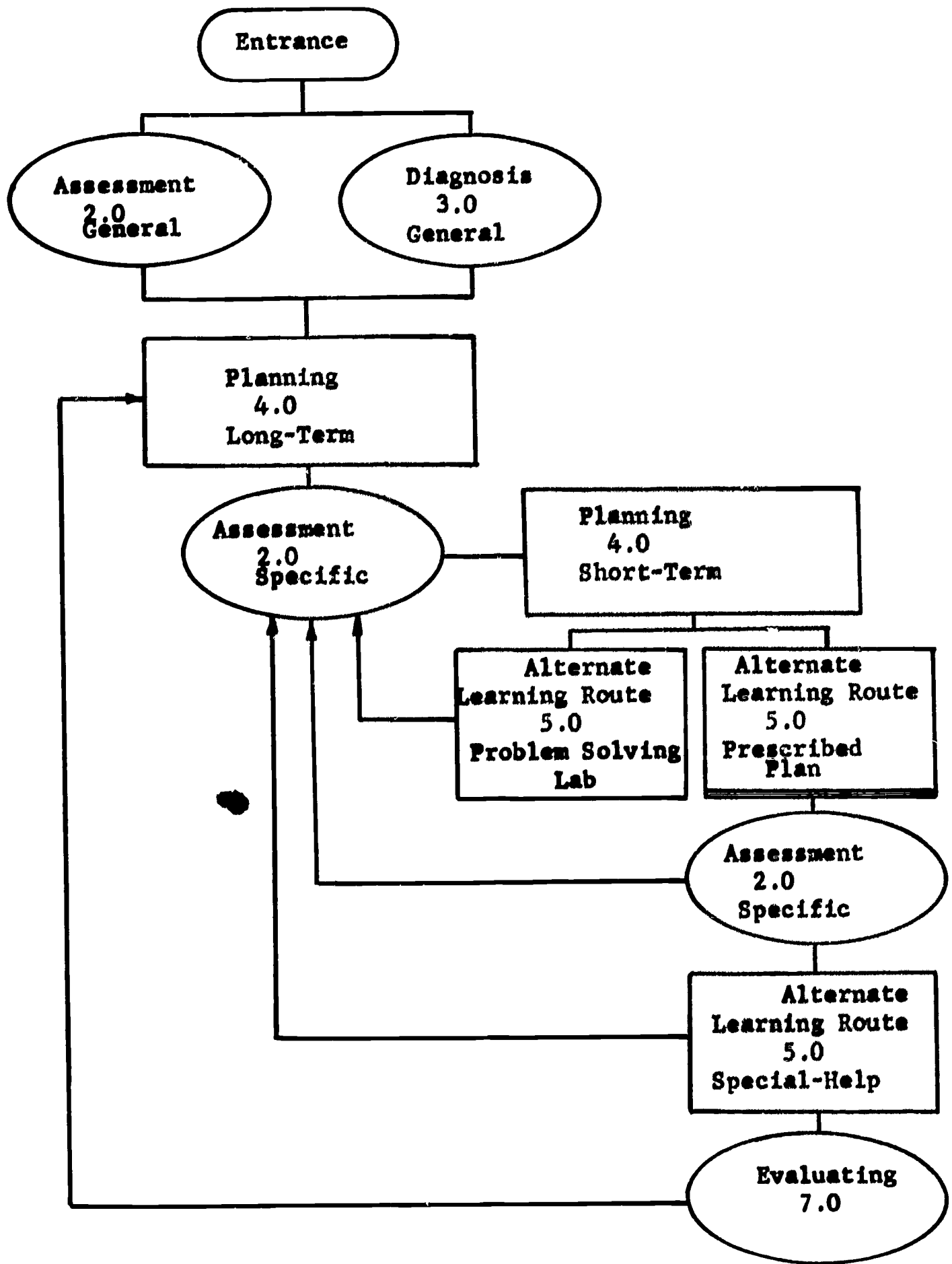

Figure No. 26 General Teaching Mode for Mathematics Education.

1. Unit I - Sets

A. Objectives . . .

This unit is designed to measure your competence to:

1. Identify definitions and notations used in developing the concept of set in elementary school mathematics programs.
2. Interpret sets and relationships among sets by Venn diagrams.
3. Prove relationships within mathematical sentences by using the properties governing the union and intersection of sets.

B. Schematic Representation of Mathematics Content

See illustration on following page.

A. Content

1. Numbers
2. Algebra
3. Geometry

C. Rationale

The idea of set is widely used in mathematics. Several reasons justify the systematic study of sets. For example, the theory of set is useful in studying the system of real numbers. In addition, the language of sets is evident throughout contemporary elementary mathematics programming.

This unit is a prerequisite for subsequent study since both the language and function of sets is employed repeatedly in the study of the number system, algebra, and geometry.

D. Materials

1. Texts

SCHEMATIC REPRESENTATION OF MATHEMATICS FOR ELEMENTARY TEACHERS

TEACHERS

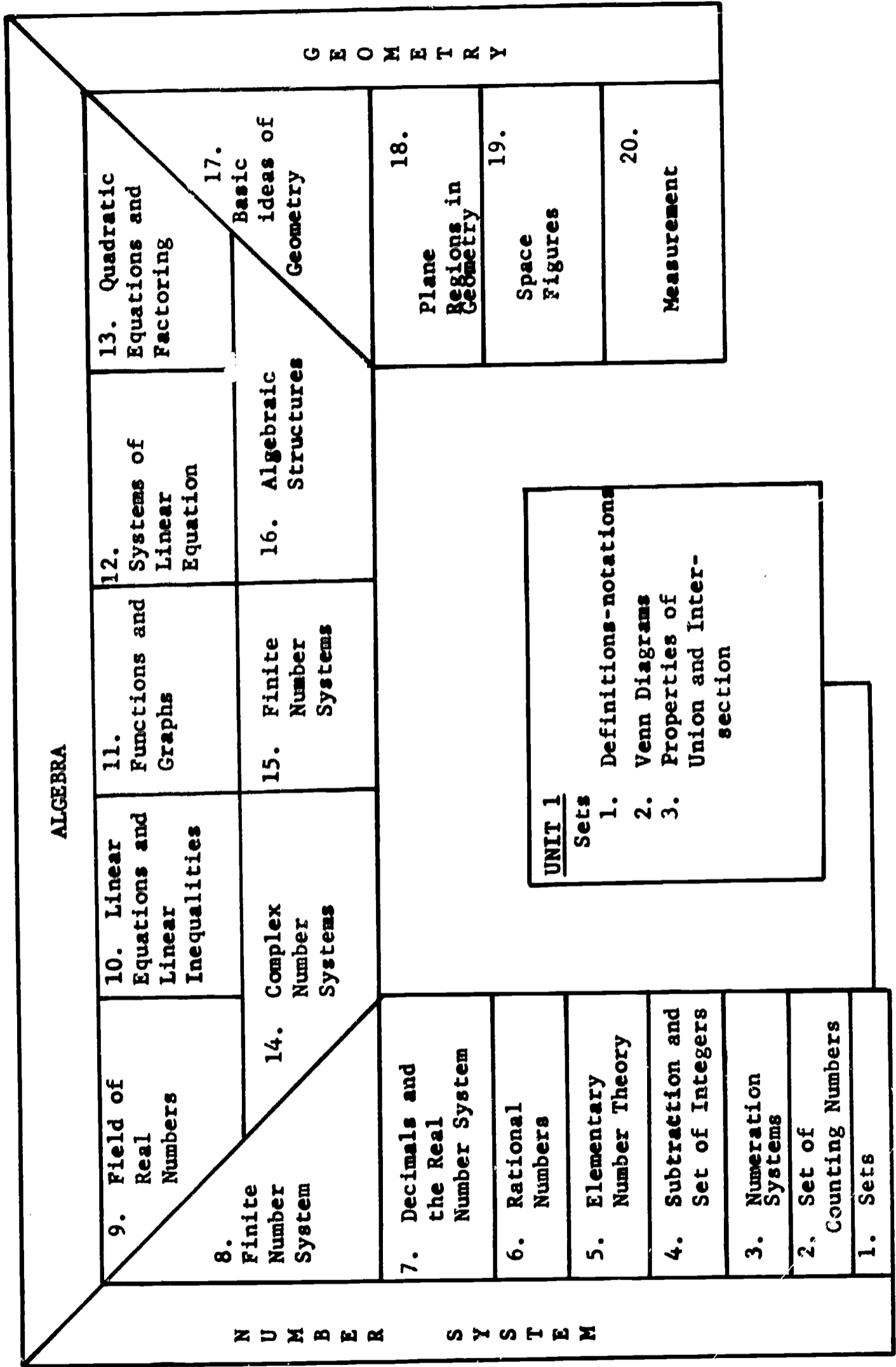

Figure No. 27. Schematic Representation of Mathematics for Elementary Teachers

- a. Building Mathematical Competence in the Elementary School - Spencer and Brydegaard.
- b. Discovering Meanings in Elementary School Mathematics - Gossnickle, Brueckner, Reckzeh.
- c. Elementary Contemporary Mathematics - Ohmer, Aucoin, Cortez.
- d. Studies in Mathematics - Vol. IX - "Brief Course in Mathematics for Elementary School Teachers" -SMSG
- e. Today's Mathematics - Heddens.
- f. Topics in Mathematics for Elementary School, Booklet No. 1, Sets, NCTM.

2. Programmed Materials

- a. Basic Mathematics - Goff and Berg (Chapter 1)
- b. Language of Sets, A Basic Systems Program - Mechner and Cook (Appleton-Century-Crofts-Lyons & Carnahan)
- c. A Programmed Introduction to Number Systems - Drooyan and Hadel (Part 1)

3. Films

Intersection of Sets - 15 min - McG-H (1-2045)
Sentences and Solution Sets - 21 min - McG-H (S-2123)
Sets, Numbers and Numerals - 30 min - SRA (M-3010)

4. Filmstrips

The Language of Sets, SUE, No. 55701
The Language of Sets, Colonial Films, No. 1-1
Modern Mathematics Scenes, Set No. 1, McG-H-071315

5. Labs (See Appendix 1)

A Block Lab (Educational Devel. Center)
Creature Card Lab (Educational Devel. Center)
People Pieces Lab (Educational Devel. Center)

E. Sequence of Events

1. Assessment - General (Placement Test)

Learners are surveyed regarding their achievement in mathematics. All areas of the curriculum in mathematics are represented in the test.

2. Diagnosis - General

The characteristics of the learner are identified in order to accommodate his most efficient way of learning.

3. Assessment - Specific (Pretest)

The pretest will serve to analyze the learners competence regarding set definitions, notations, Venn diagrams, and the properties governing the union and intersection of sets.

4. Alternate Learning Routes

- a. Most learners should first review at least one chapter on Sets in any one of the texts.
- b. Programmed material should be used after an exposure to Sets through the texts.
- c. Filmed material may be used as the student prefers. At least one film should be viewed on Sets.
- d. Filmstrips also are to be used at the discretion of the learners. If the student feels further reinforcement is unnecessary, he may select to avoid these materials.
- e. Learners choosing to use the Problem Solving Labs may select to begin with any lab in this unit. Directions for the lab are clearly prepared.

5. Assessment - Specific (Posttest)

a. Prescribed Plan

This posttest will evaluate the learners understanding of Set definitions, notations, Venn diagrams, and properties governing Set union and intersection.

b. Problem Solving Lab

Lab experiences will be assessed in terms of both the product and process.

6. Evaluating

- a. Review the learning style of the student
- b. Evaluate the pretest-prescription-posttest phases in order to locate the area of difficulty
- c. Prescribe the short-term experience
- d. Evaluate the short-term experience

CREATURE CARD LAB

LEARNING OBJECTIVE:

1. To write descriptions of sets of figures having some consistent feature.
2. To classify figures according to the written descriptions of sets.

DESCRIPTION:

This lab includes 15 creature cards. The student must identify the features or attributes of two groups of figures. The final step of each card involves the classification of a series of figures in the third row of each card.

EXAMPLE:

Creature Card 1

1. Set A includes the figures which are labeled 'Gligs.'
2. Set B includes the figures which are not labeled as 'Gligs.' Write a description of Set B.
3. Classify each figure in the third row as belonging to either Set A or Set B.

Creature Card 1 'Gligs'

All of these are Gligs.



None of these are Gligs.



Which of these are Gligs?



DIRECTIONS:

Follow the questions included on the enclosed worksheet. The difficulty of the task gradually increases such that Card 15 is usually considered the most difficult. Learners are free to select cards for this activity.

'A' BLOCK LAB

OBJECTIVE: To make concrete representations of a variety of written descriptions using the language of set theory.

DESCRIPTION: This Lab includes 5 groups of 'A' Block Cards. A wide range of directions are included on these cards. Usually, the student works alone. However, certain cards require the learner to have a partner.

Answer sheets are not provided because of the diverse nature of each card. Learners should record appropriate responses on a separate paper. Identify each answer sheet with your name, date of completion, and card number.

DIRECTIONS: The 5 groups of cards are assembled as follows:

Group I - Cards 4, 5, 6, 7, 8, 9, 10

Group II - Cards 14, 15, 16, 17, 18, 19, 20, 21

Group III - Cards 23, 24, 25, 26, 27, 28, 29

Group IV - Cards 31, 32, 33, 34, 35

Group V - Cards 36, 37, 38, 39

Each group of cards should be completed before proceeding to the next group. Groups should be followed in a consecutive pattern. Learners are free to select the number of cards for study in this Lab.

PEOPLE PIECES LAB

OBJECTIVE: To make concrete representations of a variety of situations to compare representations of written directions by working in partnership with another learner.

DESCRIPTION: The 'People Pieces Lab' includes 16 cards of directions. The difficulty of tasks increases with each card.

Learners will be required to apply their understanding of attributes and values by use of a matrix.

DIRECTIONS: Learners are to work in pairs in this Lab. The responsibility for the organization of student pairs is the learners.

Cards are to be followed consecutively. Results are not recorded in written form, but the learning pairs must interact to assess the product. The learners are free to use as many cards as desired in this Lab.

Record should be kept of the number of cards completed, and the sequential location of this Lab in the total learning experience regarding sets.

APPENDIX D
SCIENCE MODULE

KNOWLEDGE SYSTEM: SCIENCE

Just as the entire program of teacher education must prepare the trainee for the new and changing school situations in which he will operate, the knowledge of science that the program prescribes must be consistent with the type of elementary-school science instruction in which he will engage. It will be profitable, therefore, to characterize briefly the main features of the emerging elementary-school science curriculum, whose goals and instructional procedures are generally quite different from those of science programs of the past.

While formerly science was often taught in elementary schools for fun or diversion, the new science curriculum emphasizes the teaching of science for intellectual enjoyment. While good science programs of the past tried to encourage children to find answers to problems set by the teacher or text, the new science curriculum places major emphasis on developing the student's process skills that make it possible for him to obtain scientific data and to organize and interpret them in meaningful ways. While past science programs were strong on the learning of facts and information, the new science curriculum focuses on the major concepts, principles, and conceptual schemes of science. While elementary-school science teaching formerly dealt solely or mostly with the scientific aspects of the topics taken up, the new science curriculum gives particular attention to the interactions of science and society.

To sum up, the teacher in the modern elementary school will be expected to teach science as a process for intellectual discovery and with emphasis on:

- 1) the processes of scientific inquiry
- 2) major concepts, principles, and conceptual schemes of science
- 3) the social aspects of science

It is clear that the teacher's role in the new science curriculum is primarily to guide inquiry, rather than to dispense knowledge. To be able to fulfill this role, the teacher must understand the nature of scientific inquiry and must himself have had some experience in conducting inquiries. To provide this and other relevant learning experiences for the prospective teacher, the following units of the Science Knowledge System have been designated:

- Unit S1 The Nature of Scientific Inquiry**
- S2 Inquiry in Science**
- S3 Major Ideas of Science**
- S4 Social Aspects of Science**
- S5 Science and Children**
- S6 Science Instruction**

Units S1 through S4 are part of the Liberal Arts segment of the teacher education program. Two or more alternative instructional modes will be available for each of these units. Written appraisal tests will be constructed for units S1, S3, and S4 to measure mastery of the ideas included in the unit. Mastery will be assessed by performance tests in unit S2, which consists of carrying out a scientific investigation. Units S5 and S6 are part of the Education component of the program. Two alternative instructional modes will be available for unit S5, but only one instructional mode, a practicum experience, will be offered for unit S6. The chart on the next page shows the instructional mode of the Science Knowledge System and indicates alternative routes (dashed lines) that an individual may follow. Further specifications for all the units are given on the following pages.

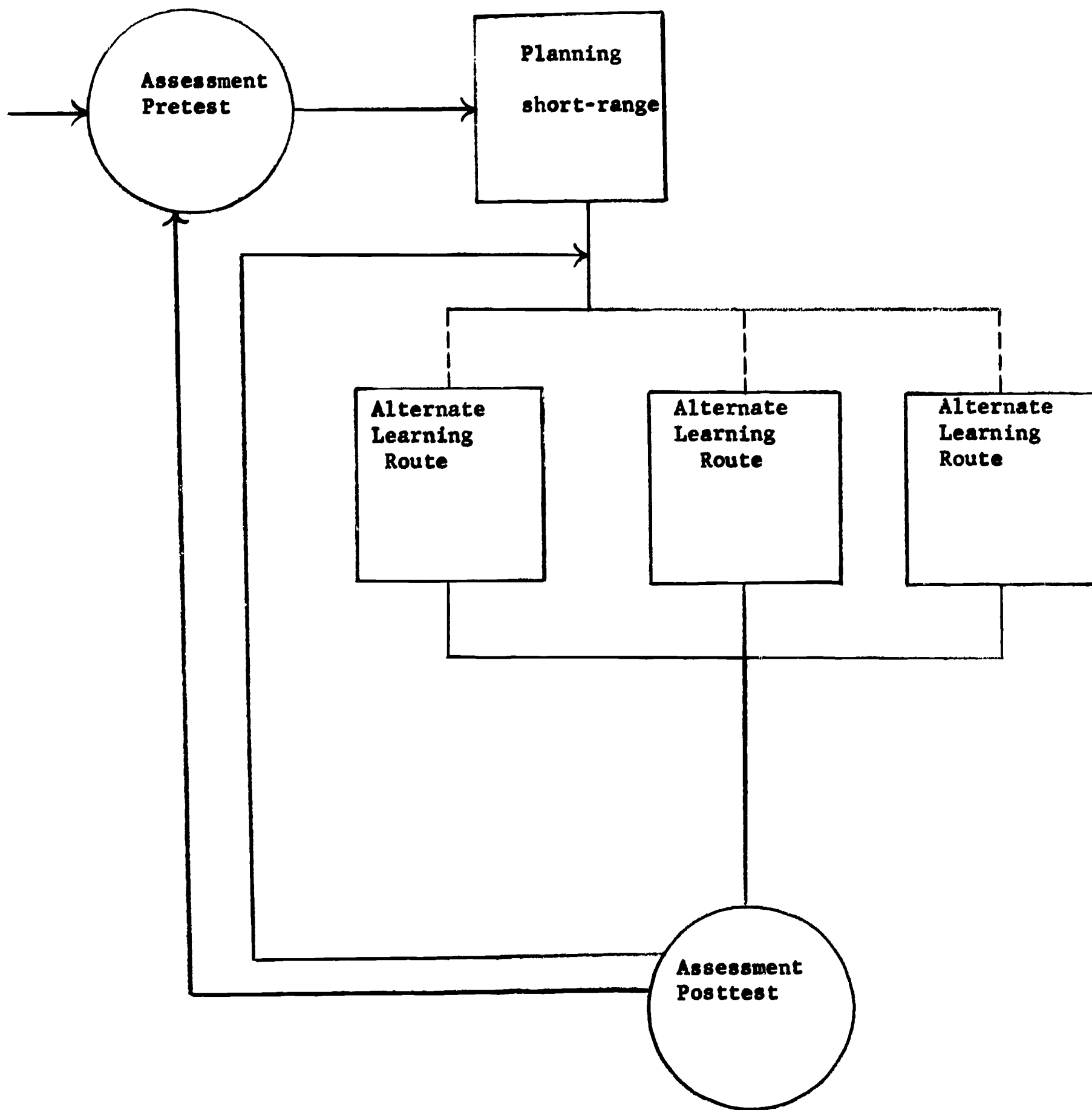

Figure No. 28. Science Education for Elementary Teachers: Learning Module.

UNIT S1 THE NATURE OF SCIENTIFIC INQUIRY

This unit is intended to develop the prospective teacher's understanding of scientific inquiry, so that he will have the necessary intellectual base for conducting his own inquiries and for helping elementary-school students to inquire. An appraisal test which measures mastery of the ideas of the unit is taken by every student upon entry into the program. If he has mastery, he need not study in this unit and may proceed to unit S2, Inquiry in Science; if his test result does not show mastery, he selects one of the three alternate learning modes offered for study in unit S1. Study in unit S1 may be, but need not be, concurrent with study in units S3 and S4.

The understanding to be developed in this unit is defined by the set of interlocking ideas about the nature of scientific inquiry that are outlined below. This outline is a result of a reductionist analysis of scientific inquiry into its substrata of levels of organization. In this view, scientific inquiry is a purposeful, complex, cybernetic system with multiple feedback loops. As a system, scientific inquiry exhibits becoming, being, and behaving, and these have been used as the major categories of the outline.

Becoming, being, and behaving are interconnected. Becoming refers to the historical aspects of scientific inquiry and may be represented as progression along a timeline. Being refers to the structure of scientific inquiry at a particular point in time and may be represented by a cross-section orthogonal to the timeline. Behaving consists of the application of processes by means of which the system of scientific inquiry in being responds to stimuli, which serve to regulate the system through displacement-correcting responses. History produces structure, and structure determines function; becoming gives being, and being is capable of behaving.

IDEAS CONCERNING THE NATURE OF SCIENTIFIC INQUIRY

I. General

A. Definition -SCIENCE IS AN EXPLORATION BY MAN OF THE NATURAL UNIVERSE THAT SEEKS ORDERLY RELATIONSHIPS AMONG PHENOMENA AND THAT IS SELF-TESTING.

1. ASSUMED ARE: A UNIVERSE THAT IS ORDERLY AND THAT SENSATIONS MAY CONTAIN INFORMATION ABOUT IT.

B. Scope - THE DATA OF SCIENCE ARE OBSERVATIONS THAT CAN BE REPEATED BY ANY NORMAL PERSON WITH APPROPRIATE INSTRUMENTS AND TRAINING.

1. Unique events occur, but evidence on them is acceptable if there is confidence that anyone in a position to observe them would have observed them.
2. Those aspects of experience of interest to science are those which satisfy the available procedures for rationalizing data.

C. Unity - Diversity

1. THERE IS UNITY IN SCIENCE DUE TO PURPOSE, SIMILARITY OF METHODS, AND FACT THAT ALL DISCIPLINES STUDY SYSTEMS OF WHICH AT LEAST ONE COMPONENT IS BIOLOGICAL - THE OBSERVER, MAN.
2. Relative distinctiveness of two major types of disciplines.
 - a) those having a strong temporal or historical element and for which both reductionist and compositionist methods are needed - principally evolving systems
 - b) those for which the temporal or historical element is largely ignored and for which reductionist methods seem adequate - the so-called exact sciences

II. Becoming - progression of science up to the present time

A. THEORIES, LAWS OF NATURE, AND CONCEPTS OF SCIENCE ARE DYNAMIC AND CHANGE IS SELF-ACCELERATING.

1. THE GROWTH OF IDEAS OVER TIME IS CHARACTERISTIC OF SCIENCE.
 - a) An example is the distinction and historical derivation of "intelligible principles" as contrasted with "general principles of science."
2. IN SCIENCE, ANSWERING ONE QUESTION, RAISES MANY OTHERS.
3. WHEN CONTROVERSY IN A PARTICULAR AREA OF SCIENCE HAS BEEN SATISFACTORILY RESOLVED AND A THEORETICAL EXPLANATION GENERALLY ACCEPTED, AN ERA OF RAPID ADVANCE IN THAT AREA FREQUENTLY FOLLOWS.

4. MODERN SCIENCE IS GROWING EXPONENTIALLY.

- a) THE "REDOUBLING RATE" IS CURRENTLY LESS THAN A DECADE.**
- b) MUCH SPECIFIC KNOWLEDGE BECOMES TRIVIAL AFTER A SHORT TIME EITHER BECAUSE IT CAN BE SUBSUMED BY A THEORY OR IT FAILS TO LEAD TO FURTHER DISCOVERY.**

B. SCIENTIFIC KNOWLEDGE IS TENTATIVE.

- 1. WITHIN THE EVOLUTION OF SCIENTIFIC KNOWLEDGE, THE ORDER OF RELATIVE LONGEVITY IS: META-PHYSICAL PRINCIPLES, THEORIES, LAWS OF NATURE AND CONSTRUCTS.**
- 2. THE LAWS OF SCIENCE DEAL WITH INCOMPLETE CYCLES WITHIN WHAT MAY BE A TOTALITY OF NO CYCLES (AS IN HISTORY).**

C. THE TREND IN ALL SCIENCES IS FOR THEM TO BECOME INCREASINGLY THEORETICAL AND EXACT, THE BIOLOGICAL SCIENCES BEING CURRENTLY MORE CORRELATIONAL AND THE PHYSICAL SCIENCES MORE EXACT. Models have become increasingly abstract and theoretical -- physical models give way to mathematical models.

- 1. A natural law is a statement which has evolved from a definition to a mathematical equation.**
- 2. THE DEVELOPMENT OF INQUIRY IN BIOLOGY IS MOVEMENT FROM SIMPLE OBSERVATION, TO TAXONOMY, TO DESCRIPTIVE MORPHOLOGY, TO THE ADDITION OF ANALYSIS TO DESCRIPTION.**
- 3. SOME BIOLOGISTS ARE ATTEMPTING TO MOVE TOWARD DEDUCTIVE PATTERNS OF THOUGHT AND TO THE DEVELOPMENT OF DEDUCTIVE THEORIES, I.E. EXPLANATORY SYSTEMS THAT WILL BE PREDICTIVE.**
- 4. SCIENTIFIC THEORIES CONSIDERED TO EXPLAIN "WHY" BECOME, IN THE COURSE OF TIME, TO BE CONSIDERED AS DESCRIPTIONS OF "HOW." NEWER, MORE COMPREHENSIVE THEORIES THEN GIVE "WHY."**
- 5. TELEOLOGY HAS HAD AN EVOLVING ROLE IN THE BIOLOGICAL SCIENCES AND IN THE SHIFT FROM MECHANISTIC TO STATISTICAL CONCEPTIONS IN BOTH BIOLOGICAL AND PHYSICAL SCIENCES.**

III. Being - the current theoretical framework of the exact sciences and, where such frameworks are developed, in the largely correlational sciences.

A. PHYSICAL REALITY EMERGES FROM THE INTERACTION OF TWO ASPECTS OF EXPERIENCE:

- 1. SENSE DATA or the immediate - too spontaneous and ephemeral**
- 2. CONSTRUCTS or the rational - too subjective when untested**
- 3. Interaction of sense data and constructs - VALIDITY AND RELEVANCE ARE THE CRITERIA BY WHICH CONSTRUCTS ARE SELECTED.**

a) VALIDATION IS A THREE-FOLD PROCESS and results in verifacts

(1) CONSTRUCTS MUST UNDERGO IMPOSITION OF THE METAPHYSICAL REQUIREMENTS

- (a) logical fertility, multiple connections, causality, simplicity and elegancy, permanence and stability, extensibility**
- (b) CERTAIN ASSUMPTIONS SERVE AS CONSTRAINTS AND GUIDES IN THE EVOLUTION OF SCIENTIFIC KNOWLEDGE AND THUS BECOME A PART OF THE STRUCTURE OF SCIENCE.**

(2) CONSTRUCTS MUST SUCCESSFULLY COMPLETE A CIRCUIT OF VERIFICATION.

- (a) circuit begins with sense data**
- (b) proceeds by means of rules of correspondence to the constructional realm**
- (c) constructs undergo logical transformation by means of constitutive definitions or operations**
- (d) return by rules of correspondence to sense data**

- (3) **CONSTRUCTS MUST ESTABLISH RULES OF CORRESPONDENCE (epistemic definitions or correlations) WHICH LINK DATA TO CONSTRUCTS; among more common examples, in order of depth of penetration into constructional realm, are:**
- (a) rules of reification
 - (b) assignment of qualities not read from data (e.g., mass)
 - (c) operational definitions (color as a wave length)
 - (d) sensory representation (graphing) of phenomena not directly sensible (construction from mathematical/instructional processes of a property such as field strength)
 - (e) the assertion of entities from a given complex of data -- electrons, photons
- b) **RELEVANCE IS THE EXTENT TO WHICH VERIFACTS ARE EMBEDDED IN AN ALREADY ESTABLISHED THEORY, a web-like structure of constructs interrelated through constitutive definitions**
- (1) **CONSTITUTIVE DEFINITIONS MAY BE LOGICAL OR MATHEMATICAL OPERATIONS OR RELATIONS.**
 - (2) **DEDUCTIVE FERTILITY EMERGES FROM THE INTERPLAY OR TWO MODES OF DEFINITION, CONSTITUTIVE AND EPISTEMIC.**
- c) **THE CONTEMPORARY STATUS OF CONSTRUCTS DEPENDS ON WHAT OPERATIONS DEFINE THE CONSTRUCTS, WHAT CONSTRUCTS ARE EQUALLY SUPPORTED BY THESE OPERATIONS, AND WHAT OTHER FACTORS GIVE PREFERENCE TO THE PREFERRED CONSTRUCTS.**
- d) **PHYSICAL CONSTRUCTS ARE MULTIDIMENSIONAL; i.e., instrumental, paper-and-pencil, and verbal operations may each contribute to the definition of constructs.**

4. VERIFACTS (valid constructs) ARE THE ELEMENTS OF PHYSICAL REALITY, ALTHOUGH THEY ARE NOT ALL OF PHYSICAL REALITY.

a) "CONSTRUCTS ARE NOT VALID BECAUSE THEY REFER TO SOMETHING REAL; THEY DENOTE SOMETHING REAL BECAUSE THEY HAVE BEEN FOUND TO BE VALID...REALITY IS CONFERRED JOINTLY BY THE PROCESS OF FITTING NEW PARTS INTO AN ALREADY EXISTING STRUCTURE AND BY THE PROCESS OF EMPIRICAL VALIDATION." (MARGENAU)

b) THREE KINDS OF VERIFACTS MAY BE RECOGNIZED:

(1) SYSTEMS - constructs which serve in a substantial role as a carrier of observable properties

(2) STATES - consist of quantified observable properties used to define and describe systems

(a) selection of properties to be used to define a state is crucial

(b) criteria for sufficiency must be invoked

(3) OBSERVABLE PROPERTIES - two types

(a) possessed - those which apparently are unaffected by observation

(b) latent - those which apparently are affected by observation (those for which the rules of correspondence must be statistical)

B. The nature of natural law and theory and their roles in determining the nature of physical reality

1. NATURAL LAW - A GENERALIZING CONSTRUCT WHICH INTER-RELATES STATES OF A SYSTEM or a class of systems AND IS FORMULATED IN A SINGLE STATEMENT.

a) A LAW MAY BE AN INDUCTIVE GENERALIZATION BASED ON RELATIONS FOUND TO HOLD IN OBSERVED DATA, or on other laws which are directly or indirectly based on such relations.

b) A LAW MAY BE DEDUCED FROM THEORY in which case it potentially provides another link between theory and observable data.

c) **LAWS ARE STATABLE AND VERIFIABLE INDEPENDENTLY OF THE THEORIES WHICH MAY EXPLAIN THEM OR HAVE GIVEN RISE TO THEM.**

(1) Each term used in stating a law has meaning independently of the law; i.e., is an observable, directly or indirectly.

d) **LAWS HAVE LIMITED PREDICTIVE AND EXPLANATORY POWER.**

(1) Some biologists admit polytypic concepts into law-like statements that preclude prediction in the sense usually required by laws in the physical sciences.

(a) Functional analyses, so widely used in biology, do not produce explanatory schemes which become parts of theories in an exact science, and such a methodology may not be capable of yielding such explanatory schemes.

2. **THEORY - DYNAMIC INTERRELATED WEB OF CONSTRUCTS, CONSTITUTING A POSTULATIONAL SYSTEM, WHICH PROVIDES THE RATIONAL CONTEXT IN TERMS OF WHICH LAWS CAN BE INTERPRETED, DEDUCED AND EXPLAINED.**

a) **THEORY HAS GENERALITY AND PREDICTIVE AND EXPLANATORY POWERS TRANSCENDING LAW.**

(1) At least one of the entities used in the postulates is defined only implicitly by the context of the postulates and is not derivable from observed data.

(2) More degrees of freedom are available (than for laws) because of complex symbolic structure of theories and relative freedom in selecting entities.

(3) There are differences between deductive theory and inductive generalizations.

(a) **A SYSTEM OF CLASSIFICATION IS NOT A DEDUCTIVE SYSTEM, ALTHOUGH IT MAY PROVIDE SUGGESTIONS AS TO RELEVANT RELATIONSHIPS.**

- b) THEORIES HAVE CORRELATIVE, HEURISTIC AND EXPLANATORY FUNCTIONS.
 - (1) THEORIES ARE PROPOSED AS PRELIMINARY PHENOMENOLOGICAL DEVICES IN THE HOPE THAT THEY WILL FACILITATE THE DISCOVERY OF MORE ADEQUATE EXPLANATIONS.

- c) IN ORDER FOR THEORIES TO FULFILL THESE FUNCTIONS THEY MUST HAVE THREE MAJOR COMPONENTS:
 - (1) AN ABSTRACT RELATIONAL STRUCTURE that is the logical skeleton of the explanatory system, and that implicitly defines the basic notions of the structure (analogous to system in laws)
 - (a) THE ORGANIZATION OF BIOLOGICAL CONCEPTS BY MEANS OF A TWO-DIMENSIONAL GRID, WITH LEVELS OF ORGANIZATION ON ONE AXIS AND "BEING: ORGANIZATION;" "BEHAVING: REGULATION;" AND "BECOMING: HISTORY" ON THE OTHER AXIS IS A USEFUL PATTERN OF VISUALIZATION.
 - (b) Some biologists utilize model-explanations and theories made up of families of models and currently see these as the only theories in some areas of biological inquiry.
 - (c) THE TERM "MODEL" MAY BE USED IN THE BIOLOGICAL SCIENCES IN THE PHRASE A "FAMILY OF MODELS" AS DEFINING A THEORY WHICH SERVES TO INTERRELATE CONCEPTS AT DIFFERENT LEVELS OF ORGANIZATION.
 - d) THEORIES ARE VALIDATED IN MUCH THE SAME WAY AS MORE RESTRICTED CONSTRUCTS, through a circuit of verification, but in addition, SUCCESSES OF A THEORY ARE MEASURES NOT ONLY OF ITS USEFULNESS BUT ALSO OF ITS CREDIBILITY.

- 3. There are distinctions in structure and development between the inductive and deductive aspects of theory.
 - a) THE PROCEDURES OF CONTEMPORARY SCIENCE USE INDUCTIVE AND DEDUCTIVE PROCESSES IN AN OVERLAPPING INTEGRAL RELATIONSHIP.

- b) ALL CONCEPTUAL SCHEMES ARE BUILT UP FROM INDUCTIONS WHICH IN TURN HAVE BEEN IN PART ACHIEVED THROUGH PRIOR DEDUCTIONS FROM EXISTING THEORIES.
- c) In their inductive organization, theories are structured by the consequence relation, and in their deductive analysis, by the definability relation.
- d) A DIVERSITY OF THEORETICAL APPROACHES IS USED BY PRACTICING BIOLOGISTS ATTEMPTING TO EXPLAIN LIVING ORGANISMS.
 - (1) There are inherent limitations in current patterns of explanation (statistical analysis and probability).
 - (2) SOME BIOLOGISTS ACCEPT NON-CAUSAL EXPLANATIONS.

IV. Behaving - strain relieving responses to internal and external stresses, effected by processes which are integrally interwoven with structure (Being)

A. Stresses or stimuli - two sources

- 1. internal - metaphysical principles of consistency, completeness and simplicity
- 2. external - supply of sense data

B. The Scientist and His Methodology - "DOING YOUR DAMNDEST WITH YOUR MIND, NO HOLDS BARRED" (Bridgman)

- 1. A theoretical scientist's work does not involve manipulation of physical materials other than those which are immediate aids to his thinking - pencil, paper, chalk, computers, etc.; but the amount of effort even an experimental scientist devotes to manipulation of physical materials, compared with that given to thinking, is as the exposed part of an iceberg is to the submerged. Yet, IT IS THIS FUSION OF THE RATIONAL WITH THE EMPIRICAL WHICH GIVES SCIENCE ITS UNIQUE POWER.

2. Certain general abilities are frequently needed by most scientists. Those marked with an (E) are of greater importance to a scientist primarily engaged in experimental work, those marked with a (T) to a theoretician. An asterisk (*) indicates that the importance of the ability varies depending upon the area of science in which the scientist works.
- a) ABILITY TO COMMUNICATE EFFECTIVELY
 - b) ABILITY TO THINK CRITICALLY
 - c) ABILITY TO ACCURATELY RECORD AND DESCRIBE OBSERVATIONS (E)
 - d) MANIPULATIVE SKILLS (E) (*)
 - e) A FACILITY IN MATHEMATICS (T) (*)
 - f) ABILITY TO DESIGN APPARATUS AND CONTROLLED EXPERIMENTS (E) (*)
 - g) ABILITY TO SEE PROBLEMS FROM A BROAD, OVERALL PERSPECTIVE (T)
3. Problems to be solved (strains to be relieved) are usually indentified by an alert person who observes an instance of inconsistency, incompleteness, or unnecessary complexity in the existing theoretical structure, or who observes some physical phenomenon not adequately explained by the existing theoretical structure.
- a) SCIENCE PROCEEDS IN A PIECEMEAL MANNER, EVEN THOUGH IT ALSO AIMS AT ACHIEVING A SYSTEMATIC AND COMPREHENSIVE UNDERSTANDING OF VARIOUS SECTORS OR ASPECTS OF NATURE.
4. The attack on a particular problem in science involves the CYCLIC INTERACTION of the instigating observation, existing theoretical structure, imagination and abstraction, analogy and certain semantic constraints, the scientist's creative ability and his constraints on creativity, metaphysical principles; hypotheses; deduction from hypotheses to prediction, with theory and rules of correspondence entering in; experimentation, which includes; the carrying out of a procedure designed to enable an observer to observe that which was predicted (the design required theoretical structure, etc.)

and permeating all of these are the relevant characteristics of the scientist/observer himself. Thus, SCIENTIFIC PROBLEM SOLVING IS A COMPLEX, DYNAMIC PROCESS.

a) THE WELL-PREPARED MIND OF AN INQUIRING SCIENTIST IS ESSENTIAL FOR DISCOVERY.

(1) Today, scientific research is sufficiently complex to necessitate long years of training for most types of work. This training usually includes several years of study after graduation from college.

b) THEORETICAL CONSTRUCTS ARE OF CRUCIAL IMPORTANCE IN THE SEARCH FOR NEW KNOWLEDGE.

c) IMAGINATION AND ABSTRACTION ARE ESSENTIAL CHARACTERISTICS OF THE PROCESSES OF DISCOVERY IN SCIENCE.

d) ANALOGY IS A METHOD OF DISCOVERY, BUT ALSO IT LACKS COMPLETE AND UNIQUE CORRESPONDENCE.

e) THE WORKING SCIENTIST INVENTS HIS SIGNS IN ORDER TO MAKE PRESENTATIONS OF PHENOMENA -- THE RELATIONSHIPS BETWEEN THESE SIGNS AND SYMBOLS AND THE OBJECTS OF INTEREST TO SCIENTISTS ARE THE SEMANTICAL COMPONENTS OF SCIENCE.

(1) MAN IS AN INTERPRETER OF NATURE AND, AS A CONSEQUENCE, THE STUDY OF LANGUAGE IS AS ESSENTIAL TO THE SCIENTIST AS THE STUDY OF OBSERVATION.

(a) THE RECORDING OF OBSERVATIONS AND THE CREATION OF HYPOTHESES ARE IMPOSSIBLE WITHOUT EACH OF THESE.

(b) NATURAL LANGUAGE HAS DECREASING UTILITY AS A SCIENCE DEVELOPS.

(c) A DELIBERATELY CONSTRUCTED AND APPROPRIATE LANGUAGE CAN SERVE SCIENCE BY SERVING AS A CHECK ON UNAIDED INTUITION AND BY EXTENDING THE SCOPE OF INTUITION.

- 1) It is only when one uses one language that reduction is possible in seeking to compare theories -- when languages are mixed, only interpretability is possible in making comparisons.
 - ii) If science wishes to remain within the domain of the physical language, there are many phenomena with which it is impossible to deal - those areas which require the use of sensible object language, person language, and community language.
 - iii) Set theory and symbolic logic provide clarification of relations, utilize the extensional point of view, and assists in constructing a more controllable language.
- f) MODELS AND VISUALIZATIONS ARE USED BY THE SCIENTIST TO ASSIST HIM IN ORGANIZING HIS RELATIONSHIPS INTO A UNIFIED WHOLE AND TO ASSIST HIM IN THE FORMULATION OF HYPOTHESES.
- (1) The term "model" may be used in science to illustrate various sets of relationships and may be linguistic, mathematical, mechanical, etc.
 - (2) THEORIES AND MODELS ARE IDEALIZATIONS THAT ARE WIDELY USED IN SCIENCE, BUT CANNOT BE CLAIMED TO REPRESENT CORRECT PICTURES OF NATURE. THEY ARE NOT EVEN, IN THEMSELVES, ATTEMPTS TO DEFINE AN "ULTIMATE REALITY."
- g) CHANGES IN METAPHYSICAL PRINCIPLES CAN BRING ABOUT PROFOUND CHANGES IN THE STRUCTURE OF SCIENTIFIC KNOWLEDGE.
- h) The essential relationships within all exact or deductive sciences are logical and mathematical.
- i) THE MOST WIDESPREAD AND CONCLUSIVE PROCESS OF SELF-TESTING IN SCIENCE IS TESTING BY MULTIPLICATION OF RELEVANT OBSERVATIONS WHICH CAN ONLY INCREASE CONFIDENCE WITHIN A NARROWING RANGE OF PROBABILITY. IF CONFIDENCE BECOMES SUFFICIENTLY GREAT AND THE RANGE IS ENCOMPASSED BY THE HYPOTHESIS, THE HYPOTHESIS IS SAID TO BE CONFIRMED.

- (1) Relevant observations are those which are potentially capable of disproving the hypothesis.
 - (a) PREDICTION IS ONLY A SPECIAL FORM OF RELEVANT OBSERVATION: THAT FOR WHICH FAILURE TO OCCUR WOULD DISPROVE THE HYPOTHESIS.
 - (b) Prediction is possible only when the terms within the principles of science have been given their operational definitions.
 - (c) Prediction is made more difficult in biology by the unique event and appropriate logical, mathematical, and syntactical procedures will be needed to cope with explanatory, or deductive, theories and processes in which such unique events may need to be provided for.
- j) Observations and ideas may lead a scientist to predict certain phenomena and behaviors in nature, and he must question nature to find out whether his predictions are correct. CARRYING OUT EXPERIMENTAL TESTS AND MAKING ACCURATE OBSERVATIONS ARE THE SCIENTIST'S MEANS FOR ASKING SUCH QUESTIONS.
 - (1) THE RELATIONSHIP OF THEORY TO OBSERVATION IS CRUCIAL -- WITHOUT THEORY MAN DOES NOT KNOW WHAT TO OBSERVE.
 - (2) RELATIONSHIPS MUST BE EXPRESSED IN TERMS OF SPECIFIED VARIABLES.
 - (a) IN CERTAIN SCIENTIFIC EXPERIMENTS, WHERE ALL THE SIGNIFICANT VARIABLES HAVE NOT BEEN CLEARLY IDENTIFIED, IT IS NECESSARY TO USE CONTROLS. IN A SIMPLE CONTROL EXPERIMENT, THE CONTROL SAMPLE IS TREATED EXACTLY THE SAME AS THE EXPERIMENTAL SAMPLE EXCEPT FOR THE EXPERIMENTAL FACTOR.
 - (3) INSTRUMENTAL OPERATIONS HAVE A CRITICAL ROLE IN DEVELOPING PHYSICAL CONTENT IN CONCEPTS.

- (a) Scientists doing research frequently require specialized instruments and equipment to carry out experiments and make observations. AS EXPERIMENTS BECOME MORE PRECISE AND SOPHISTICATED, IMPROVEMENTS MUST BE MADE IN THE SCIENTIFIC INSTRUMENTS AND EQUIPMENT EMPLOYED.
 - (b) THE AVAILABLE AND CREATED INSTRUMENTS ARE PART OF THE CONSTRUCTIONAL ACTIVITY THROUGH WHICH AN OBSERVER CARRIES FORWARD EXPERIMENTATION WHICH RESULTS IN A FURTHER DEFINITION OF REALITY.
 - 1) INTRODUCTION OF A NEW INSTRUMENT OR TECHNIQUE MAY LEAD TO A NEW EPOCH OF SCIENTIFIC PROGRESS.
 - (c) NO OBSERVATION RECORD IS UNDERSTANDABLE WITHOUT KNOWLEDGE OF THE THEORY WHICH UNDERLIES THE INSTRUMENTS USED IN OBSERVATION.
 - (d) ALL THAT REPETITION AND INSTRUMENTAL REFINEMENT CAN DO IS TO GENERATE A DEGREE OF CONFIDENCE THAT A MEASUREMENT (at any given time and under given conditions) LIES WITHIN A CERTAIN RANGE. Inference from observation takes into account the size of the range and the degree of confidence.
 - (e) With many phenomena THE WHOLE POINT OF OBSERVATION IS NOT AN EXACT MEASUREMENT OR DETERMINATION OF OCCURRENCE BUT ESTABLISHMENT (to some degree of confidence) OF A PROBABILITY.
- k) Operational analysis has become an important part of methodology.
- (1) THE NATURE OF OPERATIONS PERFORMED BY SCIENTISTS IN DEVELOPING EXPLANATIONS OF NATURAL PHENOMENA DETERMINE THE NATURE OF THE EXPLANATIONS.
 - (2) DIFFERENT OPERATIONS REINFORCE AND SUPPLEMENT EACH OTHER.
- 1) THE ORDERED OBSERVER IS A CONSTRUCTOR OF REALITY.

(1) THERE IS AN INSEPARABLE RELATIONSHIP BETWEEN THE BACKGROUND OF A PERSON AND HIS DISCOVERY AND INTERPRETATION OF NATURE.

(a) Other areas of man's thinking or beliefs, in religion, logic, mathematics, technology, etc., may influence his views in an area of science.

(b) A SITUATION SHOULD NOT BE INTERPRETED IN TERMS OF THE OBSERVER, BUT HIS ROLE SHOULD BE INTERPRETED REALISTICALLY IN TERMS OF THE SITUATION.

5. The processes by which scientists verify hypotheses.

a) The falsity of an alleged fact or theory in science can be determined, although the scientist cannot know whether the theory or fact is "true" in an absolute sense. FOR A SCIENTIFIC FACT OR THEORY TO BE ACCEPTED BY SCIENTISTS, IT MUST BE SHOWN TO BE NOT FALSIFIED BY EVIDENCE THAT HAS BEEN GATHERED.

(1) Science has selected, as its criteria for truth, sense data which can be comprehended and checked by everybody with appropriate training.

(a) If an alleged fact is false, it will be detected by multiple observations of the same phenomena by different persons. An alleged fact is accepted when multiple observations by different people concur.

(2) THE RELEVANCE AND VALIDITY OF THE CONSTRUCTS OF SCIENCE ARE DETERMINED BY THE THEORETICAL STRUCTURE OF SCIENCE.

b) A THEORY OR MODEL IS HELD TO BE VALID TO THE EXTENT THAT OBSERVATIONS CHECK WITH DEDUCTIONS DERIVED FROM IT. If observations do not check with predictions made from a theory or model, it may be held with restricted scope, or it may be discarded in favor of a more adequate theory.

(1) Principles are confirmed through their consequences (principles + operational definitions of terms = physical hypothesis).

(a) THE PRINCIPLES OF SCIENCE CAN BE VALID ONLY WHEN THEY REFER TO A SYSTEM, OR SYSTEMS, OF REFERENCE.

(2) TO BE OF VALUE AND INTEREST IN SCIENCE, A SCHEME MUST ALLOW PREDICTION OF A LARGE NUMBER OF APPARENTLY UNRELATED OBSERVATIONS.

(a) IF A SCIENTIFIC THEORY OR SOME PART OF IT IS FALSE, IT WILL PREDICT PHENOMENA THAT CANNOT BE FOUND THROUGH EXPERIMENTS OR OBSERVATIONS BY COMPETENT INVESTIGATORS.

(3) VARIOUS OPERATIONS, MATHEMATICAL CONVENIENCE, SIMPLICITY, AND COMMON SENSE PLAY A ROLE IN THE ACCEPTANCE OF CONCEPTS.

(4) SCIENCE ALONE IS UNABLE TO DECIDE ON THE VALIDITY OF THEORIES OF HIGH GENERALITY.

(5) SIMPLICITY, HEURISTIC POTENCY, AND GROWTH POTENTIAL ALL CONTRIBUTE TO THE VALIDITY OF A THEORY.

C. Science's "behaving" results in two types of scientific inquiry.

1. IF PROCESSES EMPLOYED ARE SUCCESSFUL IN RELIEVING STRAIN WITHOUT ALTERING STRUCTURE (refinement, completion, or improved articulation within existing structure) THE CHANGE IS SAID TO BE REVERSIBLE AND IS CHARACTERISTIC OF NORMAL, STABLE OR COMPLETIVE INQUIRY.

a) stable inquiry - "constructing an edifice without questioning the plan" (Schwab)

b) KNOWLEDGE IS CUMULATIVE IN THE SIMPLE SENSE OF ACCRETION.

2. Although a process may alleviate a local strain, it may also fail in this, or generate a more general strain. EXISTING STRUCTURE MAY BE INCAPABLE OF ASSIMILATING THESE STRAINS AND IRREVERSIBLE CHANGE (change which

results in modification of structure) RESULTS. SUCH CHANGE IS CHARACTERISTIC OF EXTRAORDINARY, FLUID, OR GENERATIVE INQUIRY.

- a) Since scientists are seeking explanations of natural phenomena in terms of abstract ideas, it is inevitable that DIFFERENT INTERPRETATIONS OF A GROUP OF PHENOMENA WILL ARISE. At such times, there will be disagreements and controversies among scientists about the interpretation which best fits the observations. SUCH CONTROVERSIES PROVIDE STIMULUS TO FURTHER RESEARCH, as scientists seek evidence to resolve the conflict.
- b) fluid inquiry - "a mode of investigation which rests on conceptual innovation, proceeds through uncertainty and failure, and eventuates in knowledge which is contingent, dubitable, and hard to come by." (Schwab)
- c) DISCOVERY IN FLUID INQUIRY IS PARTICULARLY DIFFICULT BECAUSE OF THE DUAL NATURE OF THE EVENT.
 - (1) SELECTION OF OBSERVABLES - Properties used to define states must be necessary and sufficient as determined by relations which mediate between them at all times.
 - (2) ESTABLISHMENT OF RELATIONS - expressed as logical or mathematical relations among the observables.
 - (3) observables cannot be selected without laws and laws cannot be formulated without observables, thus, THE TWO MUST BE DISCOVERED (invented) HAND-IN-HAND. THIS IS THE TASK FOR WHICH CREATIVE GENIUS IS NEEDED.
- d) SCIENTISTS CREATE INNOVATIVE THEORIES THROUGH USE OF ANALOGY, METAPHOR AND IMAGINATIVE BREAKS FROM THE CONSTRAINTS OF LANGUAGE AND LOGIC OF EXISTING THEORY.
- e) AS A NEW THEORY GAINS ACCEPTANCE IT HAS PROFOUND EFFECTS ON EXISTING THEORY.
 - (1) All parts of the existing structure must be re-examined.

- (a) Old theories may have to be modified or discarded.
 - (b) Laws must be reinterpreted in terms of the new theory.
 - (c) Previously rejected facts, laws and theories may now be incorporable.
 - (d) The correlative, heuristic and explanatory functions of the new theory must be explored.
 - (e) Reformulation and restructuring may be extensive.
- (2) ACCEPTANCE OF A NEW THEORY IS MUCH LIKE A CHANGE IN GESTALT IN WHICH THE ELEMENTS BEING INTERPRETED ARE CONSTANT BUT A SWITCH IN INTERPRETATION OCCURS REQUIRING ABANDONMENT OF THAT PREVIOUSLY HELD IN FAVOR OF ONE COMPLETELY DIFFERENT. LITERALLY, A NEW WORLD OPENS UP.

Alternate Learning Modes

In an individualized program of study, account should be taken of the fact that the way in which any one student learns most effectively is not the most effective learning mode for all students. Since mastery of the ideas or skills in a unit of learning is the desired outcome, the particular route through which a student achieves mastery is of secondary importance. In fact, our ignorance of the learning process is so great at present that we actually have no very clear or dependable notion about exactly how a learner masters an idea or skill. It seems reasonable, therefore, to make provisions for as many alternate routes toward mastery as is feasible, so that an individual may choose a learning mode which appears to be best suited for him.

In this unit, as in other units of the Science Knowledge System, several alternate learning modes are offered. The student, with assistance from his counsellor, selects one of these modes and carries out the learning activities designated in it. After completing his study, he takes the unit appraisal test to demonstrate the extent of his understanding of the ideas in the unit. If the test results indicate mastery, he proceeds to another unit of his program of learning. If he has not achieved mastery, additional study in the unit is indicated, for which a different learning mode may be selected. For Unit S1, the following three alternate learning modes have been designed.

S1 Mode A - Analytical Study

This mode centers on the analysis of reports of scientific research in order to bring out, discuss, and clarify the characteristics of each inquiry. Two kinds of materials are used: 1) the "Invitations to Enquiry" developed by Schwab, 2) series of original papers from different fields of science. Group discussions and interaction are employed in pursuing the analysis of the source materials. For details on the procedures and scope of this learning mode, see: Joseph J. Schwab, editor, Biology Teacher Handbook (John Wiley, New York, 1963), pp. 45-226; Joseph J. Schwab.

S1 Mode B - Inductive Study

In this mode, selected case histories, each concerning the development of a major scientific idea, are studied in order to induce generalizations about the nature of scientific inquiry which

are illustrated in the cases. The case histories are chosen from those available in two series: 1) the "Harvard Case Histories in Experimental Science" developed by Conant, 2) the "History of Science Cases" developed by Klopfer. The induction of generalizations from the samples of inquiry in the cases is facilitated through group discussions. For a fuller exposition of this learning mode, see: L.E. Klopfer, "The Teaching of Science and the History of Science," *Journal of Research in Science Teaching*, vol. 6, no. 1 (1968)

Sl Mode C - Didactic Study

Intended primarily for independent study, this learning mode consists of the reading of selected books in the philosophy of science. Students employing this mode may meet together informally from time to time to discuss and compare ideas found in the readings, but this is not necessary; the written words of the authors are the source of learning in this mode. Books on the reading list include:

- S. Toulmin, The Philosophy of Science: An Introduction (Hutchinson's, London, 1953).
- M. Walker, The Nature of Scientific Thought, (Prentice-Hall, Englewood Cliffs, N.J., 1963).
- M. Beckner, The Biological Way of Thought, (Columbia Univ. Press, New York, 1959).
- R. Harre', An Introduction to the Logic of the Sciences (Macmillan, London, 1960).
- E. Nagle, The Structure of Science (Harcourt, Brace and World, New York, 1961).
- T.S. Kuhn, The Structure of Scientific Revolutions (Univ. of Chicago Press, Chicago, 1962).
- J. H. Woodger, Biology and Language: An Introduction to the Methodology of the Biological Sciences (Cambridge Univ. Press, New York, 1952).
- P. G. Frank, Philosophy of Science: The Link Between Science and Philosophy (Prentice-Hall, Englewood Cliffs, N.J., 1951).

Unit S2 - Inquiry in Science

This unit is designed to develop the student's skills in using the processes of scientific inquiry. Competence in these skills is needed by the elementary-school teacher who will instruct in a science curriculum where the students are to learn the same process skills. The organization of the unit assumes that the most meaningful way of developing the desired competence is through the carrying-out of an actual scientific investigation. In this way, the learner not only uses the process skills, but also experiences the flavor, thrill and hardships of scientific inquiry.

Since very few students have previously carried out a scientific investigation, Unit S2 is required of almost all students, and no appraisal pretest for this unit is offered. (A student who has had an equivalent research experience may take the part 1 of the appraisal posttest to obtain credit for mastery of Unit S2.) Mastery of Unit S1, The Nature of Scientific Inquiry, is prerequisite for beginning work in Unit S2, so that the student may use the processes of scientific inquiry when he already understands their structural context. The investigation of the unit may be carried out in either of two alternate learning modes. The unit appraisal test consists of two parts: 1) laboratory performance tests of skill in selected processes, 2) preparation of a complete report of the investigation.

The skills to be developed in Unit S2 are specified in the outline which follows. The arrangement of the outline places the simpler skills first and proceeds to more complex skills, but the ordering of the outline does not imply that this is the sequence in which competence in the processes of scientific inquiry is to be attained.

S2.00 SKILL IN THE PROCESSES OF SCIENTIFIC INQUIRY

The student will

S2.01 OBSERVING

S2.011 Observe the properties of an object or situation by using all five senses.

S2.012 State the observations in quantitative terms whenever possible

S2.00 **SKILL IN THE PROCESSES OF SCIENTIFIC INQUIRY (cont.)**

The student will

S2.013 **Make observations which describe changes of properties of the object and describe the rate of these changes.**

S2.014 **Communicate accurately the results of observations.**

S2.02 **CLASSIFYING**

S2.021 **Identify and name properties of a set of objects which can be used as a basis for a single-stage classification.**

S2.022 **Construct one or more single-stage classifications of a set of objects.**

S2.023 **Construct a two or more stage classification of a set of objects.**

S2.024 **Use a classification system or key to identify a given object.**

S2.03 **USING NUMBER RELATIONS**

S2.031 **State a ratio as an ordered number pair and identify units of measure to associate with a ratio of two numbers.**

S2.032 **State the relationship between the process of measuring an angle and the process of measuring a length, area, or volume.**

S2.033 **Demonstrate use of scientific notation in working with small and large numbers.**

S2.00 SKILL IN THE PROCESSES OF SCIENTIFIC INQUIRY (cont.)

The student will

S2.04 MEASURING

- S2.041** Order objects from most to least (or least to most) of some property all the objects have in common, e.g., length, mass, volume, density.
- S2.042** Measure an object using an arbitrary unit.
- S2.043** Measure an object using standard units from the metric system.
- S2.044** Measure quantities which combine two or more standard units, e.g., centimeters per second, degrees Celsius per minute.
- S2.045** Estimate measurements of length, area, volume, temperature, and others using arbitrary or standard units.
- S2.046** Devise and use direct and indirect measurements.
- S2.047** Use various standard measurement scales applicable to different phenomena.

S2.05 PRESENTING DATA

- S2.051** Construct a bar or point graph of pairs of measurements.
- S2.052** Construct a data table showing sets of quantitative and/or qualitative observations.
- S2.053** Identify the controlled measurements and the uncontrolled measurements in a table or graph of data.
- S2.054** Name coordinates of points in two-dimensional graphs.
- S2.055** Describe in words the trend or trends shown by the curve in a graph.

S2.0 **SKILL IN THE PROCESS OF SCIENTIFIC INQUIRY (cont.)**

The student will

S2.06 **INFERRING**

S2.061 **Distinguish between an observation statement and an inference or interpretation statement.**

S2.062 **Identify observations which support an inference.**

S2.063 **Construct one or more inferences from a set of observations.**

S2.064 **Describe additional observations which would test alternative inferences based on a set of observations.**

S2.065 **Distinguish between inferences and broad working hypotheses.**

S2.066 **Construct a broad working hypothesis, given a set of observations and/or inferences.**

S2.07 **PREDICTING**

S2.071 **Use a graph to interpolate and extrapolate**

S2.072 **State predictions by interpolating between observed events.**

S2.073 **State predictions by extrapolating beyond the range of observed events.**

S2.074 **Carry out observations or/and experiments to test interpolated and extrapolated predictions.**

S2.075 **Order a set of predictions as to the degree of confidence that can be placed in them.**

S2.0 SKILL IN THE PROCESS OF SCIENTIFIC INQUIRY (cont.)

The student will

S2.08 TESTING HYPOTHESES

S2.081 Construct a test of a hypothesis derived from a set of observations and/or inferences.

S2.082 Construct a test of a hypothesis derived from a scientific principle or model (theory).

S2.083 Identify data from a test which support or do not support a hypothesis.

S2.084 Construct a revision of a hypothesis on the basis of data obtained from a test of the hypothesis.

S2.09 CONTROLLING VARIABLES

S2.091 Identify variables which may influence the behavior or the properties of a physical or biological system.

S2.092 Identify variables which are held constant, manipulated, or responding in an experiment.

S2.093 Describe an experiment using correctly the terms variable, constant variable, responding variable, and manipulated variable.

S2.094 Distinguish between conditions which hold a given variable constant and conditions which do not hold a variable constant.

S2.095 Construct a test to determine the effects of one or more variables on a responding variable.

S2.096 Identify, name, and test alternate variables which were not held constant and which may have influenced the responding variable in an experiment.

S2.0 **SKILL IN THE PROCESS OF SCIENTIFIC INQUIRY (cont.)**

The student will

S2.10 **INTERPRETING DATA**

- S2.101** Describe in a few oral or written sentences the information shown in a data table or graph.
- S2.102** Construct one or more inferences from a comparison of the information in two or more related tables of data or graphs.
- S2.103** Apply rules to determine the mean, mode, median, range, standard deviation, and frequency distribution of a set of data.
- S2.104** Use the mean, mode, median, range, standard deviation, and frequency distribution to describe data and construct predictions or inferences from this information.
- S2.105** Construct one or more inferences from pictorial data (diagrams or photographs)

S2.11 **DEFINING OPERATIONALLY**

- S2.111** Identify variables or words for which an operational definition is needed, given an inference, broad working hypothesis, model, question, graph, or data table.
- S2.112** Distinguish between operational definitions and non-operational definitions of the same object, event, or idea.
- S2.113** Construct an operational definition which adequately describes an activity, object, or property of an object in the context in which it is used.

S2.0 **SKILL IN THE PROCESS OF SCIENTIFIC INQUIRY (cont.)**

The student will

S2.12 **USING MODELS (THEORIES)**

- S2.121** Identify a model that is consistent with a set of observations and/or inferences.
- S2.122** Construct a hypothesis, inference, or observation based on a model.
- S2.123** Demonstrate the use of a model to explain a set of observations and/or inferences.
- S2.124** Construct a modification of a model, given the original model and a set of additional observations or experimental results.

S2.13 **REPORTING EXPERIMENTS**

- S2.131** Distinguish between a description of an experiment which has tested an inference or prediction, and one which has not.
- S2.132** Identify and name variables in an experiment which the experimenter failed to hold constant for the purpose of the experiment.
- S2.133** Construct alternate interpretations from those described in the report of an experiment.
- S2.134** Construct a report of an experiment that is sufficiently complete for another person to be able to replicate the experiment.

Alternate Learning Modes

To provide for varying degrees of independence of individual students, two learning modes are offered for conducting the investigation of Unit S2. (For the rationale for offering alternate learning modes, see the discussion in Unit S1.)

S2 Mode A - Directed Investigation

In this mode, the instructor specifies the problem to be investigated and the student's task is to find a solution. The problem should be one for which the solution is not known, or at least should be a significant variation or needed replication of an investigation that was made previously. The instructor also directs the student to the relevant literature on the problem and may suggest some initial procedures and techniques for the investigation. Thereafter, he is available as a consultant as the investigation proceeds. The student maintains a chronological record of the progress of the investigation, including both his ideas related to the problem and data he obtains in experiments. When his work is completed, he prepares a full report of his investigation.

S2 Mode B - Undirected Investigation

The problem investigated in this mode is identified and defined by the student. The problem may be generated through the student's interest in a particular area of the biological or physical sciences and/or through a investigation, maintenance of the chronological record, and preparation of the report are the same as in S2 Mode A.

Unit S3 - Major Ideas of Science

Comprehension of important concepts, principles, and conceptual schemes of science is the aim of this unit. Through his study in Unit S3, the student gains the essential background he needs for teaching elementary-school science. Since no amount of study can encompass in detail the vast domain of scientific knowledge and ideas, the direction of study in this unit is toward the establishment of conceptual high points in the fabric of science. Having command of these high points, the teacher can consult available sources of supporting information to supply the specifics for a particular subject-matter topic when it is needed.

In the organization of this unit, it is assumed that a competent scientist can best determine what the most important concepts and principles in his field are, and that when these are taken together, they represent the major ideas of science. The scope of ideas included in the unit is indicated by the list of lecture subjects under Learning Mode A. The depth of treatment of the ideas is suggested by the kinds of books listed under Learning Mode B. Comprehension of the ideas at the level of the informed layman (--teachers are not scientists and should not be expected to have a scientist's understanding of an idea -) is assessed by the appraisal test for the unit.

Alternate Learning Modes

(cf. the discussion of alternate learning modes in Unit S1.)

S3 Mode A - Lecture Series

The student who selects this mode learns through listening to a series of lectures, the best available, on the major ideas in various fields of science. A competent scientist prepares one to three lectures highlighting the major ideas in his own field. He delivers his lecture or lectures to a live student audience, but the lecture is also videotaped for later independent viewing by students. Eventually most of the lectures of the series will be in the videotape library, where they can be accessible to students at any time. Substitutions in the videotape library are made when better lectures on the major ideas in a field become available. The lecture subjects in the series include:

- Motion
- Forces in Nature
- Conservation of Energy
- Electricity and Magnetism
- Light and Electromagnetic Radiations
- Atomic Structure
- Chemical Change
- Chemical Equilibrium
- Carbon
- Thermodynamics
- Quanta
- Relativity
- Stars and Galaxies
- The Earth in Space
- Geophysics
- Geochemistry
- (Biography of the Earth)
- Origin of Life

Cell Structure and Function
Cellular Physiology and Biochemistry
Development
Heredity and Genetics
Evolution
Plant Life
Plant Diversification
The Green Plant
Animal Structure and Function
Animal Adaptation
Animal Physiology
Animal Behavior
Microbial Life
Ecology
Reliable Reference Sources - Physical Sciences
Reliable Reference Sources - Biological Sciences

S3 Mode B - Significant Books

This mode is modeled on the well-known "Great Books Discussions." The student reads the books suggested on the reading list and then meets regularly with other students in a small group to discuss the ideas presented in the reading. A discussion leader provides leading questions as a focus for each group meeting. The significant books to be read and discussed include:

- V. Weiskopf, Knowledge and Wonder
- G. Murchie, Music of the Spheres: The Material World from Atom to Quasars
- G. Gamow, Matter, Earth, and Sky
- T. Bonner, The Ideas of Biology
- E. Borek, The Atoms Within Us
- M. Bates, The Forest and the Sea
- G. and M. Beadle, The Language of Life
- M. Born, The Restless Universe
- B.C. Saunders and R.E.D. Clark, Order and Chaos in the World of Atoms

- H. Bondi, Relativity and Common Sense
- F. Hoyle, The Nature of the Universe
- A. Ihde, The Development of Modern Chemistry
- J. F. Sandfort, Heat Engines
- (J. A. Mazzeo, The Design of Life)
- L. Eesley, The Firmament of Time
- D. J. Ingle, Life and Disease
- H.H. Ross, A synthesis of Evolutionary Theory

S3 Mode C - Combined Mode

If a student elects this mode, he does part of his study in the unit through one mode and part through the other mode. For example, a student who has never taken a systematic course in science may be recommended to take one or two such courses (Mode C), but he may also study in Mode A and/or Mode B. Other mode combinations are possible under Mode D, and the student, with counselling, may order his learning modes for this unit in the way best suited to him.

Unit S4 - Social Aspects of Science

The purpose of this unit is to develop the prospective teacher's understanding of the social aspects of science, which are an important component of the new elementary-school science curriculum. The social aspects of science refer primarily to the interactions of science and the larger society in which it flourishes, but they also include the interrelationship of functions within the scientific enterprise itself.

The understanding to be developed in this unit is defined by the set of ideas concerning the social aspects of science that are outlined below. This outline results from a functional and compositionist analysis of science in its interaction with other comparable levels of organization and with higher levels of organization. Science, from this point of view, is a complex system which interacts with its external and internal environments. This system, like all systems, exhibits becoming, being, and behaving. As in the outline for the ideas in Unit S1 (g.v.), these have been used as the major categories for the outline of ideas in this unit.

IDEAS CONCERNING THE SOCIAL ASPECTS OF SCIENCE

I. General

A. Definition - SCIENCE IS MODERN MAN'S PRINCIPAL AND MOST SUCCESSFUL MEANS OF ADAPTING TO HIS ENVIRONMENT.

1. THE VIEW THAT THE UNIVERSE IS RATIONAL IS SIGNIFICANT FOR MAN'S ADAPTATION.
2. THE PROCESSES OF INQUIRY MAKE SCIENCE A UNIQUE ENTERPRISE.

II. Becoming - the socio-historical development of science

1. HUMAN THOUGHT HAS CHANGED RADICALLY SINCE MEDIEVAL TIMES.

- a) MODERN SCIENCE IS A PRODUCT OF THIS CHANGE.
- b) SCIENCE HAS ACCELERATED AND INTENSIFIED THIS CHANGE.
- c) CERTAIN HISTORICAL AND PHILOSOPHICAL DEVELOPMENTS HAVE INFLUENCED SCIENTIFIC THOUGHT.

2. MODERN SCIENCE IS A RECENT DEVELOPMENT.

3. OUR WORLD IS BEING CHANGED THROUGH SCIENTIFIC DISCOVERY.

4. SCIENTISTS EXPECT A RAPID TURNOVER OF KNOWLEDGE.

- a) WHEN A CONCEPT OR THEORY IS FOUND NOT TO CONFORM WITH OBSERVATION OR EXPERIENCE THE CONCEPT OR THEORY MUST BE MODIFIED OR REPLACED TO BRING IT INTO ACCORD.
- b) AT PRESENT, THE IDEAS IN MANY AREAS OF SCIENCE ARE CHANGING RAPIDLY.

5. SCIENCE IS NOT, AND PROBABLY WILL NEVER BE, A FINISHED ENTERPRISE; THERE REMAINS ALWAYS MORE TO DISCOVER.

6. AS CIVILIZED MAN'S PRINCIPAL MEANS OF BIOLOGICAL ADAPTATION, SCIENCE IS AN EVOLUTIONARY SPECIALIZATION THAT AROSE FROM MORE PRIMITIVE, PRESCIENTIFIC MEANS OF CULTURAL ADAPTATION, WHICH IN TURN HAD ARISEN FROM STILL MORE PRIMITIVE, PREHUMAN BEHAVIORAL ADAPTATION.

III. Being - the interlocking web of responsibilities involving science, scientists and society

A. Science and the Humanities

1. The study of science in our schools is carried on without regard for the humanities and the study of the humanities is carried on without regard to science; yet EACH IS COMPLEMENTARY TO THE OTHER.

a) SCIENCE IS AMONG OTHER INTELLECTUAL AND ESTHETIC PURSUITS: THE SCIENCES ARE THEMSELVES A HUMANISTIC ENTERPRISE, AS MUCH AS LITERATURE, THE ARTS, HISTORY AND RELIGION CONNECTED CLOSELY WITH EVEN WHILE DIFFERING FROM THEM.

(1) Work in the philosophy of science, in contrast to the work of science, is devoted to providing a system of concepts and laws within which science, philosophy, and the humanities can fit.

(2) THE GROWTH OF MODERN SCIENCE STEMS FROM MAN'S COMPELLING DESIRE TO UNDERSTAND HIMSELF AND HIS ENVIRONMENT.

2. Stereotypes - what science and scientists are and are not

a) The educated layman must understand that science is not technology, it is not gadgetry, it is not some mysterious cult, it is not a great mechanical monster. SCIENCE IS AN ADVENTURE OF THE HUMAN SPIRIT.

(1) SCIENCE IS NOT MAGIC: scientists seek to explain phenomena while magicians seek to mystify and entertain and to make explanation difficult.

(2) Technology is not the same as science: TECHNOLOGY INVOLVES THE MEANS OF BUILDING AND DOING USEFUL THINGS; THE AIM OF SCIENCE IS THE DEVELOPMENT OF KNOWLEDGE.

- (a) The boundary lines between technology and applied science and science (sometimes called "pure science") and between technology and science are not always clear.
- (b) INVENTORS AND DESIGNERS OF USEFUL DEVICES ARE NOT SCIENTISTS, EVEN THOUGH THE MAKING OF A DEVICE (or machine) FREQUENTLY RESULTS FROM THE APPLICATION OF SCIENTIFIC KNOWLEDGE.
- (3) SCIENTISTS DO NOT CLAIM THAT THEIR THEORIES DESCRIBE AN "ULTIMATE REALITY."

b) Scientists as people

- (1) MEN AND WOMEN WITH A VARIETY OF PERSONALITY TYPES CARRY OUT THE DIVERSE TASKS IN SCIENCE.
- (2) THERE IS LITTLE FACTUAL BASIS FOR SOME OF THE POPULAR STEREOTYPES OF SCIENTISTS.
- (3) MANY GENERALIZATIONS ABOUT SCIENTISTS ARE TENDENCIES OF SUCCESSFUL PROFESSIONAL PEOPLE IN GENERAL (e.g., DEDICATION TO HIS OR HER WORK, EXTREMELY HARD-WORKING).
- (4) AS A GROUP, SCIENTISTS ARE ABOVE-AVERAGE IN GENERAL INTELLIGENCE.
- (5) Scientists do not necessarily display "scientific attitudes" when they are not engaged in their work. As human beings, SCIENTISTS ARE SUBJECT TO THE SAME HUMAN WEAKNESSES, TEMPTATIONS, AND EMOTIONS AS ARE PEOPLE IN OTHER LINES OF WORK.

B. Responsibilities of Society to Science and Scientist

- 1. PUBLIC UNDERSTANDING OF THE DIFFERENCE BETWEEN THE SHORT AND LONG RUN PURPOSES OF SCIENCE AND TECHNOLOGY IS ESSENTIAL TO ADVANCING OUR SCIENCE AND SOCIETY.
 - a) DISCIPLINED JUDGMENT ON MANY CONTEMPORARY SOCIAL, ECONOMIC, AND POLITICAL PROBLEMS EXISTS ONLY IN THE CONTEXT OF SCIENCE AND TECHNOLOGY.
 - (1) THE ABILITY TO GENERATE NEW KNOWLEDGE IN SCIENCE AND APPLY IT IN TECHNOLOGY IS THE NEW ECONOMIC DENOMINATOR IN TODAY'S WORLD.

- (2) SCIENCE HAS POTENTIALITIES AND LIMITATIONS IN SOLVING SOCIETAL PROBLEMS SUCH AS DISEASE, STARVATION, DEFENSE AND INSUFFICIENCIES IN RAW MATERIALS.
- b) PROPER APPLICATION OF DISCOVERY IS THE DOMAIN OF THE SOCIETY-AT-LARGE.
 - (1) NO ONE COUNTRY, CORPORATION, GROUP OR PERSON HAS THE "RIGHT" TO A DISCOVERY.
- 2. SCIENCE IS NOT ISOLATED FROM BUT IS TO A LARGE DEGREE A PRODUCT OF THE CULTURE IN WHICH IT EXISTS.
 - a) CERTAIN SOCIAL, POLITICAL, AND ECONOMIC CONTEXTS ARE ESSENTIAL TO MAINTAINING THE INTEGRITY OF SCIENCE.
 - (1) MONEY IS NEEDED IN SCIENCE FOR SALARIES AND FOR MATERIALS AND EQUIPMENT to carry out research projects, small or large. The cost of complex, large-scale, or long-range investigations is sometimes great.
 - (a) Scientists doing research require specialized instruments and equipment to carry out experiments and make observations. As experiments become more precise and sophisticated, improvements must be made in the scientific instruments and equipment employed.
 - (b) Instruments and equipment used by scientists are generally made and furnished by non-scientists.
 - (2) FREEDOM OF INQUIRY AND COMMUNICATION AND AN ADEQUATE SUPPLY OF WELL EDUCATED MANPOWER ARE ESSENTIAL TO THE ADVANCEMENT OF THE SCIENTIFIC ENDEAVOR.
 - (a) Secrecy requirements imposed by industrial and governmental establishments are not in the best interest of science.

(3) SCIENCE IS INTERNATIONAL IN SCOPE, WITH SCIENTISTS COLLABORATING IN THEIR EFFORTS ON AN INTERNATIONAL SCALE.

(a) Validation of ideas is an international endeavor: there is no room for nationalism in science.

(b) The origin of a contributor is unimportant -- it is the contribution that counts.

C. Responsibilities of Science to Scientists and Society.

1. TO PROVIDE FOR SCIENTISTS AND FUTURE SCIENTISTS:

a) SCIENTIFIC SOCIETIES

(1) Scientific societies and associations are the professional organizations of scientists. They promote the progress of science through their various activities and functions.

(2) Nature of scientific societies: most are voluntary associations of scientists working in a particular field; some are sponsored by national governments; a few very large associations join together scientists from many specialized fields.

b) SCIENTIFIC JOURNALS: highly specialized publications which report current experimental and theoretical work; not designed for "popular" reading; serve, in part, as a forum for discussing ideas in a particular scientific field; often sponsored by scientific societies; thousands of journals are published in many countries to serve various scientific specialists; scientific journals usually carry little or no advertising and are, therefore, relatively expensive; there are also special technological journals, which contain articles more concerned with practical applications and usually carry industrial advertising; because of the tremendous and continually-increasing volume of publications, there are also special abstracting journals, which contain brief accounts of recent articles in a field of science that have been published in many other journals.

- c) **HELP FOR THE PUPIL WHO HAS ALREADY CHOSEN TO BECOME A SCIENTIST, TECHNICIAN, OR ENGINEER to comprehend the humanistic basis and significance of his life-speciality; and to overcome the ever-present danger that we may, in our schools and colleges produce a specialized and narrow-minded technician, whether in the research laboratory or in the machine shop or at the factory bench, and to teach him humility in his role as scientist, serving, not dominating society.**
- 2. **PROVIDE FOR SOCIETY NOT ONLY KNOWLEDGE BUT A PARADIGM FOR GROWTH**
 - a) **THE VALUE OF SCIENCE LIES NOT IN THE SUBJECT MATTER ALONE BUT CHIEFLY IN THE SPIRIT AND LIVING TRADITION IN WHICH THE DISCIPLINES ARE PURSUED.**
 - 3. **TO PROVIDE FOR SCIENTIST-TO-BE AND SOCIETY-AT-LARGE:**
 - a) **ENTHUSIASM FOR THE INTRINSIC DELIGHTS OF SCIENTIFIC KNOWLEDGE, in part because it will make life enjoyable, in part because society has an extreme need of good scientists in every field of human difficulty.**
 - b) **RICH AND VARIED EXPERIENCES OF INDIVIDUAL THINKING AND CRITICAL ATTITUDES ON THE ONE HAND, AND OF COOPERATIVE ENTERPRISE AND MUTUAL AID ON THE OTHER.**
- D. Responsibilities of Scientists to Society and Science**
- 1. **The social responsibilities of scientists**
 - a) **TO EDUCATE OUR STUDENTS so that they may distinguish ends from means, probabilities from certainties, evidence from propaganda, questions from pseudo-questions, rational belief from superstition, and science from quackery**
 - (1) **UNDERSTANDING THE INTERACTION OF SCIENCE AND SOCIETY IS ESSENTIAL TO PARTICIPATION IN THE INTELLECTUAL LIFE OF THE PRESENT AND FUTURE.**
 - b) **TO BRING ABOUT A WIDER APPRECIATION OF THE ETHICAL IMPLICATIONS OF SCIENCE FOR THE COMMON GOOD**

- (1) to appreciate the communality of scientific knowledge
- (2) to recognize that the fruits of the scientific endeavor are part of the public trust
- c) TO UNDERSTAND THE IMPACT OF SCIENCE AND TECHNOLOGY ON MODERN SOCIETY AND ITS ATTENDANT PROBLEMS
 - (1) to help the citizen investigate ways of increasing the range and depth of understanding natural processes and to relate this problem of encouraging and exploiting science to the many puzzling complexities of industrial society
 - (a) to recognize man's ability and potential to regulate his environment
 - (b) to be aware of the limitations of science
 - (c) to offer rational opinions when making social and moral decisions

2. Responsibilities of the scientist to science

- a) TO APPRECIATE THAT EMOTIONAL NEUTRALITY IS IMPORTANT IN MAKING SCIENTIFIC JUDGMENTS
- b) TO REALIZE THAT VALIDITY OF THE IDEA, RATHER THAN THE AUTHORITY OF THE ORIGINATOR, IS THE CRITERION OF ACCEPTABILITY
- c) TO APPRECIATE THAT PUBLICATION OF DISCOVERY IS ESSENTIAL TO SCIENTIFIC ADVANCEMENT
 - (1) to realize that scientific journals present results of investigations and discuss the validity of ideas on the basis of evidence rather than emotions
- d) TO RECOGNIZE THAT THE AIM OF PURE SCIENCE IS TO INCREASE MAN'S KNOWLEDGE OF THE PHYSICAL AND BIOLOGICAL WORLD WITHOUT RESPECT TO ANY PRESENT OR FUTURE GOOD OR EVIL.

3. Responsibilities of the scientist to both science and society.

- a) TO UNDERSTAND AND APPRECIATE THE SOCIAL AND CULTURAL RELATIONSHIPS OF SCIENCE
 - (1) to become aware of the ethos of modern science
 - (2) to recognize the limitations of scientific knowledge
- b) TO UNDERSTAND THAT SCIENTISTS SEEK UNDERSTANDING OF THE UNIVERSE AND BETTERMENT OF MAN'S ESTATE, RATHER THAN PERSONAL GAIN
 - (1) to realize that recognition for having made a discovery is, in itself, a reward
 - (2) to realize that new discoveries are made public and immediately tested by the peers of the discoverer
- c) TO HELP IN THE ENLISTMENT OF ADEQUATE SCIENTIFIC MANPOWER THROUGH CONCERN FOR EDUCATION
- d) TO STRIVE TO CLOSE THE GAP BETWEEN PUBLIC KNOWLEDGE AND THE FRONTIERS OF INQUIRY
- e) TO UNDERSTAND THAT IT IS THE RESPONSIBILITY OF THE SCIENTIST TO BE ABLE TO INTERPRET THE CONSEQUENCES OF HIS WORK FOR MAN'S COMMON-SENSE VIEW OF THE WORLD.
- f) TO HELP THE PUPIL TO UNDERSTAND THE POSITION OF HIS FUTURE JOB OR ACTIVITY IN THE PRODUCTIVE WEB OF SOCIETY AS A WHOLE, TECHNICALLY AND SCIENTIFICALLY AND SCIENTIFICALLY AS WELL AS SOCIALLY, SO AS TO ESTABLISH HIS SANE AND HEALTHY SELF-KNOWLEDGE AND SO THAT HE MAY ACT MORE INTELLIGENTLY WITH OTHERS WHENEVER THERE ARE JOINT UNDERTAKINGS.

IV. Behaving - THE INTERACTIONS OF SCIENCE WITH SOCIETY-AT-LARGE ARE RECIPROCAL: SCIENCE HAS MARKED INFLUENCES ON THE CULTURE IN WHICH IT EXISTS: AT THE SAME TIME, THE CULTURAL ENVIRONMENT OF THE SOCIETY-AT-LARGE INFLUENCES THE DEVELOPMENT OF SCIENCE.

A. Social influences on science and scientists

1. SCIENCE IS, IN LARGE MEASURE, A PRODUCT OF THE PREVAILING CULTURE OF THE SOCIETY IN WHICH IT EXISTS.

a) Factors which determine how well science will flourish in a particular society include:

(1) the conduciveness of the general climate of opinion to the kind of inquiry which scientists pursue:

(2) the maintenance of an adequate educational system to train scientific investigators and supporting personnel;

(3) the provision of sufficient financial backing for science personnel, materials and institutions;

(a) Today national governments and large industrial organizations frequently finance research in science. Unfortunately, most government research funds are committed to research on technological applications, while a relatively small amount goes into scientific research.

(4) the state of development of supporting industries which supply instruments, equipment, and materials needed in scientific work

(a) Technology contributes tools and, frequently, questions to basic science.

(b) Introduction of a new instrument or technique may lead to a new epoch of scientific progress. A new instrument or technique lets the scientist see (literally and figuratively) more than he did before and thereby frequently makes possible a new line of investigation.

- b) Since the factors mentioned in paragraph a) vary from country to country and from time to time, the extent of scientific activity and achievements vary from one nation to another and throughout the history of any one nation.

2. Social influences on scientists

- a) A CONFLICT MAY ARISE BETWEEN A SELF-SEEKING SOCIETY AND THE SCIENTIST.
- b) DIVISION OF LABOR AND SPECIALIZATION IN OUR SOCIETY MAKE IT IMPOSSIBLE FOR AN INVESTIGATOR TO GUARD HIS DISCOVERIES FROM IMPROPER APPLICATION.
- c) ORIGINALITY, AS EXEMPLIFIED BY PRIORITY OF DISCOVERY, IS VALUED BY SCIENTISTS.

3. Influence of society on both science and scientists

- a) THE NEEDS AND INTERESTS OF A SOCIETY OFTEN INFLUENCE THE KINDS OF PROBLEMS THAT ARE INVESTIGATED.
- b) THE SEPARATION BETWEEN SCIENCE AND TECHNOLOGY IS BECOMING VERY SMALL AND, IN SOME FIELDS, IS RELATIVELY NONEXISTENT.
- c) INSTRUMENTS EXTEND MAN'S SENSES AND MAKE IT POSSIBLE TO EXPLORE NEW AREAS OF INVESTIGATION.
- d) SECRECY CAN ONLY INHIBIT SCIENTIFIC PROGRESS.

B. Influence of science on scientists and society

1. Institutional pressures on scientists

- a) Many of the noble characteristics attributed to scientists are more a reflection of the nature of the scientific enterprise than of the personalities of scientists. WHAT ARE GENERALLY KNOWN AS "SCIENTIFIC ATTITUDES" ARE PERHAPS BETTER DESCRIBED AS PROFESSIONAL STANDARDS. The nature of scientific evidence is such that observations and experiments can almost always be checked or duplicated by other scientists, so that frauds and sloppy operators are rapidly detected. In the laboratory, therefore, the scientist will be

as accurate, honest, self-critical, and open-minded as he possible can. If he isn't, he will soon lose the respect of his colleagues.

- (1) IDEAS ARE RETAINED ONLY AS LONG AS THEY ARE VALID.
 - (2) A SCIENTIST EXPECTS HIS IDEAS TO BE CHALLENGED.
 - (3) CAREFUL VALIDATION OF IDEAS MAKES IT POSSIBLE FOR RESEARCHERS TO BUILD ON PREVIOUS WORK WITH CONSIDERABLE CONFIDENCE.
 - (4) VALIDATION OF IDEAS ELIMINATES QUACKS AND CHARLATANS FROM SCIENTIFIC WORK.
- b) ANOTHER INSTITUTIONAL PRESSURE ON SCIENTISTS IS TO BE CREATIVE. The scientist cannot be merely a recorder of observations, for a large task in science is the development of new ways of thinking about what is observed and new techniques for observing. Thus, a definite creative effort is demanded of the scientist. This demand accounts for the appearance of certain personality tendencies among scientists, since creativity is a function of certain personality attributes, and non-creative people do not stay active as scientists. Many attributes which have been frequently observed among scientists as they work are those needed in other creative fields as well. Examples are:
- (1) patience
 - (2) perseverance
 - (3) dedication to work
 - (4) imagination
- c) CONTROVERSIES IN SCIENCE ARE RESOLVED IN THE OPEN FORUM (either in meetings or through publications) OF THE PROFESSIONAL GROUP. A scientist's views are always subjected to the informed criticism of his colleagues, and it is expected that he should present all relevant evidence, appeal to experimental and observational data, and rely on logic, not rhetoric.

- (1) Scientists communicate with one another through meetings, journals, books, personal contacts, correspondence. Informal and formal contacts among scientists are equal in importance. Ideas, opinions, and speculations are clarified and grow through informal give-and-take, letters, discussions. Publications make it possible for a scientist's work to be critically scrutinized by his colleagues and to be subject to repeated tests.

2. Influences of modern science on society

- a) THE EVOLUTION OF SCIENTIFIC IDEAS AND SCIENTISTS' ACHIEVEMENTS IN UNDERSTANDING THE NATURAL WORLD HAVE GREATLY AFFECTED, AND WILL CONTINUE TO AFFECT, THE CONDITIONS OF PEOPLE IN A SOCIETY:

- (1) The influence of scientific ideas on human thought are reflected in changes in orientation and in the content of literature and philosophy.

- (a) Science makes contributions to man's common-sense view of the world.

- (2) Applications of scientific laws and principles accelerate, and often make possible the development of an efficient technology. Expanding technology, in turn, produces many economic readjustments and opportunities with their concomitant sociological changes.

- (a) Increased population, "automated unemployment," and nuclear-phobia are only a few of the societal problems created by science and technology.

- (b) There are vocational and leisure implications of scientific discovery and technological development.

(3) Applications of scientific ideas to problems of human health and disease help to alleviate people's suffering and often produce significant changes in demographic characteristics of society.

(a) Innovation in science and technology may rearrange political relations and the world balance of power.

(b) SOCIAL AND ECONOMIC INVENTIONS MAY BE NECESSARY TO KEEP PACE WITH AND TO ENHANCE SCIENTIFIC AND TECHNOLOGICAL DEVELOPMENT.

3. Influence of science on both scientists and society

a) TODAY, SCIENTIFIC RESEARCH IS SUFFICIENTLY COMPLEX TO NECESSITATE LONG YEARS OF TRAINING FOR MOST TYPES OF WORK. This training usually includes several years of study after graduation from college. Although formal graduate work is not a sufficient condition for creative scientific accomplishments, it is usually necessary in order to secure employment as a scientist. The "gentleman scientist" is essentially a phenomenon of the past.

b) THE DIFFICULTIES IN COMMUNICATION FOSTERED BY THE EXPLOSION OF SCIENTIFIC KNOWLEDGE ARE BECOMING PROHIBITIVE.

C. Influence of scientists on science and society

1. Influence of scientists on science

a) BELIEF IN ORDER AND UNITY MOTIVATES THE SEARCH FOR REGULARITIES AND REPRODUCIBILITY OF PHENOMENA.

b) SCIENTIFIC CONCEPTS AND THEORIES BEAR THE IMPRINT ON THE MAN WHO CREATED THEM AND INVOLVE HIS PERSONALITY.

2. Influence of scientists on science and society

a) THE INTERACTION BETWEEN THE SOCIAL AND INTELLECTUAL VALUES OF THE SCIENTIST PRODUCES THE DEVELOPMENTS OF SCIENCE AND TECHNOLOGY.

(1) At different times, the activities of an individual scientist may contribute to science, applied science or technology.

b) A scientist may offer biased opinions when operating outside of his area of specialization.

4

Alternate Learning Modes

(cf. the discussion of alternate learning modes in Unit S1.)

S4 Mode A - Group Inquiry

In this mode, various problems related to the interactions of science and society are explored in a seminar format. Stimuli for the group's inquiries are contemporary articles in magazines and newspapers. The points of view expressed by the authors of the articles are analyzed and related to more general ideas concerning the social aspects of science. Areas and topics which are discussed include:

1. Science, Technology, and Society
 - a. The Race into Space
 - b. Food Supplies for Tomorrow
 - c. Energy Resources for a Technological Nation
 - d. Pollution of the Environment
 - e. Waste of Natural Resources
 - f. Nuclear Warfare
 - g. Man and the Computer
 - h. Effects of Technological Progress on Human Behavior
2. Science and Social Problems
 - a. The Population Explosion
 - b. Control of Disease
 - c. Genetic Manipulation of Life
 - d. Automation
 - e. Views of Prominent Scientists on Contemporary World Problems
 - f. Science and Political Systems
 - g. Science and the Federal Government in the United States
3. Science and the Humanities
 - a. Impact of Science in Literature
 - b. The Scientist in Fiction
 - c. Science and the Poet
 - d. Impact of Science in Art
 - e. Architecture: Scientific or Artistic?
 - f. Science and Music

4. Science and Philosophy

- a. Expanding Conceptions of the Universe
- b. Effects of Scientific Inquiry on Philosophic Thought
- c. Impact of Scientific Thought on Theology

S4 Mode B - Individual Inquiry

This learning mode consists of the reading of selected books dealing with the social aspects of science. Students electing this mode may sometimes meet together informally to discuss and compare ideas found in the readings, but the emphasis of this mode is the individual's independent inquiry. Books on the reading list include:

- | | |
|--------------------|---|
| J. Bronowski, | <u>Science and Human Values</u> |
| C. P. Snow, | <u>The Two Cultures and the Scientific Revolution</u> |
| B. Barber, | <u>Science and the Social Order</u> |
| O. K. Price, | <u>The Scientific Estate</u> |
| B. Russell, | <u>The Impact of Science on Society</u> |
| J. B. Conant, | <u>Modern Science and Modern Man</u> |
| G. Piel, | <u>Science in the Cause of Man</u> |
| J. D. Bernal, | <u>The Social Function of Science</u> |
| W. S. Beck, | <u>Modern Science and the Nature of Life</u> |
| R. Cruber, | <u>Science and the New Nations</u> |
| L. Leoy, | <u>Space: Its Impact on Man and Society</u> |
| G. R. Harrison, | <u>The Role of Science in Our Modern World</u> |
| M. Nichalson, | <u>Science and the Imagination</u> |
| J. R. Oppenheimer, | <u>Science and the Common Understanding</u> |

Unit S5 - Science and Children

The two foci of this unit are 1) the learning capacities and behaviors of children as they relate to their science learning, and 2) special considerations and techniques which apply to science instruction. Coming after the student has entered the education sequence of the Teacher Education Program, the student's study in Unit S5 is supported by his study in other units dealing with educational psychology, classroom management, and philosophy of education. The overall intent of the unit is to explore the interconnections between the science curriculum's content, which is the concern of Units S1 through S4, and the children who study science in the elementary school.

The competence which the prospective teacher is to develop through Unit S5 is specified in the outline below. In comparison with other units in the Science Knowledge System, the outcomes expected from work in this unit are much fewer, so that the student will probably spend a comparatively short duration of time in study here. Mastery of Unit S5 leads directly into the practicum experience of Unit S6, which provides the opportunity for application of the student's insights concerning science and children.

S5.00 COMPETENCE CONCERNING SCIENCE AND CHILDREN

The prospective teacher of elementary school science will

5.1 CHILDREN

- 5.11 Recognize the great variety of individual differences in students, e.g., intelligence, creativity, social and cultural background, interests; and the implications of such differences for their learning of science.
- 5.12 Be familiar with the patterns of thought generally characteristic of students at their different developmental levels and the relationship between these patterns and the kind of science students can study profitably.
- 5.13 Be aware of the wide range of behaviors which any individual student studying science can be expected to display.

S.5.00 COMPETENCE CONCERNING SCIENCE AND CHILDREN (cont.)

The prospective teacher of elementary school science will

- S5.14 Realize that there are differences in frustration and tolerance levels among students and that these differences have implications for their learning of science.
- S5.15 Understand that science learning can be of different kinds, e.g., cognitive, affective, kinesthetic; and that each of these requires appropriate learning experiences for the student.
- S5.16 Identify teaching behaviors and programs most likely to elicit attitudinal and value learning in students.
- S5.17 Distinguish convergent from divergent thought processes and the conditions for eliciting and reinforcing each in science teaching.
- S5.2 SCIENCE INSTRUCTION
- S5.21 Formulate a statement to which he is committed regarding the purpose for the teaching of science in the elementary school.
- S5.22 Develop procedures for the teaching of science which encourage autonomous inquiry by students.
- S5.23 Develop ways for specific utilization in his teaching of both the processes and products of scientific inquiry.
- S5.24 Understand the planning and use of appropriate classroom and laboratory management techniques.
- S5.25 Realize the need for various types of general instructional materials and specialized materials for science instruction.

S5.00 COMPETENCE CONCERNING SCIENCE AND CHILDREN (cont.)

The prospective teacher of elementary school science will

- S5.26 Be able to apply suitable criteria for the selection of general instructional materials and specialized materials for science instruction.
- S5.27 Be aware of the technological resources available to teachers, e.g., programmed textbooks, teaching machines, audio-visual aids, and resources unique in science instruction.
- S5.28 Be familiar with the sources of printed materials for reference and supplementary use, particularly as they apply to the teaching of science.
- S5.29 Be aware of safety practices appropriate to science teaching.

Alternate Learning Modes

The two alternate modes offered for this unit are greatly different from each other, and a written unit pretest is probably appropriate only for S5 Mode A. The unit posttest should be supplemented for students electing S5 Mode B. (For the rationale of alternate learning modes, see the discussion in Unit S1.)

S5 Mode A - Reading and Discussion

This mode essentially follows the format of the usual "Science Methods" course. Readings selected from standard textbooks designed for such courses are discussed in group meetings. Findings of relevant psychological and educational research studies are also discussed. (See the "What Research Says to the Teacher" series, prepared by the N.E.A. Department of Classroom Teachers and the American Educational Research Association, especially No. 12, Science in the Elementary School by Gerald S. Craig.) The student also examines a variety of science learning materials and assesses their appropriateness for children's study of science at different levels in the elementary school.

S5 Mode B - Investigation

This mode is similar in execution to the investigation in Unit S2 Mode B, but the subject investigated is different. The investigator here formulates a hypothesis concerning children's science learning and designs a modest experimental study to test the hypothesis. In doing so, he must become acquainted with what is known about children's science learning, with other research studies related to the problem being investigated, and with the design and analysis of an educational experiment. Upon completion of the investigation, he prepares a report that meets criteria of acceptability for this type of research. The actual experimental testing of the hypothesis may be carried out in conjunction with the practicum in Unit S6.

Unit S6 - Science Instruction

This unit is a practicum experience in the teaching of elementary-school science. The Unit S6 practicum for each student in the Teacher Education program has a duration of two to three weeks and takes place in the Clinical Setting. The unit provides the student, in the role of tutor or student teacher, with the opportunity to put into practice his combined insights about science and children's learning.

It must be emphasized that Unit S6 is a part of the prospective teacher's experiences in working with children in instructional situations and is set in the context of these other experiences. Hence, the comments elsewhere in this report regarding the functions, organization, and procedures of clinical experiences apply also to this practicum. The singular contribution of Unit S6 is that the subject matter taught here is in the area of science and that the teaching is directed toward the children's process of intellectual discovery - the hallmark of the new elementary-school curriculum.

Satisfactory completion of Unit S6 is assessed by the student in consultation with his adviser, who has observed some of the lessons in person or through recordings. If the initial practicum experience is not satisfying to the student, he has the opportunity (and may be so counselled) to undertake a second practicum experience at an appropriate time. More than anyone else, the student, who will be teaching science to elementary-school children, must be satisfied and feel confident about this culminating unit of the Science Knowledge System.

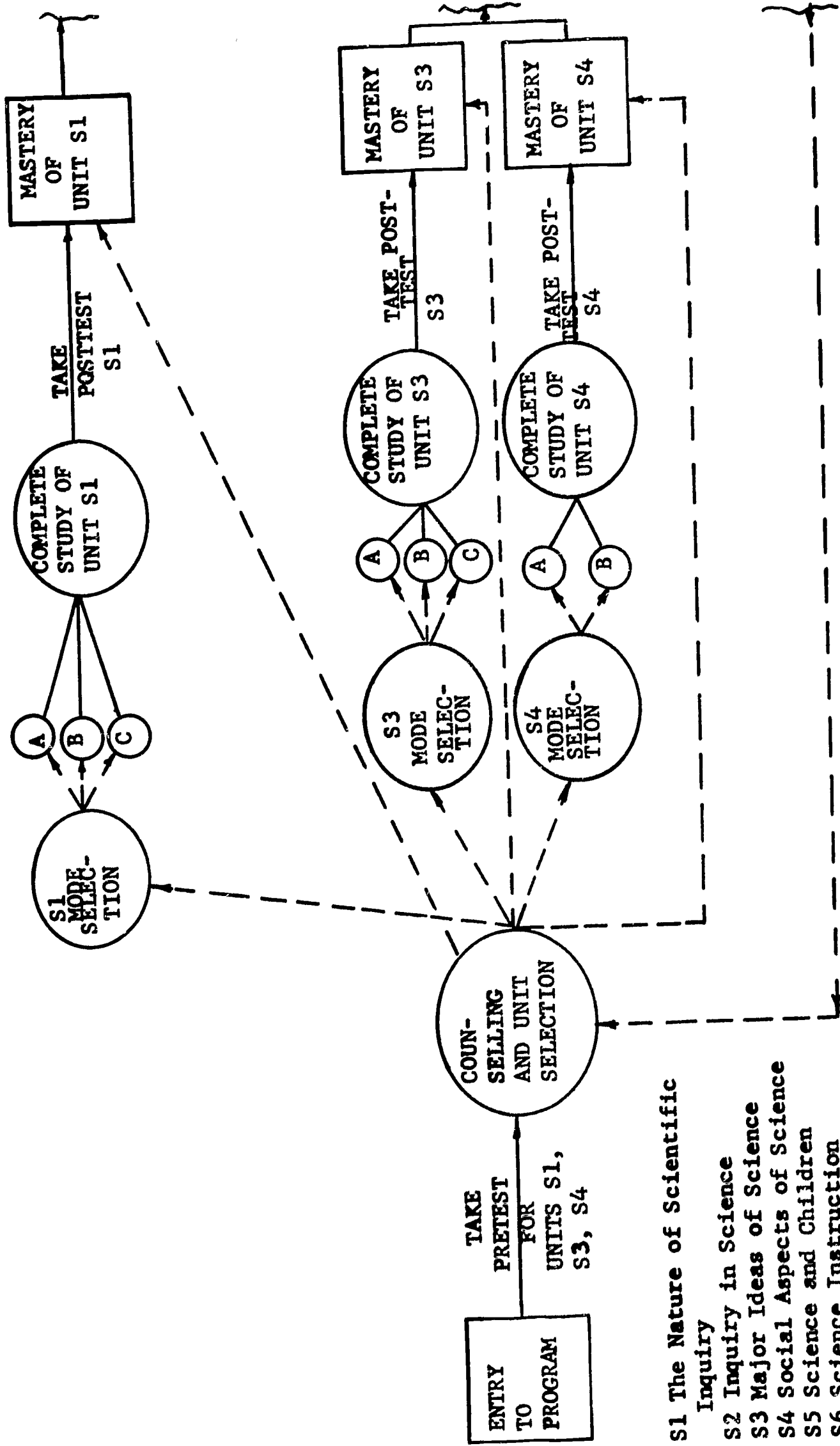

Unit S1 The Nature of Scientific Inquiry
 S2 Inquiry in Science
 S3 Major Ideas of Science
 S4 Social Aspects of Science
 S5 Science and Children
 S6 Science Instruction

Figure No. 29. Schematic for Science Module

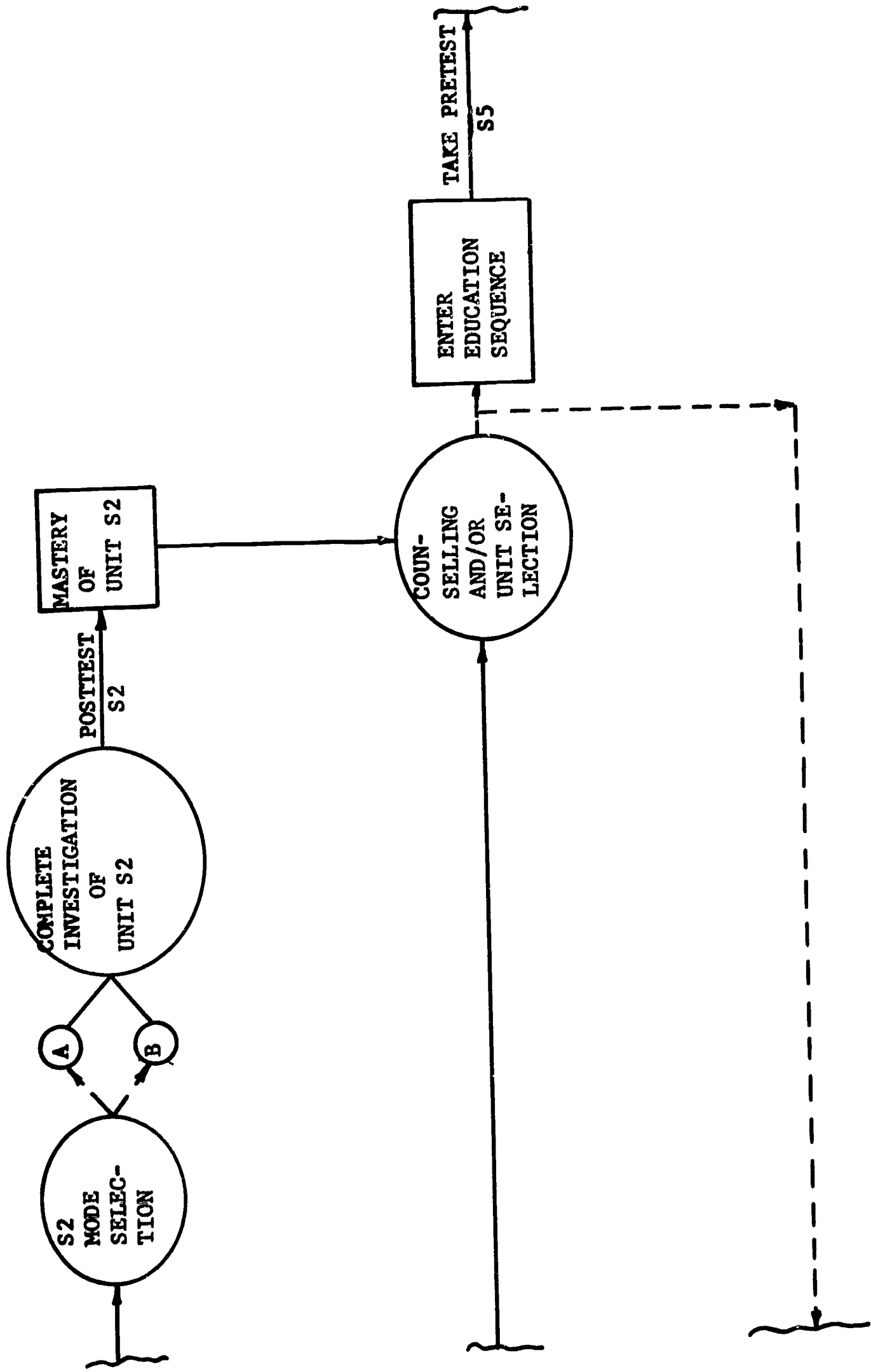
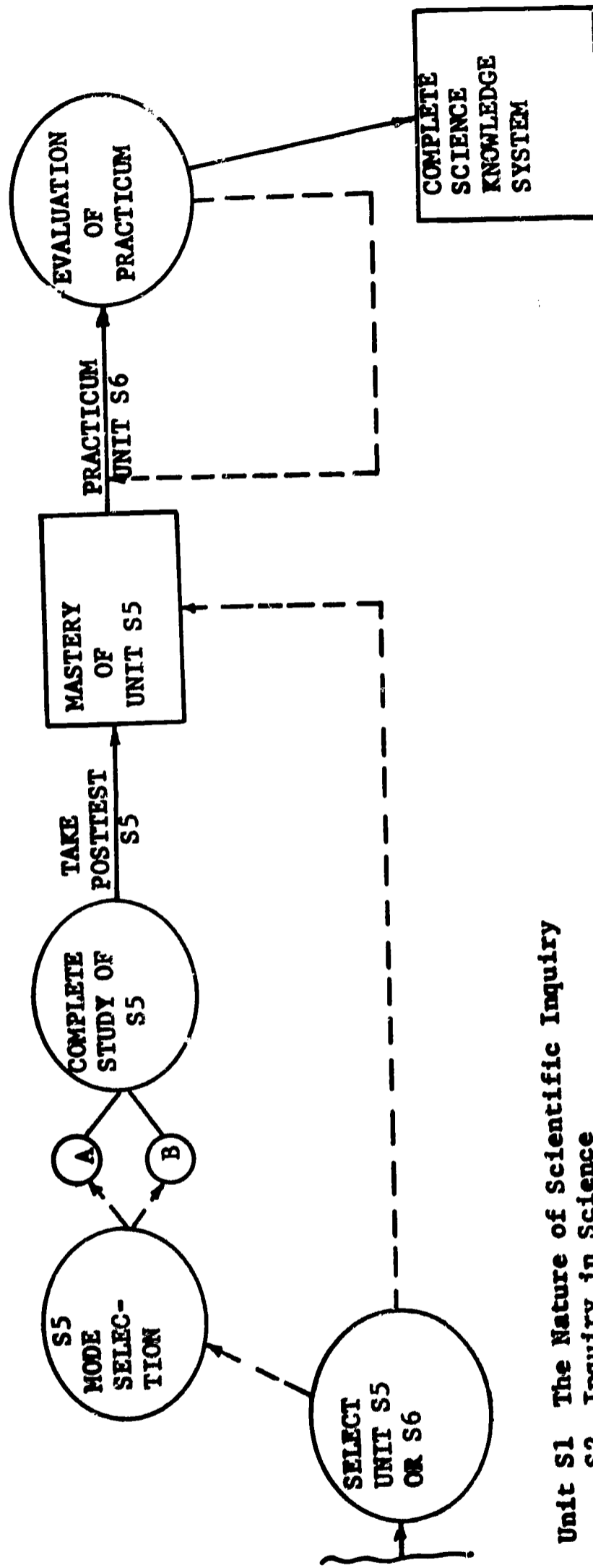

Figure No. 29. Schematic for Science Module



- Unit S1 The Nature of Scientific Inquiry
- S2 Inquiry in Science
- S3 Major Ideas of Science
- S4 Social Aspects of Science
- S5 Science and Children
- S6 Science Instruction

Figure No. 29. Schematic for Science Module

APPENDIX F
CONSULTANTS TO THE TEAM

THE MODEL DESIGN TEAM

ASSISTED BY

Dr. James S. Ackelson, Jr., Superintendent, Keystone Oaks
Dr. Wesley Becker, Consultant in Behavior Modification
Miss Joanne Benedict, Graduate Student, Elementary Education
Mr. Francis Benton, Mathematics Specialist
Dr. Jack Birch, Associate Dean, School of Education
Mr. David Bird, Lecturer, Elementary Education
Dr. Thomas Burkhart, Principal, Pittsburgh
Dr. Morris Cogan, Chairman, Teacher Education
Mr. William Cole, Graduate Student, Elementary Education
Dr. Shirley Davidson, Principal, Mt. Lebanon
Dr. Donald Deep, Principal, Baldwin-Whitehall
Dr. Donald M. Eichhorn, Assistant Superintendent, Upper St. Clair
Dr. William Engbretson, Professor, Higher Education, Temple University
Dr. Harry R. Faulk, Superintendent, McKeesport
Miss Grace Ferrero, Lecturer, Elementary Education
Mr. Joseph Fiori, Administrative Assistant, Elementary Education
Dr. Ernest B. Fleishman, Project Director, Pittsburgh
Mrs. Barbara Fredette, Lecturer, Art Education
Dr. Robert Glaser, Director, Learning Research & Development Center
Miss Mary Agnes Good, Lecturer, Elementary Education
Mrs. Theresa Gray, Mathematics Specialist
Miss Clair Halverson, Consultant in Individualizing Social Studies
Dr. J. Ernest Harrison, Assistant Superintendent, Baldwin-Whitehall
Miss Joan Jacobson, Consultant in Behavior Modification
Miss Betty Kapp, Secretary, Elementary Education
Mr. James Kelly, Administrative Assistant, School of Education
Dr. Leo Klopfer, Associate Professor, Elementary Education
Mr. Joseph Lachowicz, Consultant in Behavior Modification
Mrs. Celia B. Lerman, Secretary, Elementary Education
Mrs. Diane Ley, Mathematics Specialist
Dr. Paul Masoner, Dean, School of Education
Dr. James Mauch, Associate Professor, Education
Mrs. Sharyn Miller, Secretary, Elementary Education
Dr. Mary Molyneaux, Assistant Superintendent, Pittsburgh
Dr. J. William Moore, Professor of Education, Bucknell University
Mr. David O'Gorman, Media Assistant, Elementary Education
Dr. Kathleen O'Keefe, Research Associate, Learning Research & Development
Center
Dr. Herbert Olander, Professor, Elementary Education
Miss Violet Prescott, Secretary, Elementary Education
Dr. Lauren Resnick, Research Associate, Learning Research & Development
Center

Dr. Maxine Roberts, Professor, Elementary Education
Dr. James Schmunk, Assistant Superintendent, Churchill
Dr. Ralph Scott, Teacher Education Coordinator, Pittsburgh
Mrs. Dorothy Trachtenberg, Senior Secretary, Elementary Education
Dr. Margaret Wang, Research Associate, Learning Research & Development
Center
Mrs. Barbara Weihrauch, Consultant on Publications
Dr. John Yeager, Assistant Professor, Education